



refrigerating systems
EPTAGLOO

**INSTALLATION, USER
AND MAINTENANCE MANUAL**

READ CAREFULLY
AND KEEP WITH THE MACHINE

Number of document : **QSM000458E**

Revision status: F

Daye of 1st issue: **30.Jan.08**

Date of the present issue: 20.Dec.16



Epta

COSTAN TECHNICAL DOCUMENTATION		REVISION STATUS		TRUE COPY OF THE SIGNED ORIGINAL	PAGE 1 OF 1	
PRODUCT: EPTAGLOO			CHANGE ORDER		DATE OF 1st ISSUE	
DOC. no. QSM0000406A	CHAP. No.: 010	D	11.Nov.2010		SAFETY VALVE ADDED	13/June/07
CHAPTER: GENERAL INFORMATION/ TABLE OF CONTENTS		E	20/Nov/2012		NEW CHAPTER 020	ISSUED BY MKT

INSTALLATION, USE AND MAINTENANCE MANUAL

010 - GENERAL INFORMATION/TABLE OF CONTENTS

This manual has been compiled in a simple and easy-to-read manner so our units can be installed, set up and serviced correctly. **Please read its contents carefully and keep it near the machine at all times.**

The following points are of capital importance:

- The equipment must be installed, tested and serviced by skilled and legally qualified personnel.
- Local safety regulations applicable at the time of installation must be observed.
- The refrigerating equipment must only ever be used for the purpose for which it was designed. Uses other than those specified shall in no way be binding for the Manufacturer.
- Any packaging components included (plastic bags, polystyrene, wood, etc.) represent a potential hazard and must be kept out of the reach of children. Sort them out and dispose of them according to local applicable regulations.
- Power supply specifications must comply with the details shown on the serial plate of the machine.
- In the event of failure or malfunction, always switch off the machine.
- Modifications to the power system or unauthorized alterations in general, which are not contemplated in this manual, shall invalidate the warranty.
- To service or repair the machine, always contact an authorized Costan after-sales service centre and ask for original spare parts. Failure to do so could jeopardize machine and operator safety.

THE MANUFACTURER DISCLAIMS ALL LIABILITY FOR DIRECT OR INDIRECT DAMAGE TO PROPERTY AS WELL AS FOR ANY PERSONAL INJURY ARISING FROM FAILURE TO COMPLY WITH THE INSTRUCTIONS CONTAINED IN THIS MANUAL.

Table of contents

This manual consists of the following sections representing an integral part thereof and which must not be separated.

N.CHAP	CHAPTER	NUMBER OF PAGES:	REVISION STATUS
010	General information/table of contents	1	“ F “
020	Description / Technical details/Refrigerating diagrams	28	“F“
030	Handling and positioning	5	“ D “
040	Installation	20	“ D “
050	Electric panel technical specifications	7	“ A “
060	Wiring diagrams	1 + 15 ¹	“ - “
070	Control and regulation	1 + 25 ¹	“ A “
080	Outstanding risks	3	“ - “
090	Maintenance	4	“ C “

¹ The wiring diagrams and settings sheets attached are integral with the present manual and must be kept with this.

EPTA TECHNICAL DOCUMENTATION	REVISION STATUS			APPROVAL	PAGE 1 of 26
PRODUCT: EPTAGLOO	ORD	DATE		DTF.RD	DATE 1ST ISSUE
DOC. NO. QSM000406A CHAP.NO.:020	E	20/11/2012	UPDATES		13/06/2007
1\CHAPTER:DESCRIZIONE / DATI TECNICI	F	29/10/2014	BITZER NEWECOLINE and SF	DICON	MKT
	G	20/12/2016	UPDATE FOR R407F		

020 – DESCRIPTION/TECHNICAL SPECIFICATIONS

General information

Eptagloo packs are available in versions with three or four semi-hermetic Bitzer compressors (Octagon series), connected in parallel; they are suitable for medium temperature applications with R404A/R407F for installation in special technical rooms (plant rooms) or outdoor with enclosure for protection against the weather.

The range, designed and built in compliance with current regulations and European Directives, is offered in a basic version, for installation indoors, including only the components that are strictly necessary to ensure total reliability and efficiency of the machine to Epta's quality standards: electrical control and compressor adjustment panel, compressors installed on a sturdy frame with painted galvanized sheet metal profiles, suction manifold designed to ensure oil return to the compressors, intake filter, filter dryer on liquid line with passage indicator and humidity indicator, liquid receiver. The high degree of customization starts with the option, even in the basic version, of no less than five different types of electronic controllers and a power supply electrical panel that can feature magneto-thermal switch protection or magneto-thermal with differentials. The type of installation (indoor, in plant rooms, or outdoor) can be combined with an enclosure with soundproofing material. The accessories range from inspectable oil separator with direct discharge on aspiration to complete oil return system with inspectable separator, oil reserve, distribution header and float-type controllers. Other features are mufflers on each compressor, external pressure inlets, glycerine-filled high and low pressure gauges, compressor power-factor correction, liquid subcooling for low temperature packs (in combination with a medium temperature pack).

MAIN FEATURES (STANDARD VERSION)

- Electrical power supply panel constructed to CEI EN 60204-1, on board the equipment and pre-wired. The panel undergoes functional testing at the factory before the machine is released. External master circuitbreaking handle.
- Removable controller module box with external access door. Possibility of choosing between five different types of controllers.
- Suction header with anti-liquid function, insulation of all suction, of suction sections in the circuit (header - compressor) and of suction filters.
- Replaceable mechanical cartridge filter on the suction line upstream of the suction header (two filters for four-compressor packs).
- On-board liquid receiver vessel, pursuant to Directive 97/23 CE with 40 L (3 compressors) and 60 L (4 compressors) capacity
- Safety valve complying with Directive 97/23/CE for protection of liquid receiver against pressure buildup due to external heat sources (fire).
- Replaceable high-capacity anti-acid filter dryer cartridge on the liquid line, with liquid and moisture sight glass.
- Pressure switch panel and sensors including:
 - two high-pressure switches (system safety with manual reset) for protection against pressure buildup due to operation error or other cause. When test-run as per operational instruction QOP019110A, correct tripping of safety pressure-switches is simulated and verified.
 - a high pressure switch per compressor (compressor safety)
 - a low pressure switch for compressor/system safety
 - a backup low pressure switch
 - a backup high pressure switch (only with high-pressure control electronics)
 - three or four high-pressure switches for condenser fan control (only with low-pressure control electronics)
 - low-pressure transducer (probe) and, depending on controller type, high-pressure transducer
- "CIC" liquid injection system installed on low-temperature packs with R407F refrigerant.

EPTA TECHNICAL DOCUMENTATION	REVISION STATUS			APPROVAL	PAGE 2 of 26
PRODUCT: EPTAGLOO	ORD	DATE		DTF.RD	DATE 1ST ISSUE
DOC. NO. QSM000406A CHAP.NO.:020	E	20/11/2012	UPDATES		13/06/2007
1\CHAPTER:DESCRIZIONE / DATI TECNICI	F	29/10/2014	BITZER NEWECOLINE and SF	DICON	MKT
	G	20/12/2016	UPDATE FOR R407F		

Accessories

Enclosure for indoor installations, with soundproofing (enclosure lined with externally-embossed, double-layer polyurethane foam sheets and bituminous coating). Easy-to-remove panels with 90° securing tabs and fall-proof pins.

Enclosure suitable for outdoor installations, with soundproofing (enclosure lined with externally-embossed, double-layer polyurethane foam sheets and bituminous coating). Easy-to-remove panels with 90° securing tabs and fall-proof pins. Constructed to guarantee IP44 degree of protection.

Forced internal ventilation by helical extracting fan; fan on-off control by electric thermostat with programmable set point. Temperature probe in compressor compartment.

External ¼" SAE HP and LP pressure inlets

External high and low pressure glycerine-filled gauges

Inspectable oil separator with direct discharge on aspiration

Complete oil return system (inspectable separator, reserve, header and float-type controllers).

Optical liquid-level sensor on the receiver vessel.

Discharge muffler (one per compressor).

Compressor power-factor correction.

Liquid subcooling in low-temperature pack.

Wood packaging with HT treatment certification.

COSTAN TECHNICAL DOCUMENTATION		REVISION STATUS		TRUE COPY		PAGE 3 OF 28	
PRODUCT: 020 – DESCRIPTION / TECHNICAL DETAILS		CHANGE ORDER		OF THE SIGNED		DATE OF 1st ISSUE	
DOC. no. QSM0000406A	CHAP. No.: 020	B	28/July/2009	SF UPDATED - NC ADDED	ORIGINAL		
CHAPTER: DESCRIPTION / TECHNICAL DETAILS		C	23/Feb/2010	RANGE EXTENSION			
		D	11/Nov/2010	SAFETY VALVE ADDED			
		E	20/Nov/2012	UPDATE			
					ISSUED BY MKT		

Dimensional diagrams – Systems with three-compressor systems

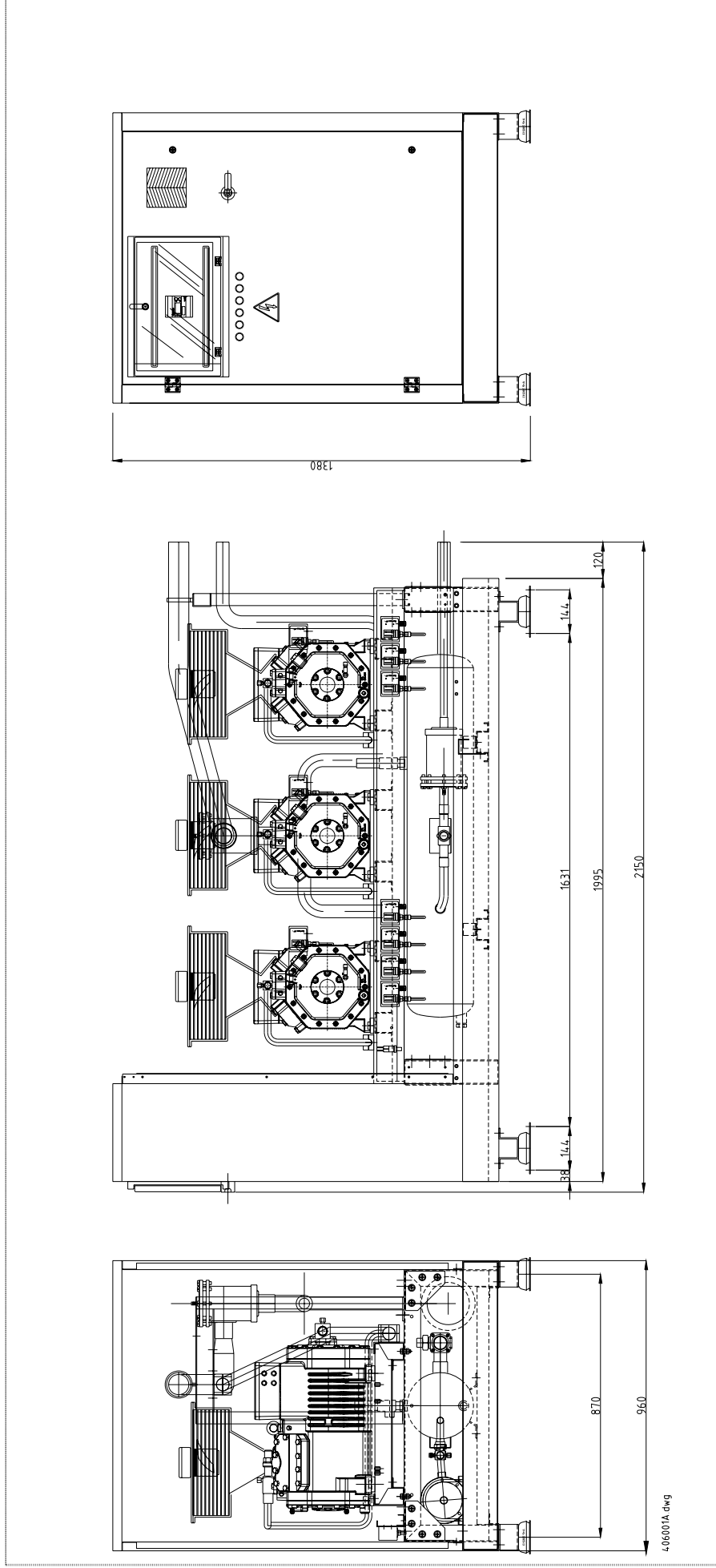

COSTAN TECHNICAL DOCUMENTATION		REVISION STATUS		TRUE COPY		PAGE 4 OF 28	
PRODUCT: 020 - DESCRIPTION / TECHNICAL DETAILS		CHANGE ORDER		OF THE SIGNED		DATE OF 1st ISSUE	
DOC. no. QSM0000406A	CHAP. No.: 020	B	28/July/2009	SF UPDATED - NC ADDED	ORIGINAL	13/June/07	
CHAPTER: DESCRIPTION / TECHNICAL DETAILS		C	23/Feb/2010	RANGE EXTENSION		ISSUED BY MKT	
		D	11/Nov/2010	SAFETY VALVE ADDED			
		E	20/Nov/2012	UPDATE			

Dimensional diagrams – Systems with three-compressors and enclosure

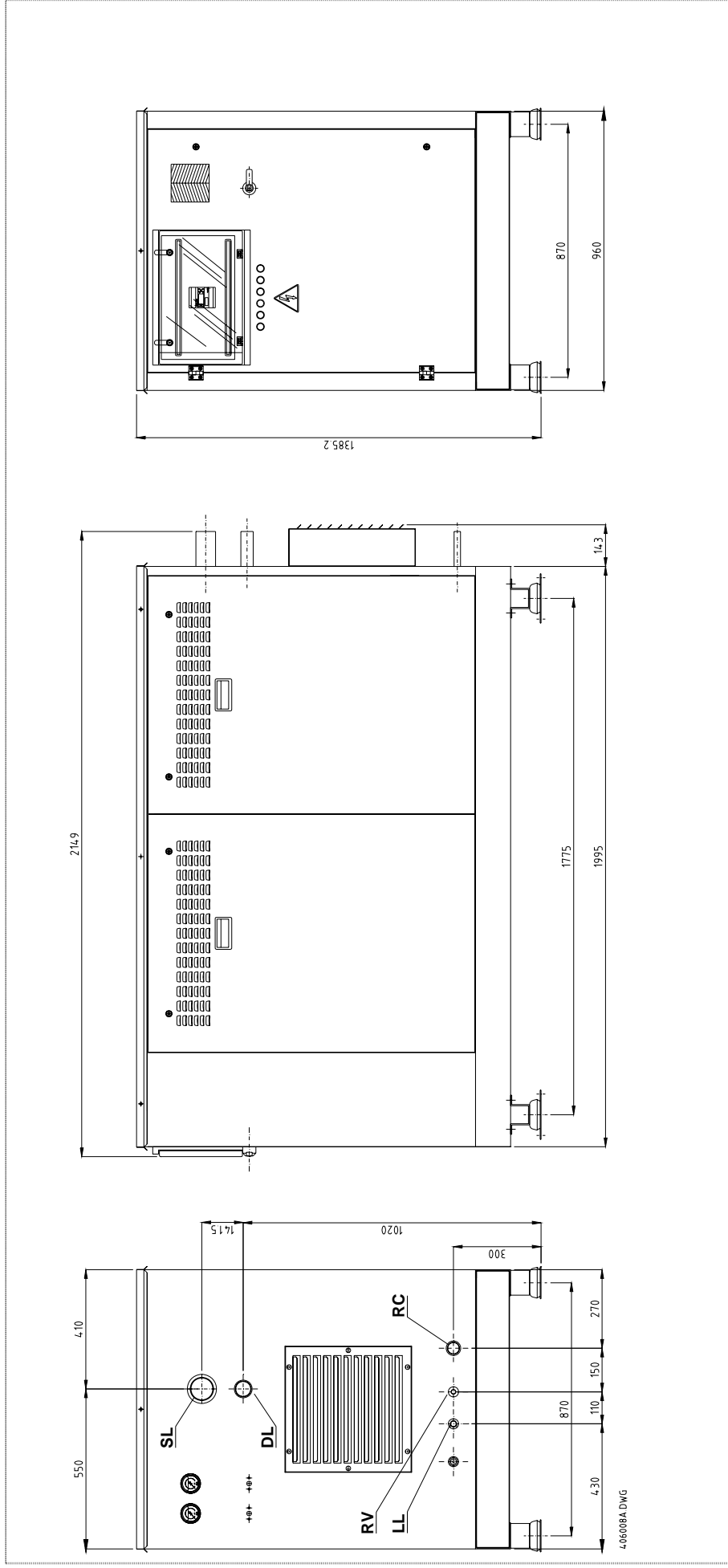

Note: the position of system-connecting pipework is the same for both versions. The air-exPELLing fan on the right side is featured as an optional extra.

COSTAN TECHNICAL DOCUMENTATION		REVISION STATUS		TRUE COPY		PAGE 5 OF 28	
PRODUCT: 020 - DESCRIPTION / TECHNICAL DETAILS		CHANGE ORDER		OF THE SIGNED		DATE OF 1st ISSUE	
DOC. no. QSM0000406A	CHAP. No.: 020	B	28/July/2009	SF UPDATED - NC ADDED	ORIGINAL		
CHAPTER: DESCRIPTION / TECHNICAL DETAILS		C	23/Feb/2010	RANGE EXTENSION	ISSUED BY MKT		
		D	11/Nov/2010	SAFETY VALVE ADDED			
		E	20/Nov/2012	UPDATE			

Dimensional diagrams – Systems with four-compressors

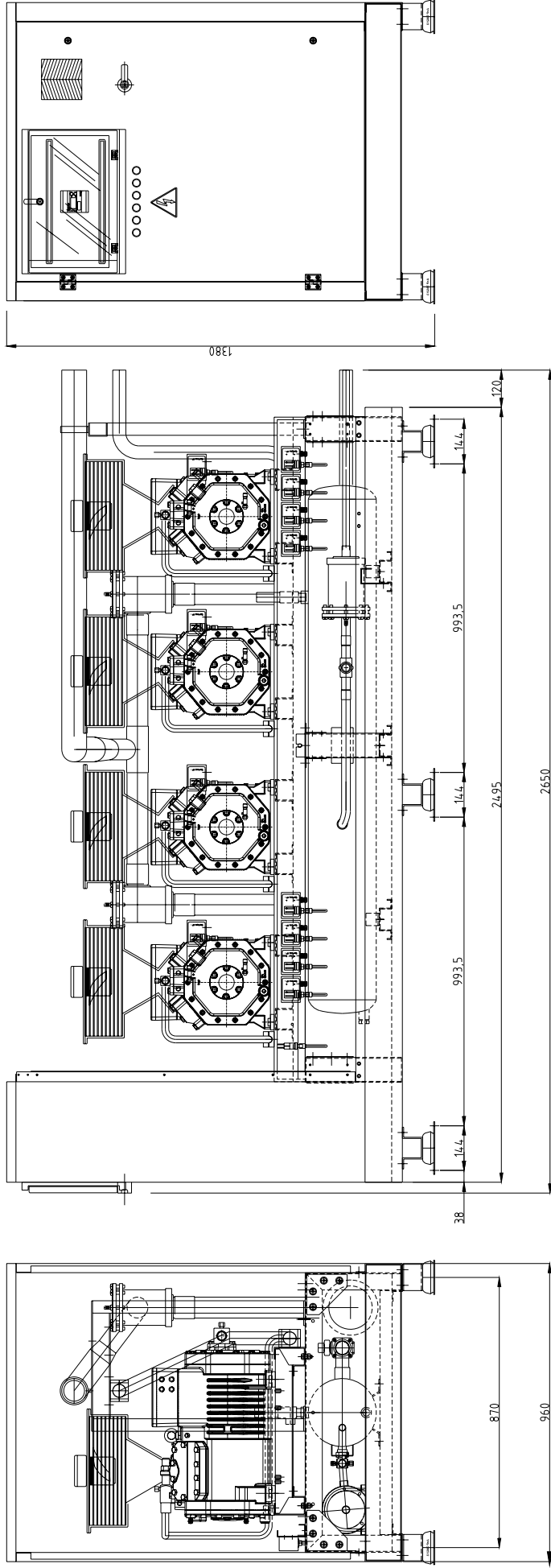

4.06002A.dwg

COSTAN TECHNICAL DOCUMENTATION		REVISION STATUS		TRUE COPY		PAGE 6 OF 28	
PRODUCT: 020 - DESCRIPTION / TECHNICAL DETAILS		CHANGE ORDER		OF THE SIGNED		DATE OF 1st ISSUE	
DOC. no. QSM0000406A	CHAP. No.: 020	B	28/July/2009	SF UPDATED - NC ADDED	ORIGINAL		
CHAPTER: DESCRIPTION / TECHNICAL DETAILS		C	23/Feb/2010	RANGE EXTENSION	ISSUED BY MKT		
		D	11/Nov/2010	SAFETY VALVE ADDED			
		E	20/Nov/2012	UPDATE			

Dimensional diagrams – Systems with four-compressor and enclosure

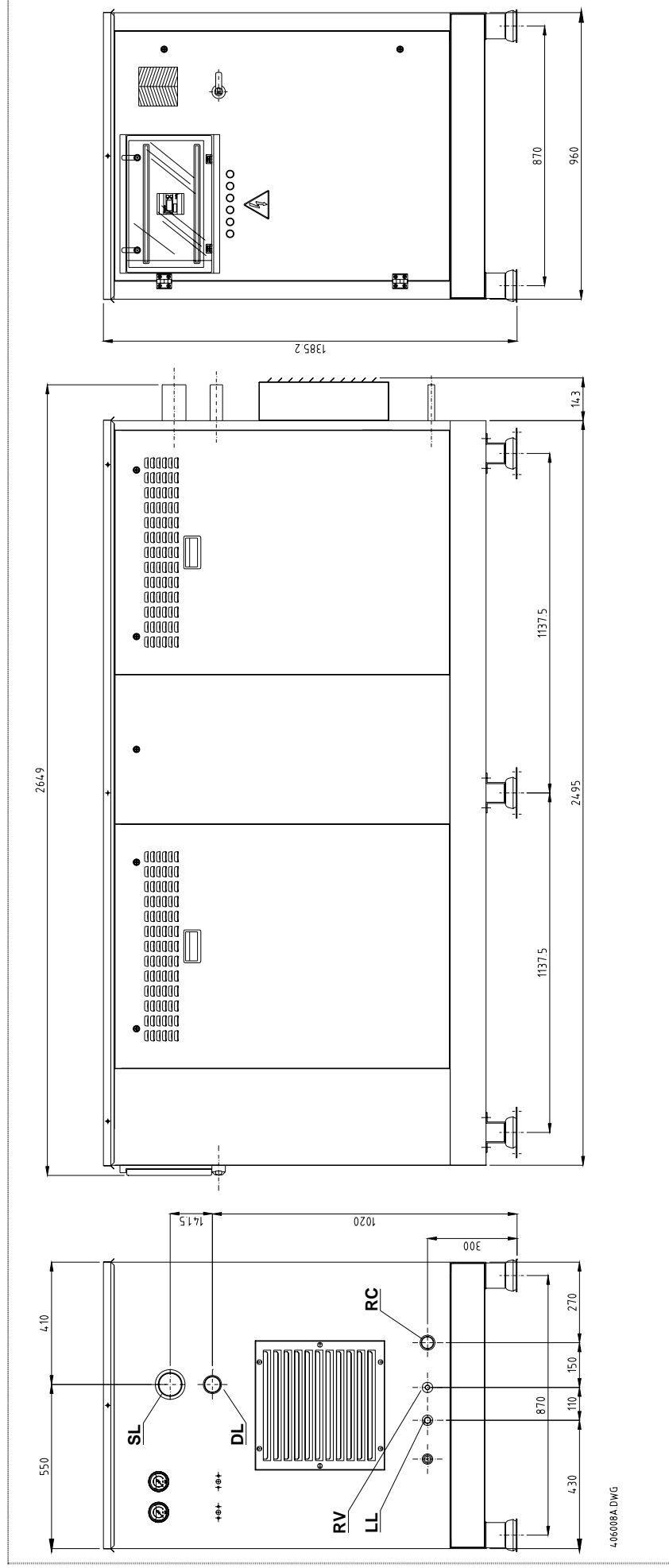

Note: the position of system-connecting pipework is the same for both versions. The air-expelling fan on the right hand side is featured as an optional extra.

EPTA TECHNICAL DOCUMENTATION PRODUCT: EPTAGLOO DOC. NO. QSM000406A CHAP.NO.:020 1\CHAPTER:DESCRIZIONE / DATI TECNICI	REVISION STATUS			APPROVAL	PAGE 11 of 26
	ORD	DATE		DTF.RD	DATE 1ST ISSUE
	E	20/11/2012	UPDATES		13/06/2007
	F	29/10/2014	BITZER NEWECOLINE and SF	DICON	MKT
G	20/12/2016	UPDATE FOR R407F			

Medium temperature applications (R404A) – 3 Bitzer compressors

TABLE 1A

Pack model	3 x 2EES-2Y	3 x 2DES-2Y	3 x 2CES-3Y
Supply voltage	400 / 3 / 50	400 / 3 / 50	400 / 3 / 50
N° of compressors	3	3	3
Refrigerant	R404A	R404A	R404A
Cooling capacity ¹ (W)	18900	22620	27930
Absorbed power ¹ (W)	7650	8820	10740
Maximum absorption ² (A)	18	22.5	27.3

Pipework			
Discharge pipe diameter (mm)	22	28	28
Return pipe diameter (mm)	22	22	28
Suction diameter (mm)	42	42	42

Dimensions and weight ³			
Length (mm) excluding exhaust fan	1995	1995	1995
Width (mm)	960	960	960
Height (mm)	1380	1380	1380
Weight (Kg)	691	692	699

Compressor	2EES-2Y	2DES-2Y	2CES-3Y
Type	Semi-hermetic reciprocating	Semi-hermetic reciprocating	Semi-hermetic reciprocating
Brand	Bitzer	Bitzer	Bitzer
Series	Octagon	Octagon	Octagon
Lubricant Bitzer	BSE 32	BSE 32	BSE 32
Absorb. during op'n ¹ (A)	4.38	5.23	6.59
Maximum Absorption ² (A)	6	7.5	9.1

Receiver			
Liquid receiver volume (L)	40	40	40
Liquid diameter (inlet/outlet) (mm)	22	22	22

Electrical board (400/3/50)			
Code e.b. with MT	UQ391AM6E	UQ391AM7E	UQ391AM8E
Code e.b. with MTD	UQ391AD6E	UQ391AD7E	UQ391AD8E
Magneto-thermal protection range - compr.	(4.5 – 6.3)A	(5.5 - 8)A	(7 – 10)A

Carel controller	IR33Z9HR20	IR33Z9HR20	IR33Z9HR20
Danfoss controller	EKC331/T	EKC331/T	EKC331/T
Carel controller	PCO3	PCO3	PCO3
Danfoss controller	AK-PC530	AK-PC530	AK-PC530
Carel controller	mRACK	mRACK	mRACK
Dixell controller	XC1015D	XC1015D	XC1015D

¹ Data calculated with Bitzer software at Te=-10°C ; Tc=+40°C ; Temp. of aspirated gas =20°C ;subcooling of 0°K liquid (pursuant to directive EN12900).

Value for absorbed power does not include condenser fans, the optional one installed on the casing and it refers to the absorption of the compressors without power-factor correction capacitors.

² Bitzer compressors specifications as per software

³ The data shown in the table refer to the enclosed version with full oil circuit

EPTA TECHNICAL DOCUMENTATION PRODUCT: EPTAGLOO DOC. NO. QSM000406A CHAP.NO.:020 1\CHAPTER:DESCRIZIONE / DATI TECNICI	REVISION STATUS			APPROVAL	PAGE 12 of 26
	ORD	DATE		DTF.RD	DATE 1ST ISSUE
	E	20/11/2012	UPDATES		13/06/2007
	F	29/10/2014	BITZER NEWECOLINE and SF	DICON	MKT
G	20/12/2016	UPDATE FOR R407F			

Medium temperature applications (R404A) – 3 Bitzer compressors

TABLE 2A

Pack model	3 x 4FES-3Y	3 x 4EES-4Y	3 x 4DES-5Y
Supply voltage	400 / 3 / 50	400 / 3 / 50	400 / 3 / 50
N° of compressors	3	3	3
Refrigerant	R404A	R404A	R404A
Cooling capacity ¹ (W)	30120	38220	45570
Absorbed power ¹ (W)	12300	14800	17850
Maximum absorption ² (A)	28.5	36.6	43.5

Pipework			
Discharge pipe diameter (mm)	28	35	35
Return pipe diameter (mm)	28	35	35
Suction diameter (mm)	42	54	54

Dimensions and weight ³			
Length (mm) excluding exhaust fan	1995	1995	1995
Width (mm)	960	960	960
Height (mm)	1380	1380	1380
Weight (Kg)	735	742	756

Compressor	4FES-3Y	4EES-4Y	4DES-5Y
Type	Semi-hermetic reciprocating	Semi-hermetic reciprocating	Semi-hermetic reciprocating
Brand	Bitzer	Bitzer	Bitzer
Series	Octagon	Octagon	Octagon
Lubricant Bitzer	BSE 32	BSE 32	BSE 32
Absorb. during op'n ¹ (A)	7.12	8.56	10.3
Maximum Absorption ² (A)	9.5	12.2	14.5

Receiver			
Liquid receiver volume (L)	40	40	40
Liquid diameter (inlet/outlet) (mm)	22	22	22

Electrical board (400/3/50)			
Code e.b. with MT	UQ391AM8E	UQ391AMAE	UQ391AM8E
Code e.b. with MTD	UQ391AD8E	UQ391ADAE	UQ391AD8E
Magneto-thermal protection range - compr.	(7 - 10)A	(11 - 16)A	(11 - 16)A

Carel controller	IR33Z9HR20	IR33Z9HR20	IR33Z9HR20
Danfoss controller	EKC331/T	EKC331/T	EKC331/T
Carel controller	PCO3	PCO3	PCO3
Danfoss controller	AK-PC530	AK-PC530	AK-PC530
Carel controller	mRACK	mRACK	mRACK
Dixell controller	XC1015D	XC1015D	XC1015D

¹ Data calculated with Bitzer software at Te=-10°C ; Tc=+40°C ; Temp. of aspirated gas =20°C ;subcooling of 0°K liquid (pursuant to directive EN12900).

Value for absorbed power does not include condenser fans, the optional one installed on the casing and it refers to the absorption of the compressors without power-factor correction capacitors.

² Bitzer compressors specifications as per software

³ The data shown in the table refer to the enclosed version with full oil circuit

EPTA TECHNICAL DOCUMENTATION PRODUCT: EPTAGLOO DOC. NO. QSM000406A CHAP.NO.:020 1\CHAPTER:DESCRIZIONE / DATI TECNICI	REVISION STATUS		APPROVAL	PAGE 13 of 26
	ORD	DATE	DTF.RD	DATE 1ST ISSUE
	E	20/11/2012		UPDATES
	F	29/10/2014	BITZER NEWECOLINE and SF	MKT
G	20/12/2016	UPDATE FOR R407F		

Medium temperature applications (R404A) – 3 Bitzer compressors

TABLE 3A

Pack model	3 x 4CES-6Y	3 x 4VES-7Y	3 x 4TES-9Y
Supply voltage	400 / 3 / 50	400 / 3 / 50	400 / 3 / 50
N° of compressors	3	3	3
Refrigerant	R404A	R404A	R404A
Cooling capacity ¹ (W)	55050	57150	69600
Absorbed power ¹ (W)	21500	22350	27200
Maximum absorption ² (A)	53.1	49.8	59.7

Pipework			
Discharge pipe diameter (mm)	35	35	42
Return pipe diameter (mm)	35	35	42
Suction diameter (mm)	54	54	66

Dimensions and weight ³			
Length (mm) excluding exhaust fan	1995	1995	1995
Width (mm)	960	960	960
Height (mm)	1380	1380	1380
Weight (Kg)	771	889	904

Compressor	4CES-6Y	4VES-7Y	4TES-9Y
Type	Semi-hermetic reciprocating	Semi-hermetic reciprocating	Semi-hermetic reciprocating
Brand	Bitzer	Bitzer	Bitzer
Series	Octagon	Octagon	Octagon
Lubricant Bitzer	BSE 32	BSE 32	BSE 32
Absorb. during op'n ¹ (A)	12.42	12.35	15.1
Maximum Absorption ² (A)	17.7	16.6	19.9

Receiver			
Liquid receiver volume (L)	40	40	40
Liquid diameter (inlet/outlet) (mm)	22	22	22

Electrical board (400/3/50)			
Code e.b. with MT	UQ391AMBE	UQ391AMBE	UQ391AMBE
Code e.b. with MTD	UQ391ADBE	UQ391ADBE	UQ391ADBE
Magneto-thermal protection range - compr.	(14 – 20)A	(14 – 20)A	(14 – 20)A

Carel controller	IR33Z9HR20	IR33Z9HR20	IR33Z9HR20
Danfoss controller	EKC331/T	EKC331/T	EKC331/T
Carel controller	PCO3	PCO3	PCO3
Danfoss controller	AK-PC530	AK-PC530	AK-PC530
Carel controller	mRACK	mRACK	mRACK
Dixell controller	XC1015D	XC1015D	XC1015D

¹ Data calculated with Bitzer software at Te=-10°C ; Tc=+40°C ; Temp. of aspirated gas =20°C ;subcooling of 0°K liquid (pursuant to directive EN12900).

Value for absorbed power does not include condenser fans, the optional one installed on the casing and it refers to the absorption of the compressors without power-factor correction capacitors.

² Bitzer compressors specifications as per software

³ The data shown in the table refer to the enclosed version with full oil circuit

EPTA TECHNICAL DOCUMENTATION PRODUCT: EPTAGLOO DOC. NO. QSM000406A CHAP.NO.:020 1\CHAPTER:DESCRIZIONE / DATI TECNICI	REVISION STATUS		APPROVAL	PAGE 14 of 26
	ORD	DATE	DTF.RD	DATE 1ST ISSUE
	E	20/11/2012		13/06/2007
	F	29/10/2014	DICON	MKT
G	20/12/2016	UPDATE FOR R407F		

Medium temperature applications (R404A) – 3 Bitzer compressors

TABLE 4A

Pack model	3 x 4PES-12Y	3 x 4NES-14Y
Supply voltage	400 / 3 / 50	400 / 3 / 50
N° of compressors	3	3
Refrigerant	R404A	R404A
Cooling capacity ¹ (W)	79500	94800
Absorbed power ¹ (W)	29550	35790
Maximum absorption ² (A)	68.1	79.8

Pipework		
Discharge pipe diameter (mm)	42	42
Return pipe diameter (mm)	42	42
Suction diameter (mm)	66	66

Dimensions and weight ³		
Length (mm) excluding exhaust fan	1995	1995
Width (mm)	960	960
Height (mm)	1380	1380
Weight (Kg)	919	925

Compressor	4PES-12Y	4NES-14Y
Type	Semi-hermetic reciprocating	Semi-hermetic reciprocating
Brand	Bitzer	Bitzer
Series	Octagon	Octagon
Lubricant Bitzer	BSE 32	BSE 32
Absorb. during op'n ¹ (A)	17.01	20.2
Maximum Absorption ² (A)	22.7	26.6

Receiver		
Liquid receiver volume (L)	40	40
Liquid diameter (inlet/outlet) (mm)	22	22

Electrical board (400/3/50)		
Code e.b. with MT	UQ391AMCE	UQ391AMDE
Code e.b. with MTD	UQ391ADCE	UQ391ADDE
Magneto-thermal protection range - compr.	(20 - 25)A	(22 – 32)A

Carel controller	IR33Z9HR20	IR33Z9HR20
Danfoss controller	EKC331/T	EKC331/T
Carel controller	PCO3	PCO3
Danfoss controller	AK-PC530	AK-PC530
Carel controller	mRACK	mRACK
Dixell controller	XC1015D	XC1015D

¹ Data calculated with Bitzer software at Te=-10°C ; Tc=+40°C ; Temp. of aspirated gas =20°C ;subcooling of 0°K liquid (pursuant to directive EN12900).

Value for absorbed power does not include condenser fans, the optional one installed on the casing and it refers to the absorption of the compressors without power-factor correction capacitors.

² Bitzer compressors specifications as per software

³ The data shown in the table refer to the enclosed version with full oil circuit

EPTA TECHNICAL DOCUMENTATION PRODUCT: EPTAGLOO DOC. NO. QSM000406A CHAP.NO.:020 1\CHAPTER:DESCRIZIONE / DATI TECNICI	REVISION STATUS			APPROVAL	PAGE 15 of 26
	ORD	DATE		DTF.RD	DATE 1ST ISSUE
	E	20/11/2012	UPDATES		13/06/2007
	F	29/10/2014	BITZER NEWECOLINE and SF	DICON	MKT
G	20/12/2016	UPDATE FOR R407F			

Low temperature applications (R404A) – 3 Bitzer compressors

TABLE 5A

Pack model	3 x 4FES-3Y	3 x 4EES-4Y	3 x 4DES-5Y
Supply voltage	400 / 3 / 50	400 / 3 / 50	400 / 3 / 50
N° of compressors	3	3	3
Refrigerant	R404A	R404A	R404A
Cooling capacity ¹ (W)	9090	11490	13740
Absorbed power ¹ (W)	6720	8310	9900
Maximum absorption ² (A)	28.5	36.6	43.5

Pipework			
Discharge pipe diameter (mm)	16	22	22
Return pipe diameter (mm)	22	22	22
Suction diameter (mm)	42	54	54

Dimensions and weight ³			
Length (mm) excluding exhaust fan	1995	1995	1995
Width (mm)	960	960	960
Height (mm)	1380	1380	1380
Weight (Kg)	734	741	745

Compressor	4FES-3Y	4EES-4Y	4DES-5Y
Type	Semi-hermetic reciprocating	Semi-hermetic reciprocating	Semi-hermetic reciprocating
Brand	Bitzer	Bitzer	Bitzer
Series	Octagon	Octagon	Octagon
Lubricant Bitzer	BSE 32	BSE 32	BSE 32
Absorb. during op'n ¹ (A)	4.98	5.31	6.69
Maximum Absorption ² (A)	9.5	12.2	14.5

Receiver			
Liquid receiver volume (L)	40	40	40
Liquid diameter (inlet/outlet) (mm)	22	22	22

Electrical board (400/3/50)			
Code e.b. with MT	UQ391AM8E	UQ391AMAE	UQ391AMAE
Code e.b. with MTD	UQ391AD8E	UQ391ADAE	UQ391ADAE
Magneto-thermal protection range - compr.	(7 – 10)A	(11 – 16)A	(11 – 16)A

Carel controller	IR33Z9HR20	IR33Z9HR20	IR33Z9HR20
Danfoss controller	EKC331/T	EKC331/T	EKC331/T
Carel controller	PCO3	PCO3	PCO3
Danfoss controller	AK-PC530	AK-PC530	AK-PC530
Carel controller	mRACK	mRACK	mRACK
Dixell controller	XC1015D	XC1015D	XC1015D

¹ Data calculated with Bitzer software at Te=-35°C ; Tc=+40°C ; Temp. of aspirated gas =20°C ;subcooling of 0°K liquid (pursuant to directive EN12900).

Value for absorbed power does not include condenser fans, the optional one installed on the casing and it refers to the absorption of the compressors without power-factor correction capacitors.

² Bitzer compressors specifications as per software

³ The data shown in the table refer to the enclosed version with full oil circuit

EPTA TECHNICAL DOCUMENTATION PRODUCT: EPTAGLOO DOC. NO. QSM000406A CHAP.NO.:020 1\CHAPTER:DESCRIZIONE / DATI TECNICI	REVISION STATUS			APPROVAL	PAGE 16 of 26
	ORD	DATE		DTF.RD	DATE 1ST ISSUE
	E	20/11/2012	UPDATES		13/06/2007
	F	29/10/2014	BITZER NEWECOLINE and SF	DICON	MKT
G	20/12/2016	UPDATE FOR R407F			

Low temperature applications (R404A) – 3 Bitzer compressors

TABLE 6A

Pack model	3 x 4CES-6Y	3 x 4TES-9Y
Supply voltage	400 / 3 / 50	400 / 3 / 50
N° of compressors	3	3
Refrigerant	R404A	R404A
Cooling capacity ¹ (W)	16200	19440
Absorbed power ¹ (W)	11820	13980
Maximum absorption ² (A)	53.1	59.7
Pipework		
Discharge pipe diameter (mm)	28	28
Return pipe diameter (mm)	28	28
Suction diameter (mm)	66	66
Dimensions and weight³		
Length (mm) excluding exhaust fan	1995	1995
Width (mm)	960	960
Height (mm)	1380	1380
Weight (Kg)	761	891
Compressor		
Type	4CES-6Y Semi-hermetic reciprocating	4TES-9Y Semi-hermetic reciprocating
Brand	Bitzer	Bitzer
Series	Octagon	Octagon
Lubricant Bitzer	BSE 32	BSE 32
Absorb. during op'n ¹ (A)	8.19	8.66
Maximum Absorption ² (A)	17.7	19.9
Receiver		
Liquid receiver volume (L)	40	40
Liquid diameter (inlet/outlet) (mm)	22	22
Electrical board (400/3/50)		
Code e.b. with MT	UQ391AMBE	UQ391AMBE
Code e.b. with MTD	UQ391ADBE	UQ391ADBE
Magneto-thermal protection range - compr.	(14 – 20)A	(14 – 20)A
Carel controller	IR33Z9HR20	IR33Z9HR20
Danfoss controller	EKC331/T	EKC331/T
Carel controller	PCO3	PCO3
Danfoss controller	AK-PC530	AK-PC530
Carel controller	mRACK	mRACK
Dixell controller	XC1015D	XC1015D

¹ Data calculated with Bitzer software at Te=-35°C ; Tc=+40°C ; Temp. of aspirated gas =20°C ;subcooling of 0°K liquid (pursuant to directive EN12900).

Value for absorbed power does not include condenser fans, the optional one installed on the casing and it refers to the absorption of the compressors without power-factor correction capacitors.

² Bitzer compressors specifications as per software

³ The data shown in the table refer to the enclosed version with full oil circuit

EPTA TECHNICAL DOCUMENTATION PRODUCT: EPTAGLOO DOC. NO. QSM000406A CHAP.NO.:020 1\CHAPTER:DESCRIZIONE / DATI TECNICI	REVISION STATUS			APPROVAL	PAGE 17 of 26
	ORD	DATE		DTF.RD	DATE 1ST ISSUE
	E	20/11/2012	UPDATES		13/06/2007
	F	29/10/2014	BITZER NEWECOLINE and SF	DICON	MKT
G	20/12/2016	UPDATE FOR R407F			

Low temperature applications (R404A) – 3 Bitzer compressors

TABLE 7A

Pack model	3 x 4PES-12Y	3 x 4NES-14Y
Supply voltage	400 / 3 / 50	400 / 3 / 50
N° of compressors	3	3
Refrigerant	R404A	R404A
Cooling capacity ¹ (W)	20940	26460
Absorbed power ¹ (W)	15900	18570
Maximum absorption ² (A)	68.1	79.8

Pipework		
Discharge pipe diameter (mm)	28	42
Return pipe diameter (mm)	28	42
Suction diameter (mm)	66	66

Dimensions and weight ³		
Length (mm) excluding exhaust fan	1995	1995
Width (mm)	960	960
Height (mm)	1380	1380
Weight (Kg)	907	923

Compressor	4PES-12Y	4NES-14Y
Type	Semi-hermetic reciprocating	Semi-hermetic reciprocating
Brand	Bitzer	Bitzer
Series	Octagon	Octagon
Lubricant Bitzer	BSE 32	BSE 32
Absorb. during op'n ¹ (A)	9.88	11.71
Maximum Absorption ² (A)	22.7	26.6

Receiver		
Liquid receiver volume (L)	40	40
Liquid diameter (inlet/outlet) (mm)	22	22

Electrical board (400/3/50)		
Code e.b. with MT	UQ391AMCE	UQ391AMDE
Code e.b. with MTD	UQ391ADCE	UQ391ADDE
Magneto-thermal protection range - compr.	(20 – 25)A	(22 – 32)A

Carel controller	IR33Z9HR20	IR33Z9HR20
Danfoss controller	EKC331/T	EKC331/T
Carel controller	PCO3	PCO3
Danfoss controller	AK-PC530	AK-PC530
Carel controller	mRACK	mRACK
Dixell controller	XC1015D	XC1015D

¹ Data calculated with Bitzer software at Te=-35°C ; Tc=+40°C ; Temp. of aspirated gas =20°C ;subcooling of 0°K liquid (pursuant to directive EN12900).

Value for absorbed power does not include condenser fans, the optional one installed on the casing and it refers to the absorption of the compressors without power-factor correction capacitors.

² Bitzer compressors specifications as per software

³ The data shown in the table refer to the enclosed version with full oil circuit

EPTA TECHNICAL DOCUMENTATION PRODUCT: EPTAGLOO DOC. NO. QSM000406A CHAP.NO.:020 1\CHAPTER:DESCRIZIONE / DATI TECNICI	REVISION STATUS		APPROVAL	PAGE 18 of 26
	ORD	DATE	DTF.RD	DATE 1ST ISSUE
	E	20/11/2012		UPDATES
	F	29/10/2014	BITZER NEWECOLINE and SF	MKT
G	20/12/2016	UPDATE FOR R407F		

Medium temperature applications (R404A) – 4 Bitzer compressors

TABLE 8A

Pack model	4 x 4TES-9Y	4 x 4PES-12Y	4 x 4NES-14Y
Supply voltage	400 / 3 / 50	400 / 3 / 50	400 / 3 / 50
N° of compressors	4	4	4
Refrigerant	R404A	R404A	R404A
Cooling capacity ¹ (W)	92800	106000	126400
Absorbed power ¹ (W)	36200	41800	49320
Maximum absorption ² (A)	79.6	90.8	106.4

Pipework			
Discharge pipe diameter (mm)	42	54	54
Return pipe diameter (mm)	42	42	42
Suction diameter (mm)	80	80	80

Dimensions and weight ³			
Length (mm) excluding exhaust fan	2495	2495	2495
Width (mm)	960	960	960
Height (mm)	1380	1380	1380
Weight (Kg)	1184	1210	1218

Compressor	4TES-9Y	4PES-12Y	4NES-14Y
Type	Semi-hermetic reciprocating	Semi-hermetic reciprocating	Semi-hermetic reciprocating
Brand	Bitzer	Bitzer	Bitzer
Series	Octagon	Octagon	Octagon
Lubricant Bitzer	BSE 32	BSE 32	BSE 32
Absorb. during op'n ¹ (A)	15.1	17.0	20.2
Maximum Absorption ² (A)	19.9	22.7	26.6

Receiver			
Liquid receiver volume (L)	60	60	60
Liquid diameter (inlet/outlet) (mm)	28	28	28

Electrical board (400/3/50)			
Code e.b. with MT	UQ391DMBE	UQ391DMCE	UQ391DMDE
Code e.b. with MTD	UQ391DDBE	UQ391DDCE	UQ391DDDE
Magneto-thermal protection range - compr.	(14 – 20)A	(20 - 25)A	(22 – 32)A

Carel controller	IR33Z9HR20	IR33Z9HR20	IR33Z9HR20
Danfoss controller	EKC331/T	EKC331/T	EKC331/T
Carel controller	PCO3	PCO3	PCO3
Danfoss controller	AK-PC530	AK-PC530	AK-PC530
Carel controller	mRACK	mRACK	mRACK
Dixell controller	XC1015D	XC1015D	XC1015D

¹ Data calculated with Bitzer software at Te=-10°C ; Tc=+40°C ; Temp. of aspirated gas =20°C ;subcooling of 0°K liquid (pursuant to directive EN12900).

Value for absorbed power does not include condenser fans, the optional one installed on the casing and it refers to the absorption of the compressors without power-factor correction capacitors.

² Bitzer compressors specifications as per software

³ The data shown in the table refer to the enclosed version with full oil circuit

EPTA TECHNICAL DOCUMENTATION PRODUCT: EPTAGLOO DOC. NO. QSM000406A CHAP.NO.:020 1\CHAPTER:DESCRIZIONE / DATI TECNICI	REVISION STATUS		APPROVAL	PAGE 19 of 26
	ORD	DATE	DTF.RD	DATE 1ST ISSUE
	E	20/11/2012		UPDATES
	F	29/10/2014	BITZER NEWECOLINE and SF	MKT
G	20/12/2016	UPDATE FOR R407F		

Low temperature applications (R404A) – 4 Bitzer compressors

TABLE 9A

Pack model	4 x 4TES-9Y	4 x 4PES-12Y	4 x 4NES-14Y
Supply voltage	400 / 3 / 50	400 / 3 / 50	400 / 3 / 50
N° of compressors	4	4	4
Refrigerant	R404A	R404A	R404A
Cooling capacity ¹ (W)	25920	27920	33280
Absorbed power ¹ (W)	18640	21200	24760
Maximum absorption ² (A)	79.6	90.8	106.4

Pipework			
Discharge pipe diameter (mm)	35	35	35
Return pipe diameter (mm)	28	28	35
Suction diameter (mm)	80	80	80

Dimensions and weight ³			
Length (mm) excluding exhaust fan	2495	2495	2495
Width (mm)	960	960	960
Height (mm)	1380	1380	1380
Weight (Kg)	1185	1206	1214

Compressor	4TES-9Y	4PES-12Y	4NES-14Y
Type	Semi-hermetic reciprocating	Semi-hermetic reciprocating	Semi-hermetic reciprocating
Brand	Bitzer	Bitzer	Bitzer
Series	Octagon	Octagon	Octagon
Lubricant Bitzer	BSE 32	BSE 32	BSE 32
Absorb. during op'n ¹ (A)	8.7	9.9	11.7
Maximum Absorption ² (A)	19.9	22.7	26.6

Receiver			
Liquid receiver volume (L)	60	60	60
Liquid diameter (inlet/outlet) (mm)	28	28	28

Electrical board (400/3/50)			
Code e.b. with MT	UQ391DMBE	UQ391DMCE	UQ391DMDE
Code e.b. with MTD	UQ391DDBE	UQ391DDCE	UQ391DDDE
Magneto-thermal protection range - compr.	(14 – 20)A	(20 - 25)A	(22 – 32)A

Carel controller	IR33Z9HR20	IR33Z9HR20	IR33Z9HR20
Danfoss controller	EKC331/T	EKC331/T	EKC331/T
Carel controller	PCO3	PCO3	PCO3
Danfoss controller	AK-PC530	AK-PC530	AK-PC530
Carel controller	mRACK	mRACK	mRACK
Dixell controller	XC1015D	XC1015D	XC1015D

¹ Data calculated with Bitzer software at Te=-35°C ; Tc=+40°C ; Temp. of aspirated gas =20°C ;subcooling of 0°K liquid (pursuant to directive EN12900).

Value for absorbed power does not include condenser fans, the optional one installed on the casing and it refers to the absorption of the compressors without power-factor correction capacitors.

² Bitzer compressors specifications as per software

³ The data shown in the table refer to the enclosed version with full oil circuit

EPTA TECHNICAL DOCUMENTATION	REVISION STATUS			APPROVAL	PAGE 20 of 26
PRODUCT: EPTAGLOO	ORD	DATE		DTF.RD	DATE 1ST ISSUE
DOC. NO. QSM000406A CHAP.NO.:020	E	20/11/2012	UPDATES		13/06/2007
1\CHAPTER:DESCRIZIONE / DATI TECNICI	F	29/10/2014	BITZER NEWECOLINE and SF	DICON	MKT
	G	20/12/2016	UPDATE FOR R407F		

Medium temperature applications (R404A) – 3 Bitzer compressors

TABLE 10A

Pack model	3 x 2EES-2Y	3 x 2DES-2Y	3 x 2CES-3Y
Supply voltage	400 / 3 / 50	400 / 3 / 50	400 / 3 / 50
N° of compressors	3	3	3
Refrigerant	R407F	R407F	R407F
Cooling capacity ¹ (W)	18090	21660	26760
Absorbed power ¹ (W)	6870	8370	10230
Maximum absorption ² (A)	18	22.5	27.3

Pipework			
Discharge pipe diameter (mm)	22	22	28
Return pipe diameter (mm)	22	22	28
Suction diameter (mm)	42	42	42

Dimensions and weight ³			
Length (mm) excluding exhaust fan	1995	1995	1995
Width (mm)	960	960	960
Height (mm)	1380	1380	1380
Weight (Kg)	691	692	699

Compressor	2EES-2Y	2DES-2Y	2CES-3Y
Type	Semi-hermetic reciprocating	Semi-hermetic reciprocating	Semi-hermetic reciprocating
Brand	Bitzer	Bitzer	Bitzer
Series	Octagon	Octagon	Octagon
Lubricant Bitzer	BSE 32	BSE 32	BSE 32
Absorb. during op'n ¹ (A)	4.16	4.96	6.26
Maximum Absorption ² (A)	6	7.5	9.1

Receiver			
Liquid receiver volume (L)	40	40	40
Liquid diameter (inlet/outlet) (mm)	22	22	22

Electrical board (400/3/50)			
Code e.b. with MT	UQ391AM6E	UQ391AM7E	UQ391AM8E
Code e.b. with MTD	UQ391AD6E	UQ391AD7E	UQ391AD8E
Magneto-thermal protection range - compr.	(4.5 – 6.3)A	(5.5 - 8)A	(7 – 10)A

Carel controller	IR33Z9HR20	IR33Z9HR20	IR33Z9HR20
Danfoss controller	EKC331/T	EKC331/T	EKC331/T
Carel controller	PRACK	PRACK	PRACK
Danfoss controller	AK-PC710	AK-PC710	AK-PC710

¹ Data calculated with Bitzer software at Te=-10°C ; Tc=+40°C ; Temp. of aspirated gas =20°C ;subcooling of 0°K liquid (pursuant to directive EN12900).

Value for absorbed power does not include condenser fans, the optional one installed on the casing and it refers to the absorption of the compressors without power-factor correction capacitors.

² Bitzer compressors specifications as per software

³ The data shown in the table refer to the enclosed version with full oil circuit

EPTA TECHNICAL DOCUMENTATION PRODUCT: EPTAGLOO DOC. NO. QSM000406A CHAP.NO.:020 1\CHAPTER:DESCRIZIONE / DATI TECNICI	REVISION STATUS		APPROVAL	PAGE 21 of 26
	ORD	DATE	DTF.RD	DATE 1ST ISSUE
	E	20/11/2012		UPDATES
	F	29/10/2014	BITZER NEWECOLINE and SF	MKT
G	20/12/2016	UPDATE FOR R407F		

Medium temperature applications (R404A) – 3 Bitzer compressors

TABLE 11A

Pack model	3 x 4FES-3Y	3 x 4EES-4Y	3 x 4DES-5Y
Supply voltage	400 / 3 / 50	400 / 3 / 50	400 / 3 / 50
N° of compressors	3	3	3
Refrigerant	R407F	R407F	R407F
Cooling capacity ¹ (W)	29370	36810	43260
Absorbed power ¹ (W)	11100	13920	16290
Maximum absorption ² (A)	28.5	36.6	43.5

Pipework			
Discharge pipe diameter (mm)	28	28	35
Return pipe diameter (mm)	28	35	35
Suction diameter (mm)	42	54	54

Dimensions and weight ³			
Length (mm) excluding exhaust fan	1995	1995	1995
Width (mm)	960	960	960
Height (mm)	1380	1380	1380
Weight (Kg)	735	742	756

Compressor	4FES-3Y	4EES-4Y	4DES-5Y
Type	Semi-hermetic reciprocating	Semi-hermetic reciprocating	Semi-hermetic reciprocating
Brand	Bitzer	Bitzer	Bitzer
Series	Octagon	Octagon	Octagon
Lubricant Bitzer	BSE 32	BSE 32	BSE 32
Absorb. during op'n ¹ (A)	6.75	7.95	9.52
Maximum Absorption ² (A)	9.5	12.2	14.5

Receiver			
Liquid receiver volume (L)	40	40	40
Liquid diameter (inlet/outlet) (mm)	22	22	22

Electrical board (400/3/50)			
Code e.b. with MT	UQ391AM8E	UQ391AMAE	UQ391AM8E
Code e.b. with MTD	UQ391AD8E	UQ391ADAE	UQ391AD8E
Magneto-thermal protection range - compr.	(7 - 10)A	(11 - 16)A	(11 - 16)A

Carel controller	IR33Z9HR20	IR33Z9HR20	IR33Z9HR20
Danfoss controller	EKC331/T	EKC331/T	EKC331/T
Carel controller	PRACK	PRACK	PRACK
Danfoss controller	AK-PC710	AK-PC710	AK-PC710

¹ Data calculated with Bitzer software at Te=-10°C ; Tc=+40°C ; Temp. of aspirated gas =20°C ;subcooling of 0°K liquid (pursuant to directive EN12900).

Value for absorbed power does not include condenser fans, the optional one installed on the casing and it refers to the absorption of the compressors without power-factor correction capacitors.

² Bitzer compressors specifications as per software

³ The data shown in the table refer to the enclosed version with full oil circuit

EPTA TECHNICAL DOCUMENTATION	REVISION STATUS			APPROVAL	PAGE 22 of 26
PRODUCT: EPTAGLOO	ORD	DATE		DTF.RD	DATE 1ST ISSUE
DOC. NO. QSM000406A CHAP.NO.:020	E	20/11/2012	UPDATES		13/06/2007
1\CHAPTER:DESCRIZIONE / DATI TECNICI	F	29/10/2014	BITZER NEWECOLINE and SF	DICON	MKT
	G	20/12/2016	UPDATE FOR R407F		

Medium temperature applications (R404A) – 3 Bitzer compressors

TABLE 12A

Pack model	3 x 4CES-6Y	3 x 4VES-7Y	3 x 4TES-9Y
Supply voltage	400 / 3 / 50	400 / 3 / 50	400 / 3 / 50
N° of compressors	3	3	3
Refrigerant	R407F	R407F	R407F
Cooling capacity ¹ (W)	53460	54720	66600
Absorbed power ¹ (W)	19950	20010	24330
Maximum absorption ² (A)	53.1	49.8	59.7

Pipework			
Discharge pipe diameter (mm)	35	35	42
Return pipe diameter (mm)	35	42	42
Suction diameter (mm)	54	54	67

Dimensions and weight ³			
Length (mm) excluding exhaust fan	1995	1995	1995
Width (mm)	960	960	960
Height (mm)	1380	1380	1380
Weight (Kg)	771	889	904

Compressor	4CES-6Y	4VES-7Y	4TES-9Y
Type	Semi-hermetic reciprocating	Semi-hermetic reciprocating	Semi-hermetic reciprocating
Brand	Bitzer	Bitzer	Bitzer
Series	Octagon	Octagon	Octagon
Lubricant Bitzer	BSE 32	BSE 32	BSE 32
Absorb. during op'n ¹ (A)	11.72	11.49	14
Maximum Absorption ² (A)	17.7	16.6	19.9

Receiver			
Liquid receiver volume (L)	40	40	40
Liquid diameter (inlet/outlet) (mm)	22	22	22

Electrical board (400/3/50)			
Code e.b. with MT	UQ391AMBE	UQ391AMBE	UQ391AMBE
Code e.b. with MTD	UQ391ADBE	UQ391ADBE	UQ391ADBE
Magneto-thermal protection range - compr.	(14 – 20)A	(14 – 20)A	(14 – 20)A

Carel controller	IR33Z9HR20	IR33Z9HR20	IR33Z9HR20
Danfoss controller	EKC331/T	EKC331/T	EKC331/T
Carel controller	PRACK	PRACK	PRACK
Danfoss controller	AK-PC710	AK-PC710	AK-PC710

¹ Data calculated with Bitzer software at Te=-10°C ; Tc=+40°C ; Temp. of aspirated gas =20°C ;subcooling of 0°K liquid (pursuant to directive EN12900).

Value for absorbed power does not include condenser fans, the optional one installed on the casing and it refers to the absorption of the compressors without power-factor correction capacitors.

² Bitzer compressors specifications as per software

³ The data shown in the table refer to the enclosed version with full oil circuit

EPTA TECHNICAL DOCUMENTATION PRODUCT: EPTAGLOO DOC. NO. QSM000406A CHAP.NO.:020 1\CHAPTER:DESCRIZIONE / DATI TECNICI	REVISION STATUS		APPROVAL	PAGE 23 of 26
	ORD	DATE	DTF.RD	DATE 1ST ISSUE
	E	20/11/2012		13/06/2007
	F	29/10/2014	DICON	MKT
G	20/12/2016	UPDATE FOR R407F		

Medium temperature applications (R404A) – 3 Bitzer compressors

TABLE 13A

Pack model	3 x 4PES-12Y	3 x 4NES-14Y
Supply voltage	400 / 3 / 50	400 / 3 / 50
N° of compressors	3	3
Refrigerant	R407F	R407F
Cooling capacity ¹ (W)	76200	90900
Absorbed power ¹ (W)	27090	32670
Maximum absorption ² (A)	68.1	79.8
Pipework		
Discharge pipe diameter (mm)	42	42
Return pipe diameter (mm)	42	42
Suction diameter (mm)	67	67
Dimensions and weight³		
Length (mm) excluding exhaust fan	1995	1995
Width (mm)	960	960
Height (mm)	1380	1380
Weight (Kg)	919	925
Compressor		
Type	4PES-12Y Semi-hermetic reciprocating	4NES-14Y Semi-hermetic reciprocating
Brand	Bitzer	Bitzer
Series	Octagon	Octagon
Lubricant Bitzer	BSE 32	BSE 32
Absorb. during op'n ¹ (A)	15.79	18.6
Maximum Absorption ² (A)	22.7	26.6
Receiver		
Liquid receiver volume (L)	40	40
Liquid diameter (inlet/outlet) (mm)	22	22
Electrical board (400/3/50)		
Code e.b. with MT	UQ391AMCE	UQ391AMDE
Code e.b. with MTD	UQ391ADCE	UQ391ADDE
Magneto-thermal protection range - compr.	(20 - 25)A	(22 – 32)A
Carel controller	IR33Z9HR20	IR33Z9HR20
Danfoss controller	EKC331/T	EKC331/T
Carel controller	PRACK	PRACK
Danfoss controller	AK-PC710	AK-PC710

¹ Data calculated with Bitzer software at Te=-10°C ; Tc=+40°C ; Temp. of aspirated gas =20°C ;subcooling of 0°K liquid (pursuant to directive EN12900).

Value for absorbed power does not include condenser fans, the optional one installed on the casing and it refers to the absorption of the compressors without power-factor correction capacitors.

² Bitzer compressors specifications as per software

³ The data shown in the table refer to the enclosed version with full oil circuit

EPTA TECHNICAL DOCUMENTATION PRODUCT: EPTAGLOO DOC. NO. QSM000406A CHAP.NO.:020 1\CHAPTER:DESCRIZIONE / DATI TECNICI	REVISION STATUS		APPROVAL	PAGE 24 of 26
	ORD	DATE	DTF.RD	DATE 1ST ISSUE
	E	20/11/2012		UPDATES
	F	29/10/2014	BITZER NEWECOLINE and SF	MKT
G	20/12/2016	UPDATE FOR R407F		

Low temperature applications (R404A) – 3 Bitzer compressors

TABLE 14A

Pack model	3 x 4TES-9Y	3 x 4PES-12Y	3 x 4NES-14Y
Supply voltage	400 / 3 / 50	400 / 3 / 50	400 / 3 / 50
N° of compressors	3	3	3
Refrigerant	R407F	R407F	R407F
Cooling capacity ¹ (W)	14760	15900	20010
Absorbed power ¹ (W)	11460	12120	15180
Maximum absorption ² (A)	59.7	68.1	79.8

Pipework			
Discharge pipe diameter (mm)	28	28	28
Return pipe diameter (mm)	28	28	35
Suction diameter (mm)	54	54	67

Dimensions and weight ³			
Length (mm) excluding exhaust fan	1995	1995	1995
Width (mm)	960	960	960
Height (mm)	1380	1380	1380
Weight (Kg)	896	912	928

Compressor	4TES-9Y	4PES-12Y	4NES-14Y
Type	Semi-hermetic reciprocating	Semi-hermetic reciprocating	Semi-hermetic reciprocating
Brand	Bitzer	Bitzer	Bitzer
Series	Octagon	Octagon	Octagon
Lubricant Bitzer	BSE 32	BSE 32	BSE 32
Absorb. during op'n ¹ (A)	7.86	9.08	10.55
Maximum Absorption ² (A)	19.9	22.7	26.6

Receiver			
Liquid receiver volume (L)	40	40	40
Liquid diameter (inlet/outlet) (mm)	22	22	22

Electrical board (400/3/50)			
Code e.b. with MT	UQ391AMBE	UQ391AMCE	UQ391AMDE
Code e.b. with MTD	UQ391ADBE	UQ391ADCE	UQ391ADDE
Magneto-thermal protection range - compr.	(14 – 20)A	(20 – 25)A	(22 – 32)A

Carel controller	IR33Z9HR20	IR33Z9HR20	IR33Z9HR20
Danfoss controller	EKC331/T	EKC331/T	EKC331/T
Carel controller	PRACK	PRACK	PRACK
Danfoss controller	AK-PC710	AK-PC710	AK-PC710

¹ Data calculated with Bitzer software at Te=-35°C ; Tc=+40°C ; Temp. of aspirated gas =20°C ;subcooling of 0°K liquid (pursuant to directive EN12900).

Value for absorbed power does not include condenser fans, the optional one installed on the casing and it refers to the absorption of the compressors without power-factor correction capacitors.

² Bitzer compressors specifications as per software

³ The data shown in the table refer to the enclosed version with full oil circuit

EPTA TECHNICAL DOCUMENTATION PRODUCT: EPTAGLOO DOC. NO. QSM000406A CHAP.NO.:020 1\CHAPTER:DESCRIZIONE / DATI TECNICI	REVISION STATUS		APPROVAL	PAGE 25 of 26
	ORD	DATE	DTF.RD	DATE 1ST ISSUE
	E	20/11/2012		UPDATES
	F	29/10/2014	BITZER NEWECOLINE and SF	MKT
G	20/12/2016	UPDATE FOR R407F		

Medium temperature applications (R404A) – 4 Bitzer compressors

TABLE 15A

Pack model	4 x 4TES-9Y	4 x 4PES-12Y	4 x 4NES-14Y
Supply voltage	400 / 3 / 50	400 / 3 / 50	400 / 3 / 50
N° of compressors	4	4	4
Refrigerant	R407F	R407F	R407F
Cooling capacity ¹ (W)	88800	101600	121200
Absorbed power ¹ (W)	32440	36120	43560
Maximum absorption ² (A)	79.6	90.8	106.4

Pipework			
Discharge pipe diameter (mm)	42	54	54
Return pipe diameter (mm)	42	42	42
Suction diameter (mm)	80	80	80

Dimensions and weight ³			
Length (mm) excluding exhaust fan	2495	2495	2495
Width (mm)	960	960	960
Height (mm)	1380	1380	1380
Weight (Kg)	1184	1210	1218

Compressor	4TES-9Y	4PES-12Y	4NES-14Y
Type	Semi-hermetic reciprocating	Semi-hermetic reciprocating	Semi-hermetic reciprocating
Brand	Bitzer	Bitzer	Bitzer
Series	Octagon	Octagon	Octagon
Lubricant Bitzer	BSE 32	BSE 32	BSE 32
Absorb. during op'n ¹ (A)	14	15.79	18.6
Maximum Absorption ² (A)	19.9	22.7	26.6

Receiver			
Liquid receiver volume (L)	60	60	60
Liquid diameter (inlet/outlet) (mm)	28	28	28

Electrical board (400/3/50)			
Code e.b. with MT	UQ391DMBE	UQ391DMCE	UQ391DMDE
Code e.b. with MTD	UQ391DDBE	UQ391DDCE	UQ391DDDE
Magneto-thermal protection range - compr.	(14 – 20)A	(20 - 25)A	(22 – 32)A

Carel controller	IR33Z9HR20	IR33Z9HR20	IR33Z9HR20
Danfoss controller	EKC331/T	EKC331/T	EKC331/T
Carel controller	PRACK	PRACK	PRACK
Danfoss controller	AK-PC710	AK-PC710	AK-PC710

¹ Data calculated with Bitzer software at Te=-10°C ; Tc=+40°C ; Temp. of aspirated gas =20°C ;subcooling of 0°K liquid (pursuant to directive EN12900).

Value for absorbed power does not include condenser fans, the optional one installed on the casing and it refers to the absorption of the compressors without power-factor correction capacitors.

² Bitzer compressors specifications as per software

³ The data shown in the table refer to the enclosed version with full oil circuit

EPTA TECHNICAL DOCUMENTATION PRODUCT: EPTAGLOO DOC. NO. QSM000406A CHAP.NO.:020 1\CHAPTER:DESCRIZIONE / DATI TECNICI	REVISION STATUS		APPROVAL	PAGE 26 of 26
	ORD	DATE	DTF.RD	DATE 1ST ISSUE
	E	20/11/2012		13/06/2007
	F	29/10/2014	DICON	MKT
G	20/12/2016	UPDATE FOR R407F		

Low temperature applications (R404A) – 4 Bitzer compressors

TABLE 16A

Pack model	4 x 4TES-9Y	4 x 4PES-12Y	4 x 4NES-14Y
Supply voltage	400 / 3 / 50	400 / 3 / 50	400 / 3 / 50
N° of compressors	4	4	4
Refrigerant	R407F	R407F	R407F
Cooling capacity ¹ (W)	19680	21200	26680
Absorbed power ¹ (W)	15280	16160	20240
Maximum absorption ² (A)	79.6	90.8	106.4

Pipework			
Discharge pipe diameter (mm)	28	28	35
Return pipe diameter (mm)	28	28	35
Suction diameter (mm)	67	67	80

Dimensions and weight ³			
Length (mm) excluding exhaust fan	2495	2495	2495
Width (mm)	960	960	960
Height (mm)	1380	1380	1380
Weight (Kg)	1192	1213	1221

Compressor	4TES-9Y	4PES-12Y	4NES-14Y
Type	Semi-hermetic reciprocating	Semi-hermetic reciprocating	Semi-hermetic reciprocating
Brand	Bitzer	Bitzer	Bitzer
Series	Octagon	Octagon	Octagon
Lubricant Bitzer	BSE 32	BSE 32	BSE 32
Absorb. during op'n ¹ (A)	7.86	9.08	10.44
Maximum Absorption ² (A)	19.9	22.7	26.6

Receiver			
Liquid receiver volume (L)	60	60	60
Liquid diameter (inlet/outlet) (mm)	28	28	28

Electrical board (400/3/50)			
Code e.b. with MT	UQ391DMBE	UQ391DMCE	UQ391DMDE
Code e.b. with MTD	UQ391DDBE	UQ391DDCE	UQ391DDDE
Magneto-thermal protection range - compr.	(14 – 20)A	(20 - 25)A	(22 – 32)A

Carel controller	IR33Z9HR20	IR33Z9HR20	IR33Z9HR20
Danfoss controller	EKC331/T	EKC331/T	EKC331/T
Carel controller	PRACK	PRACK	PRACK
Danfoss controller	AK-PC710	AK-PC710	AK-PC710

¹ Data calculated with Bitzer software at Te=-35°C ; Tc=+40°C ; Temp. of aspirated gas =20°C ;subcooling of 0°K liquid (pursuant to directive EN12900).

Value for absorbed power does not include condenser fans, the optional one installed on the casing and it refers to the absorption of the compressors without power-factor correction capacitors.

² Bitzer compressors specifications as per software

³ The data shown in the table refer to the enclosed version with full oil circuit

EPTA TECHNICAL DOCUMENTATION PRODUCT: EPTAGLOO DOC. NO. QSM000406A CHAP.NO.: 020 1\CHAPTER:DESCRIZIONE / DATI TECNICI	REVISION STATUS		APPROVAL	PAGE 27 of 26
	ORD	DATE	DTF.RD	DATE 1ST ISSUE
	E	20/11/2012	UPDATES	13/06/2007
	F	29/10/2014	BITZER NEWECOLINE and SF	MKT
	G	20/12/2016	UPDATE FOR R407F	

EPTAGLOO 3GR refrigeration schematics

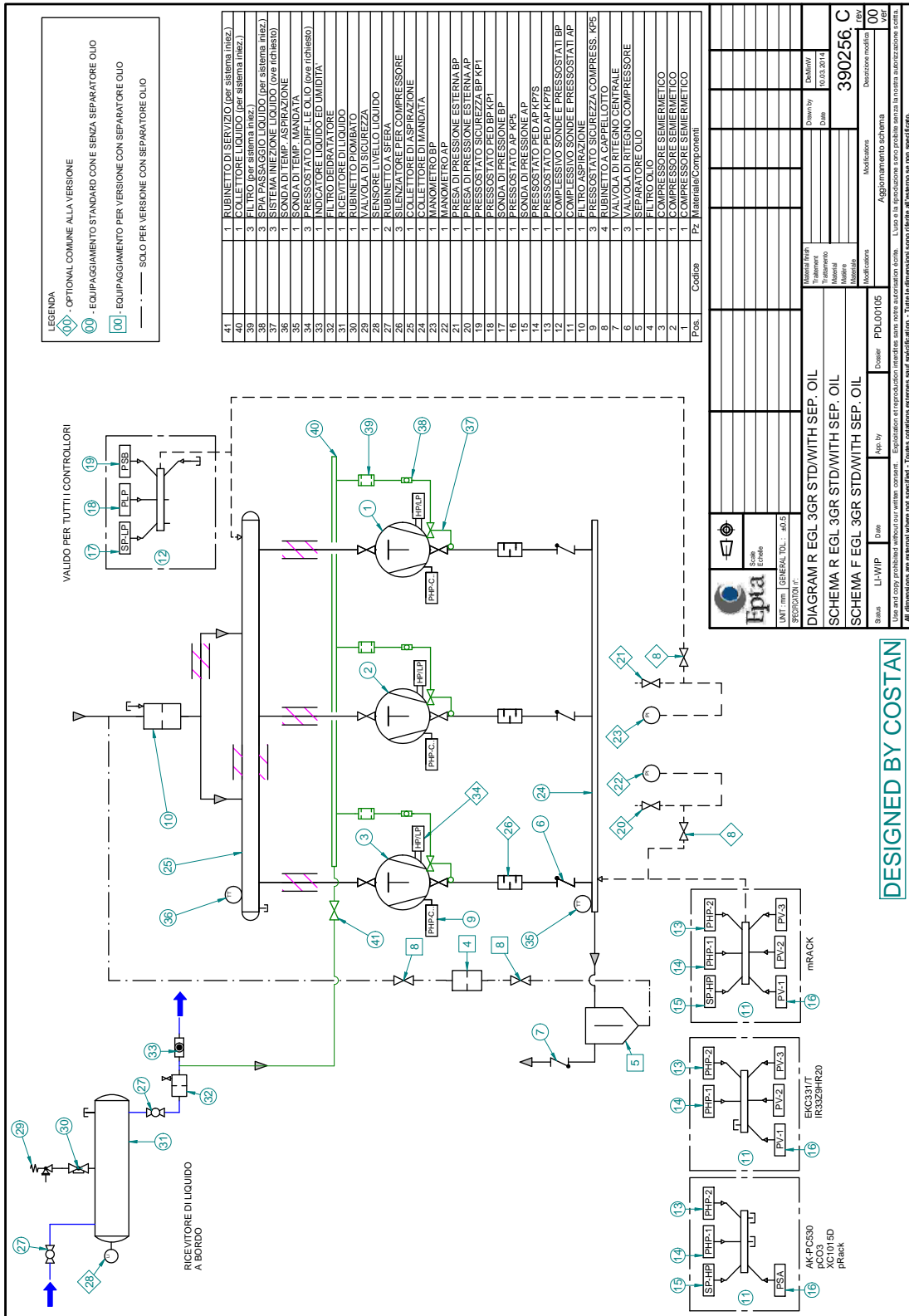

EPTA TECHNICAL DOCUMENTATION		REVISION STATUS		APPROVAL	PAGE 28 of 26
PRODUCT: EPTAGLOO		ORD	DATE	DTF.RD	DATE 1ST ISSUE
DOC. NO. QSM000406A		E	20/11/2012	UPDATES	13/06/2007
CHAP.NO.:020		F	29/10/2014	BITZER NEWECOLINE and SF	
1\CHAPTER:DESCRIZIONE / DATI TECNICI		G	20/12/2016	UPDATE FOR R407F	MKT

EPTAGLOO 3GR refrigeration schematics

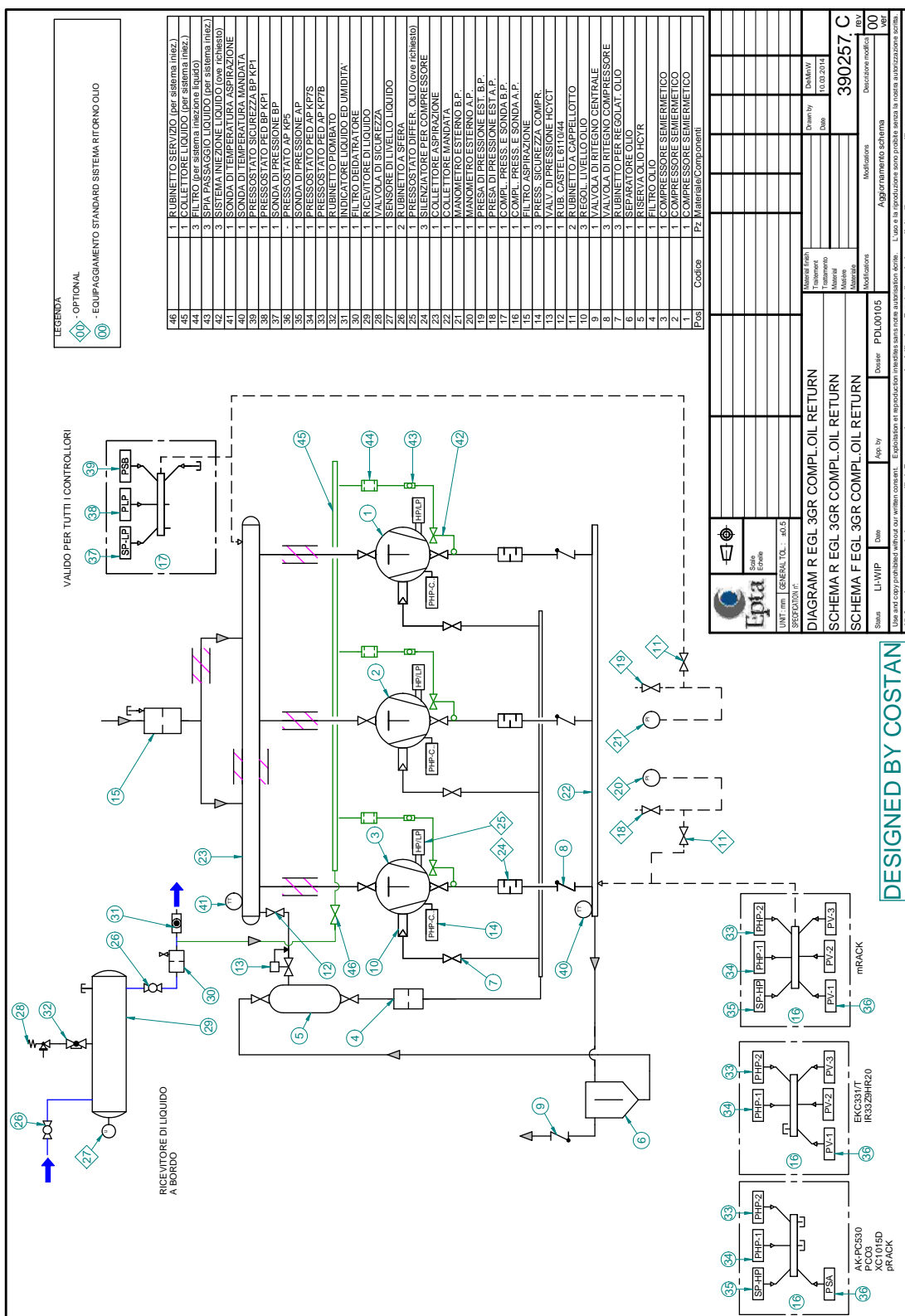

EPTA TECHNICAL DOCUMENTATION PRODUCT: EPTAGLOO DOC. NO. QSM000406A CHAP.NO.:020 1\CHAPTER:DESCRIZIONE / DATI TECNICI	REVISION STATUS		APPROVAL	PAGE 29 of 26
	ORD	DATE	DTF.RD	DATE 1ST ISSUE
	E	20/11/2012	UPDATES	13/06/2007
	F	29/10/2014	BITZER NEWECOLINE and SF	MKT
	G	20/12/2016	UPDATE FOR R407F	

EPTAGLOO 4GR refrigeration schematics

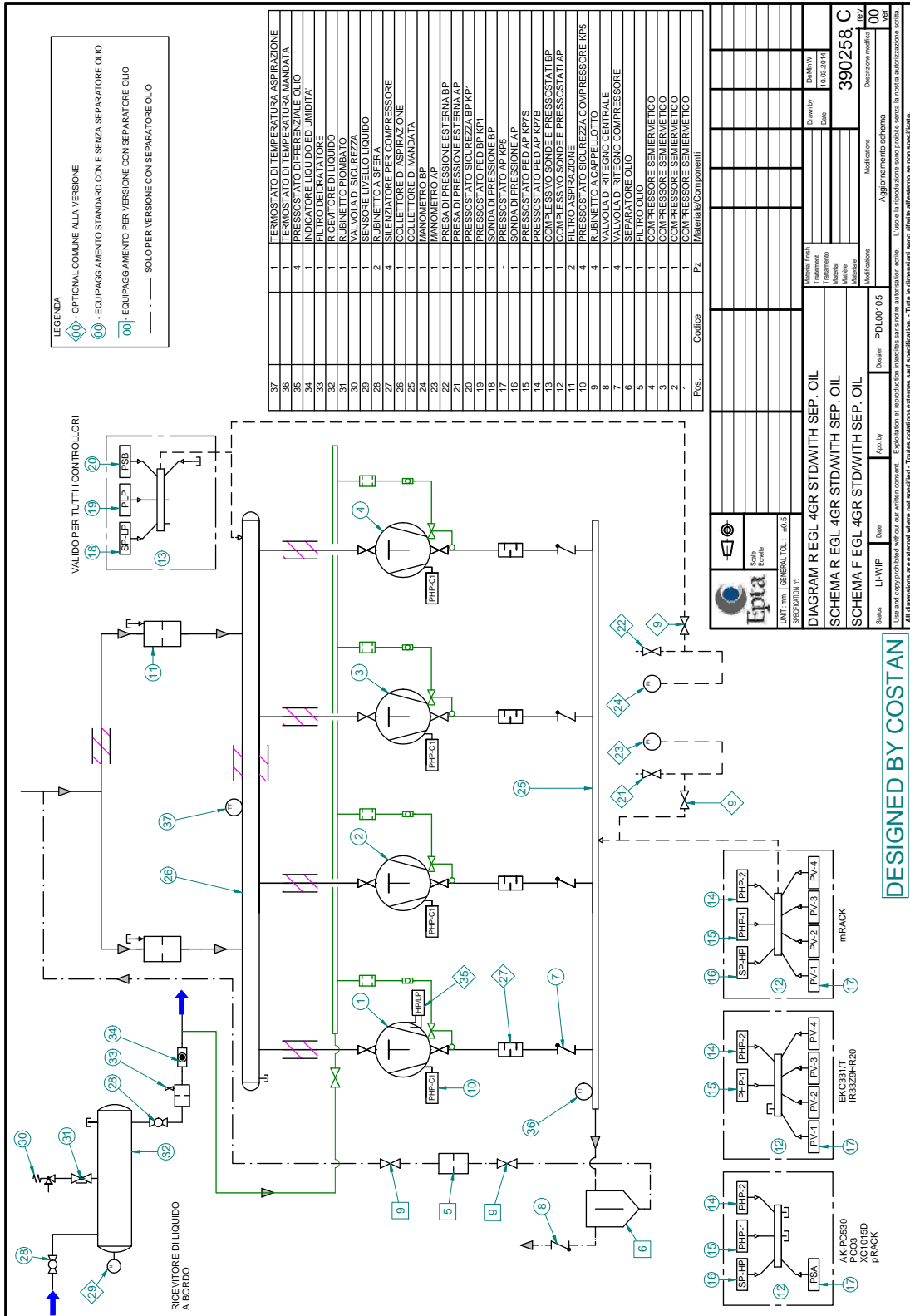

EPTA TECHNICAL DOCUMENTATION PRODUCT: EPTAGLOO DOC. NO. QSM000406A CHAP.NO.:020 1\CHAPTER:DESCRIZIONE / DATI TECNICI	REVISION STATUS		APPROVAL	PAGE 30 of 26
	ORD	DATE	DTF.RD	DATE 1ST ISSUE
	E	20/11/2012	UPDATES	13/06/2007
	F	29/10/2014	BITZER NEWECOLINE and SF	MKT
G	20/12/2016	UPDATE FOR R407F	DICON	

EPTAGLOO 4GR refrigeration schematics

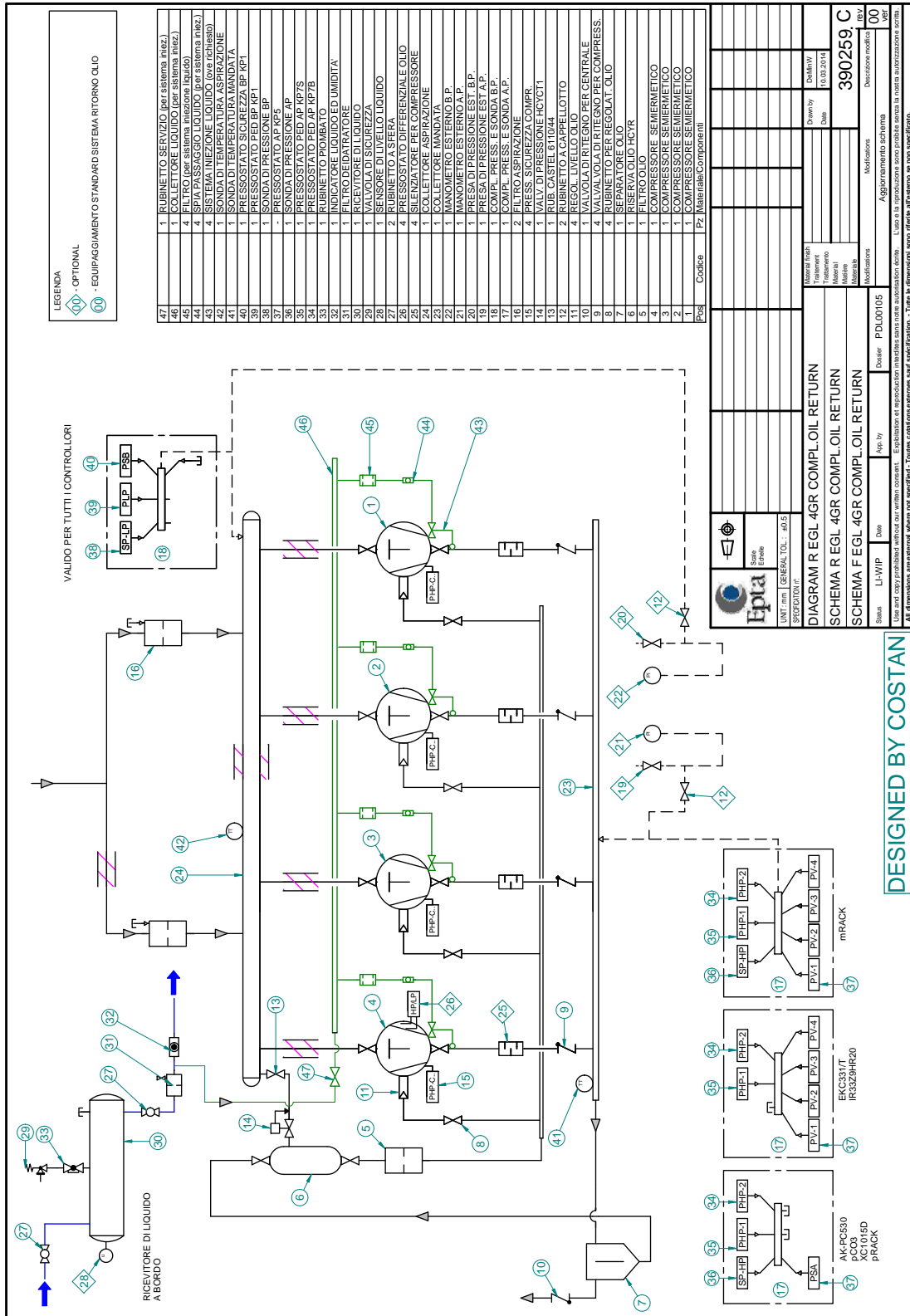

EPTA TECHNICAL DOCUMENTATION	REVISION STATUS			SIGNED FOR APPROVAL	PAGE 1 OF 5
PRODUCT: EPTAGLOO DOC. NO. QSM000406A CHAP. NO.: 030 CHAPTER: MOVIMENTAZIONE E POSIZIONAMENTO	ORD	DATE	CHANGE ORDER	DTF.RD	DATE 1ST ISSUE 13/06/2007
	C	23.02.2010	EXP. of RANGE		
	D	29.10.2014	BITZER NEWECOLINE	DICON	ISSUE MKT
	E	20.12.2016	UPDATE FOR R407F		

030 – HANDLING AND POSITIONING

To ensure correct handling and positioning of the machine, it is important to observe the following precautions. All the operations described below must be carried out in compliance with current safety regulations both with respect to the equipment and to the methods used. Only authorized personnel must be allowed to carry out these operations.

Correct sequence of operations:

- Upon receiving the unit, check it to ensure it has not been damaged. If it has, contact your nearest Epta service centre.
- As a standard, the unit is secured to wooden bars. Check to ensure that they are fastened securely before lifting the unit.
- Make sure that the lifting capacity of the forklift truck is adequate for the weight of the unit by checking the weight shown on the serial plate of the unit.
- Insert the forklift truck prongs through the space between frame and wooden base, as shown in Figure 1 and 2, and check that the unit is balanced and stable before lifting and moving it. Maximum dimensions including the wooden base, are indicated in Figure 2

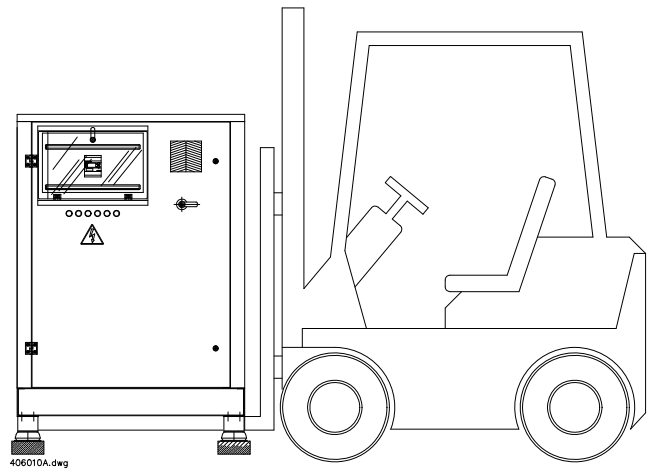

FIG.1

EPTA TECHNICAL DOCUMENTATION	REVISION STATUS			SIGNED FOR APPROVAL	PAGE 1 OF 5
PRODUCT: EPTAGLOO DOC. NO. QSM000406A CHAP. NO.: 030 CHAPTER: MOVIMENTAZIONE E POSIZIONAMENTO	ORD	DATE	CHANGE ORDER	DTF.RD	DATE 1ST ISSUE
	C	23.02.2010	EXP. of RANGE		13/06/2007
	D	29.10.2014	BITZER NEWECOLINE	DICON	ISSUE
	E	20.12.2016	UPDATE FOR R407F		MKT

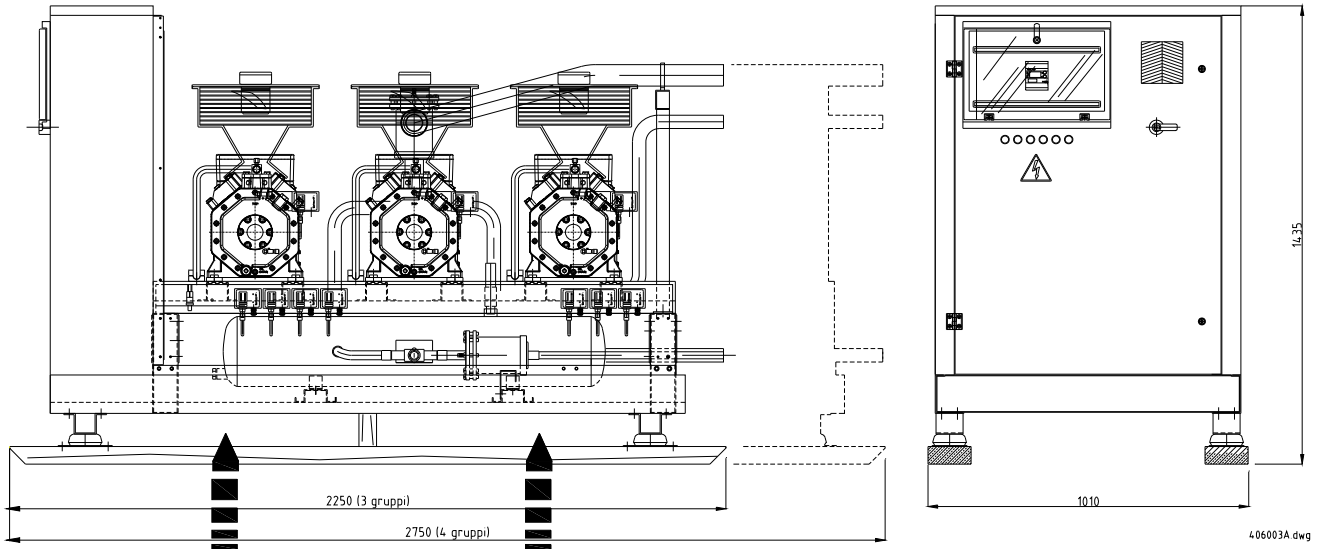

FIG.2

If a crane is used for lifting operations, you can proceed in the way shown in Figure 3. Place two round steel bars through the vibration dampening supports; put through the end of these bars two lifting straps (check their maximum capacity before use) and place two spacers (e.g. wood) between them and the pack to prevent friction of the straps against the machine panels.

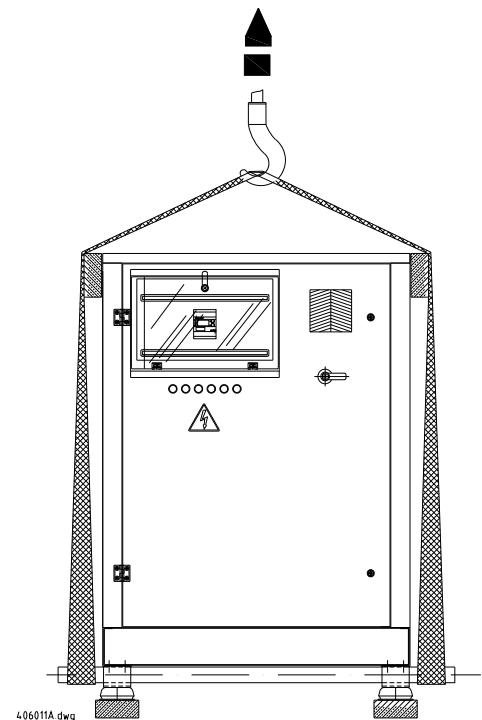

FIG.3



Do not stand in the handling area during pack lifting operations.

EPTA TECHNICAL DOCUMENTATION	REVISION STATUS			SIGNED FOR APPROVAL	PAGE 1 OF 5
PRODUCT: EPTAGLOO DOC. NO. QSM000406A CHAP.NO.: 030 CHAPTER: MOVIMENTAZIONE E POSIZIONAMENTO	ORD	DATE	CHANGE ORDER	DTF.RD	DATE 1ST ISSUE 13/06/2007
	C	23.02.2010	EXP. of RANGE		
	D	29.10.2014	BITZER NEWECOLINE	DICON	ISSUE MKT
	E	20.12.2016	UPDATE FOR R407F		

Installation indoors/outdoors

If the pack is not immediately installed in the place where it will be used but is temporarily stored outdoors, we recommend you follow a few easy precautions:.

- Keep dry and in an adequately sheltered place
- Do not rest any heavy object on the top of the unit. The sheet metal panels of the top have only a padding function and are not designed to support weights.
- Do not climb onto the top of the unit. This operation is not only dangerous but will also cause damage to the panels, which may become deformed and prevent proper closing.

Weight of 3 compressor version

Bitzer – TN – R404A/R407F

Model TN 3GR	2EES-2Y	2DES-2Y	2CES-3Y	4FES-3Y	4EES-4Y	4DES-5Y
Weight of unit (kg) ¹	691	692	699	735	742	756

Model TN 3GR	4CES-6Y	4VES-7Y	4TES-9Y	4PES-12Y	4NES-14Y
Weight of unit (kg) ¹	771	889	904	919	925

Bitzer – BT – R404A

Model BT 3GR	4FES-3Y	4EES-4Y	4DES-5Y	4CES-6Y	4TES-9Y	4PES-12Y	4NES-14Y
Weight of unit (kg)	734	741	745	761	891	907	923

Bitzer – BT – R407F

Model BT 3GR	4TES-9Y	4PES-12Y	4NES-14Y
Weight of unit (kg)	896	912	928

¹ The weights shown in the table refer to the enclosed version with full oil circuit

EPTA TECHNICAL DOCUMENTATION	REVISION STATUS			SIGNED FOR APPROVAL	PAGE 1 OF 5
PRODUCT: EPTAGLOO DOC. NO. QSM000406A CHAP.NO.: 030 CHAPTER: MOVIMENTAZIONE E POSIZIONAMENTO	ORD	DATE	CHANGE ORDER	DTF.RD	DATE 1ST ISSUE 13/06/2007
	C	23.02.2010	EXP. of RANGE		
	D	29.10.2014	BITZER NEWECOLINE	DICON	ISSUE MKT
	E	20.12.2016	UPDATE FOR R407F		

Weight of 4 compressor version

Bitzer – TN – R404A/R407F

Model TN 4GR	4TES-9Y	4PES-12Y	4NES-14Y
Weight of unit (kg)	1184	1210	1218

Bitzer – BT – R404A

Model BT 4GR	4TES-9Y	4PES-12Y	4NES-14Y
Weight of unit (kg)	1185	1206	1214

Bitzer – BT – R407F

Model BT 4GR	4TES-9Y	4PES-12Y	4NES-14Y
Weight of unit (kg)	1192	1212	1221

EPTA TECHNICAL DOCUMENTATION	REVISION STATUS			SIGNED FOR APPROVAL	PAGE 1 OF 5
PRODUCT: EPTAGLOO DOC. NO. QSM000406A CHAP.NO.:030 CHAPTER: MOVIMENTAZIONE E POSIZIONAMENTO	ORD	DATE	CHANGE ORDER	DTF.RD	DATE 1ST ISSUE
	C	23.02.2010	EXP. of RANGE		13/06/2007
	D	29.10.2014	BITZER NEWECOLINE	DICON	ISSUE
	E	20.12.2016	UPDATE FOR R407F		MKT

Location requirements

System efficiency and adequate maintenance can be ensured by choosing an appropriate location. Sufficient room must be allowed around the unit so that maintenance operations may be carried out safely by authorized personnel. Make sure that the grilles and vents provided for ventilation in the plant room are unobstructed and that any mechanical ventilation devices are in perfect working order.

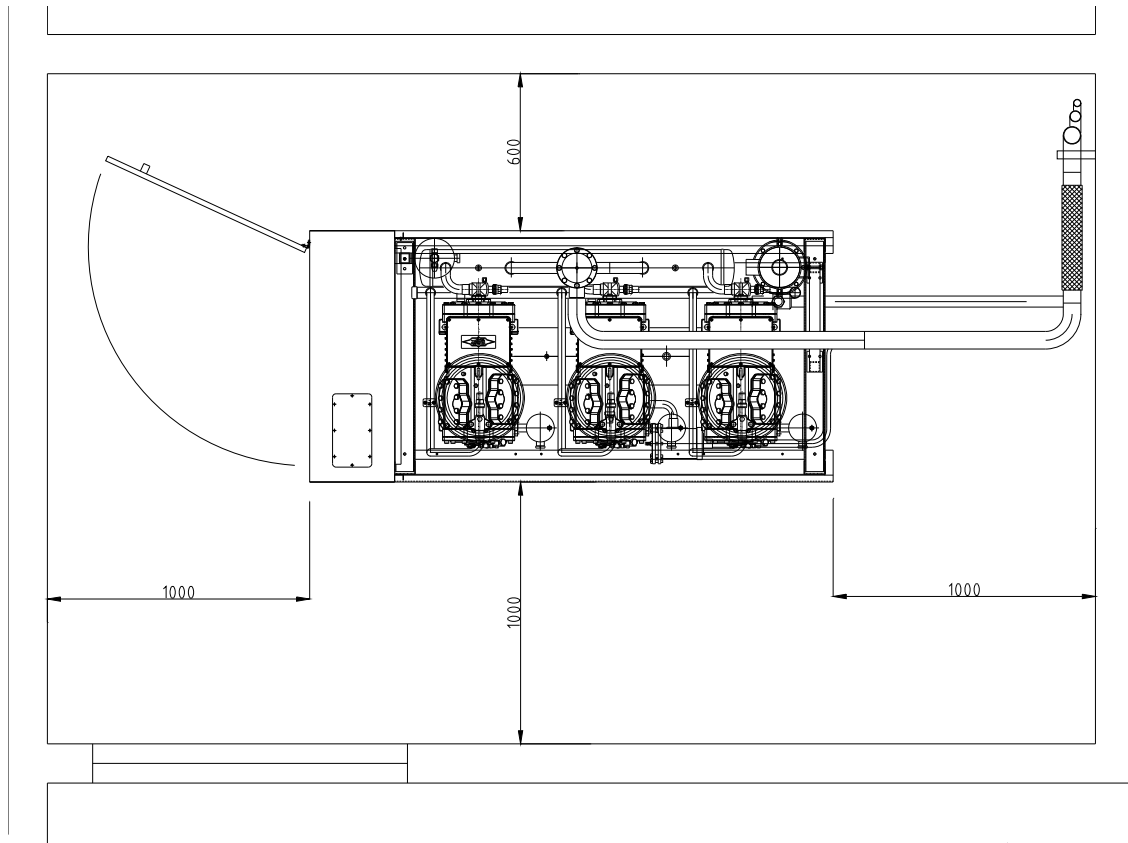

FIG. 4

COSTAN TECHNICAL DOCUMENTATION	REVISION STATUS			TRUE COPY OF THE SIGNED ORIGINAL	PAGE 7 OF 18
PRODUCT: EPTAGLOO	ORD	DATE	CHANGE ORDER		DATE OF 1st ISSUE 13/June/07
DOC. no. QSM0000406A CHAP. No.: 040	A	18.Dec.2008	UPDATE		
CHAPTER: INSTALLATION	B	28.July.2009	UPDATE C		
	C	23.Feb.2010	RANGE EXTENSION		
	D	11.Nov..2010	SAFETY VALVE ADDED		ISSUED BY MKT

040 - INSTALLATION

Take the protective cardboard packaging (if provided) off the equipment and position this wherever it is to be installed. Then remove both handling skids. Being potentially hazardous, packaging components (plastic bags, polystyrene, cardboard, nails, etc.) must never be left within the reach of children, but must be disposed of in accordance with applicable regulations.

For correct operation it is important to lay the machine horizontally.

Use shims to correct any unevenness existing on the laying surface. Take the enclosure panels (if any) off the equipment and then check that this is level **with reference to a spirit level rested on the suction header support.**

Then secure the system to the base stiffly using screw anchors and the fastening holes on the machine's vibration dampening pads.

Put the enclosure panels back in place.

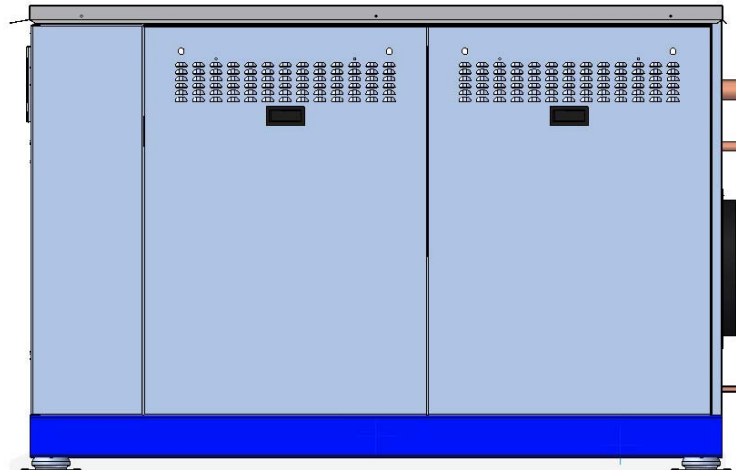

Installation in machine rooms

Non-standard plant rooms must satisfy the requirements established by standards EN 378-3. The provisions concerning dimensions, construction, accessibility and ventilation must be especially complied with.

If the plant room enjoys **natural ventilation**, the total area of natural ventilation openings must be at least (EN378-3:2002 5.5):

$$A = 0,14 \times m^{1/2}$$

where:

A = is the free opening in square meters;

m = is the mass in kilos of the refrigerant fluid with the greatest charge, having one part whatsoever in the dedicated plant room;

0,14= is the ratio between the area and the mass – in square meters – divided by the square root of the kilos

The free flow of air from windows, grids and outlets or pipework must not be hampered by walls or barriers, enclosing walls, buildings or other means of obstruction. Mind the density of the refrigerating fluid.

Mechanical ventilation, if any, must be ensured by fans able to exchange the air in the plant room, and at least:

$$V = 14 \times m^{2/3}$$

COSTAN TECHNICAL DOCUMENTATION		REVISION STATUS		TRUE COPY OF THE SIGNED ORIGINAL	PAGE 8 OF 18	
PRODUCT: EPTAGLOO		ORD	DATE		CHANGE ORDER	DATE OF 1st ISSUE
DOC. no. QSM0000406A CHAP. No.: 040		A	18.Dec.2008		UPDATE	13/June/07
CHAPTER: INSTALLATION		B	28.July.2009		UPDATE C	
		C	23.Feb.2010	RANGE EXTENSION		
		D	11.Nov..2010	SAFETY VALVE ADDED	ISSUED BY MKT	

where:

V = is the air flow rate in liters per second;

m = is the mass in kilos of the refrigerant fluid with the greatest charge, having one part whatsoever in the dedicated plant room;

14 = is the conversion factor

The ventilation system must renew the air in the room 15 times per hour.

It must be possible to operate the fans from both inside and outside the plant room, and when the special plant room is installed in a basement, the outside plant room control switch must be on ground floor.

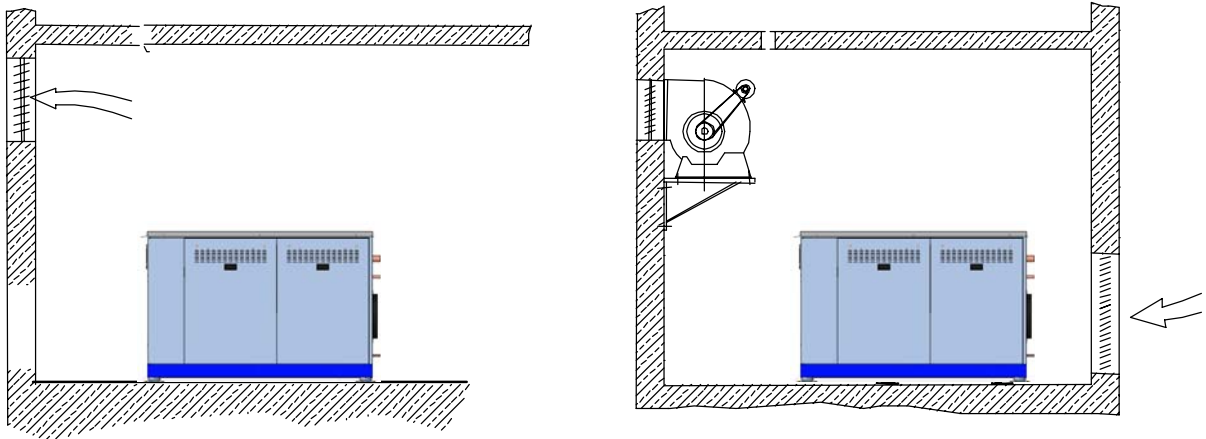

COSTAN TECHNICAL DOCUMENTATION		REVISION STATUS		TRUE COPY OF THE SIGNED ORIGINAL	PAGE 9 OF 18	
PRODUCT: EPTAGLOO		ORD	DATE		CHANGE ORDER	DATE OF 1st ISSUE
DOC. no. QSM0000406A CHAP. No.: 040		A	18.Dec.2008		UPDATE	13/June/07
CHAPTER: INSTALLATION		B	28.July.2009		UPDATE C	
		C	23.Feb.2010		RANGE EXTENSION	
		D	11.Nov..2010	SAFETY VALVE ADDED	ISSUED BY MKT	

Outdoor installation

If installation is outdoors it will be necessary to carefully select the position of the equipment, in order to avoid noise pollution and fire hazards.

To minimize noise pollution, position the equipment as far from houses as possible and far from possible noise-reflecting sources.

To minimize fire hazards, do not position the equipment next to flammable material. A fire event would raise the pressure in the liquid receiver vessel and consequently cause a discharge of refrigerant in the atmosphere.

Positioning the equipment with the electrical panel facing north will make reading the controller display easier and will protect the polycarbonate casing.

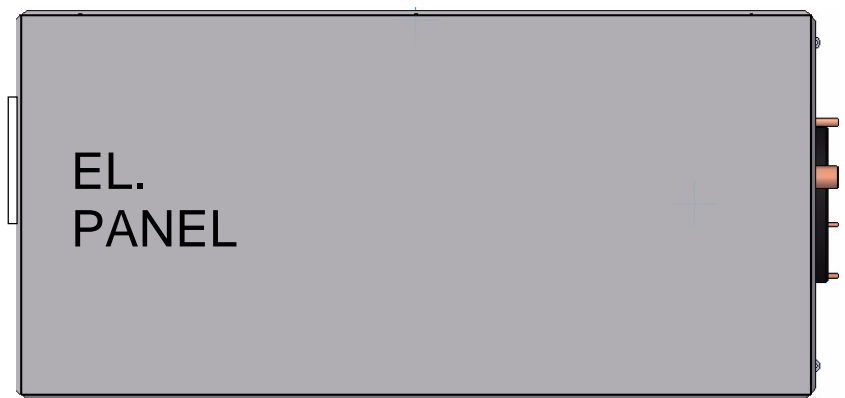
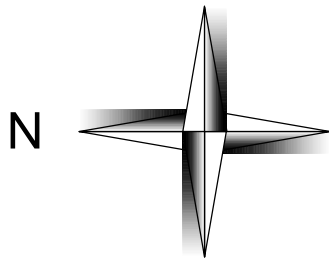

Detectors and alarms

When plant rooms are near areas in which people are present on a regular basis, restricted areas of difficult evacuation, detectors and alarms must be installed as established by standards EN378-3 in order to speedily give warning of any hazardous concentration of cooling fluid vapor in the air.

Such devices must operate an attended alarm and/or a noticeable alarm that may enable the consequent actions by the personnel.

Equipment serviceability

To access the system's internal parts in versions with indoor and outdoor enclosure, it is necessary to remove the casing panels using the appropriate key.

To set or service the electronic module (controller box), open the door using the appropriate key that only the authorized technical personnel has.

Power connections

The electrical board was designed to operate on 380V-400V/3Ph/50-60Hz and 220V-230V/3Ph/50-60Hz.

To select operating voltage it is necessary to relocate the jumpers on the auxiliary transformer as appropriate. The electrical board must be supplied power using a cable with a cross-section suitable for the equipment's power rating and for the laying conditions existing in the place of installation. The serial number plate on the machine shows, among other details, maximum electric power. This value is also indicated in the relevant table, in the DESCRIPTION / TECHNICAL DETAILS section of this manual. It is the electrician's duty to design the wiring

COSTAN TECHNICAL DOCUMENTATION		REVISION STATUS		TRUE COPY OF THE SIGNED ORIGINAL	PAGE 10 OF 18	
PRODUCT: EPTAGLOO		ORD	DATE		CHANGE ORDER	DATE OF 1st ISSUE
DOC. no. QSM0000406A CHAP. No.: 040		A	18.Dec.2008		UPDATE	13/June/07
CHAPTER: INSTALLATION		B	28.July.2009		UPDATE C	
		C	23.Feb.2010		RANGE EXTENSION	
		D	11.Nov..2010	SAFETY VALVE ADDED	ISSUED BY MKT	

and earthing systems in accordance with applicable regulations 64-8 (Italian Law 46 - 5 March 1990).

For equipment installed indoors, power cables must enter the board from above, through a hole drilled on the appropriate plate, which is located above the master switch.

For equipment installed outdoors the power cables must enter from below, using the plate at the bottom of the electrical board (the plate is on the right and is accessed by opening the electrical panel).

For the purposes of maintaining the electrical board's protection rating it is necessary to use the appropriate grommet.

All machine parts are connected to the earth system lead (yellow-green).



COSTAN disclaims all liability for incorrectly set-up wiring systems or which are not in conformity with the applicable EN standards.



The fitter must connect the machine to the earthing system of the building.



Short-circuit hazard: when drilling the hole through which cables are going to run it is necessary to exercise maximum caution and prevent metal chips from entering the electrical panel.



COSTAN disclaims all liability for untimely triggering due to incorrect differential relay setting or accidents caused by lack of coordination between the differential relay setting and the earthing system.

The installation of an RCD upstream of the power source does not ensure protection selectivity, since in the event that the RCD tripped the entire refrigerating system would be shut down.

If an RCD is required, request it when ordering the relevant electrical panel. This ensures both safety and on-going service since each component is associated to a suitable RCD that in case of tripping only shuts down the circuit part affected by the fault.



No residual current device for the pack must be installed upstream of the power source. In the event that an RCD for the entire refrigeration system is needed, it is advisable to forward the request at the time of ordering.

COSTAN TECHNICAL DOCUMENTATION		REVISION STATUS		TRUE COPY OF THE SIGNED ORIGINAL	PAGE 11 OF 18	
PRODUCT: EPTAGLOO		ORD	DATE		CHANGE ORDER	DATE OF 1st ISSUE
DOC. no. QSM0000406A CHAP. No.: 040		A	18.Dec.2008		UPDATE	13/June/07
CHAPTER: INSTALLATION		B	28.July.2009		UPDATE C	
		C	23.Feb.2010		RANGE EXTENSION	
		D	11.Nov..2010	SAFETY VALVE ADDED	ISSUED BY MKT	

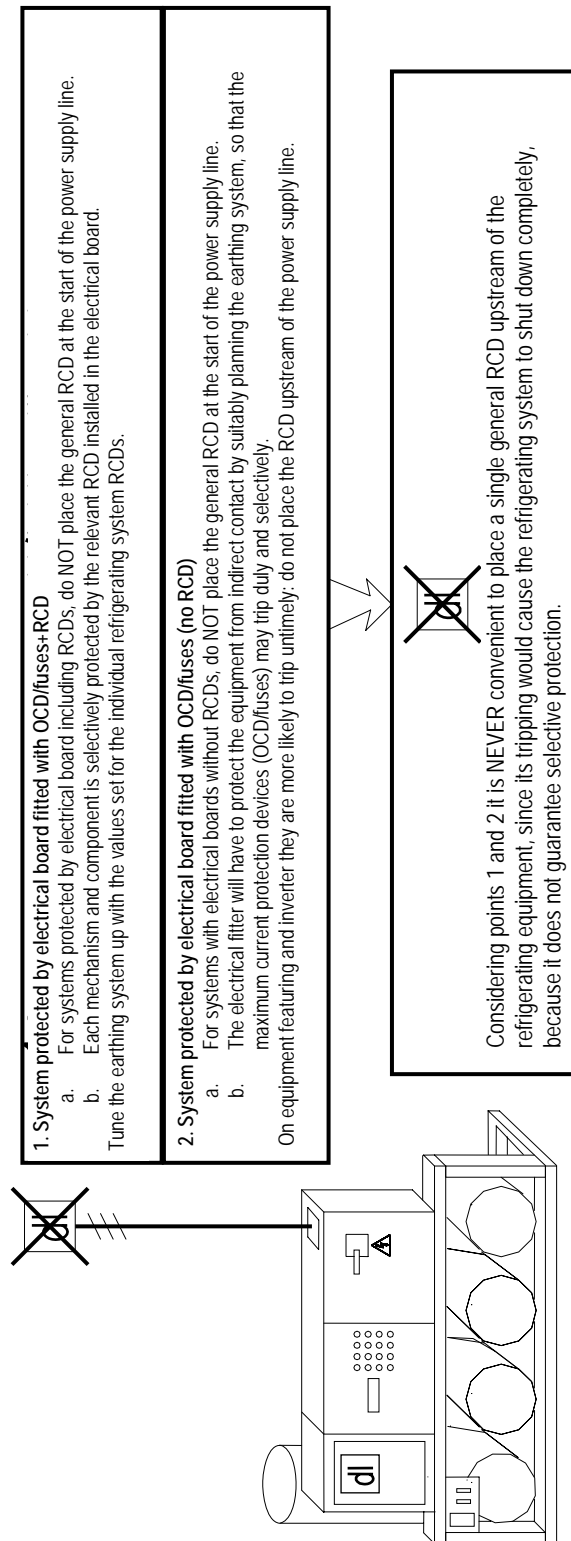

For a detailed description of the electrical components, reference is made to the "ELECTRICAL PANEL TECHNICAL SPECIFICATIONS" section.

Ensure that the cables not having spring-terminals (e.g. motor power cables connected to contactors) are tightly secured to the terminal-strip. During transportation and handling vibrations

COSTAN TECHNICAL DOCUMENTATION		REVISION STATUS			TRUE COPY OF THE SIGNED ORIGINAL	PAGE 12 OF 18
PRODUCT: EPTAGLOO		ORD	DATE	CHANGE ORDER		DATE OF 1st ISSUE
DOC. no. QSM0000406A CHAP. No.: 040		A	18.Dec.2008	UPDATE		13/June/07
CHAPTER: INSTALLATION		B	28.July.2009	UPDATE C		
		C	23.Feb.2010	RANGE EXTENSION		
		D	11.Nov..2010	SAFETY VALVE ADDED	ISSUED BY MKT	

may have loosened them. Check the wiring of the electrical panel and make sure that the cable sheaths do not touch the refrigerant pipes or the compressor. Also ensure that no component undergoes wear due to friction.

Refrigerating connection

The equipment is supplied including;

- set of filtering elements (cartridges)
- pressurized dry-air in the refrigerating circuit.

The pipework for connection to the system are located at the rear of the equipment. When delivered, the discharge pipe leading to the condenser is blocked; all other valves leading to the open are closed. Take off the copper disks, open the taps and scavenge the pressurized air before connecting the unit up to the system. Use a stiff annealed copper pipe suitable for refrigeration systems.

Certain basic rules have to be followed when setting up R404A systems. Brazing must be done in nitrogen gas atmosphere to prevent the formation of system-damaging residue. It is most important that the fitter keep to the following instructions:

- Use nitrogen gas suitable for refrigeration purposes, which is marked "R".
- Connect one end of the pipe to be brazed to the nitrogen tank using a pressure-reducing valve. To adjust the pressure correctly, remember that the flow of nitrogen must be only just perceived by the palm of the hand. Braze as usual.

Place BOA flexible vibration absorbers between the equipment and the system's fixed pipes; install shutoff valves on the discharge and condenser return lines, on the liquid line and on the suction line, referring to the connection diagrams contained in the equipment's technical literature and to the instructions in the Use and Maintenance Instructions for refrigerating systems QSM000446A_ (for systems serviced by Epta).

Fit one pressure gauge connection (Schrader valve) on the suction stretch and one on the liquid line for evacuating (vacuum) operations and for the leak test.

Introduce an initial amount of oil into the oil reserve through the filling connection 1/4"SAE located on the inlet valve (shut the valve beforehand) until the oil level reaches the upper viewer. The approximate amount to be let in ranges from 6 to 16 liters, depending on the reservoir model installed (HCYR 80, HCYR 120 or HCYR 200). Then open the valve. When located externally, safety valves (pressure relief valves) must be suitably protected from getting soiled and affected by the elements;

The position of outdoor-leading relief pipework branching off from the safety valves must ensure that no obstruction hazard exists and must avoid any personal or property damage when the refrigerant is released. Complete suction line insulation.

The equipment termed "refrigerating unit" cannot work on its own and must be included in the set termed "system". When inoperative and not connected up to a system, some pack versions contain pressure vessels, that, due to a possible refrigerant accumulation, may entail a potential hazard in case of fire. Such vessels, named liquid receivers, are duly protected by safety valves ensuring refrigerant discharge.

If the pack is delivered without an on-board liquid receiver, it is the installer's responsibility to fit the receiver with suitable safety valves providing for refrigerant discharge at the time when the pack is connected up to the other system components, i.e. to pressure vessels that may be subject to a pressure rise in case of fire.

Neither the unit nor the system include vessels containing an independent source of heat.

COSTAN TECHNICAL DOCUMENTATION	REVISION STATUS			TRUE COPY OF THE SIGNED ORIGINAL	PAGE 13 OF 18
PRODUCT: EPTAGLOO	ORD	DATE	CHANGE ORDER		DATE OF 1st ISSUE
DOC. no. QSM0000406A CHAP. No.: 040	A	18.Dec.2008	UPDATE		13/June/07
CHAPTER: INSTALLATION	B	28.July.2009	UPDATE C		
	C	23.Feb.2010	RANGE EXTENSION		
	D	11.Nov..2010	SAFETY VALVE ADDED		ISSUED BY MKT

When located outdoors, safety valves (pressure relief valves) must be suitably protected from getting soiled and being affected by the elements.

When connected up to the rest of the system components, therefore to pressure vessels that may be subject to a pressure increase in case of fire, these will be fitted with the appropriate safety valves that guarantee the discharge of refrigerant.

Below are some regulations covering the installation of systems that use POE oils and R404A gas refrigerant. For more detailed information and in case of doubt, contact the Epta after-sales service.

	<p>The semi-hermetic compressors used on the Eptagloo equipment use polyester oil (POE) as lubricant. A drawback of this oil, which is compatible with chlorine-free refrigerants (HFC), is that it is very sensitive to environmental humidity (strong hygroscopicity), which means that certain rules have to be observed as regards use, in order not to jeopardize its functional characteristics. All oil containers must stay sealed until the oil has to be introduced into the compressor. Avoid leaving the inside of the compressors and parts of the refrigeration circuit in connection with the outside even during routine system maintenance. Never pour left-over lubricant into damp-permeable containers (e.g. plastic containers) but keep in the original metal can.</p>
---	---

Visual inspection of the equipment

All permanent connections must be individually appraised by duly qualified and experienced personnel.

Pressure-tightness test

The dimensions of the safety valve and associated relief pipe were chosen in order to avoid excessive pressure increases in vessels not protected by safety pressure switch in case of a fire event, as per the instructions in European standards EN 13136.

	<p>Check that the lead seal on the valve located between the liquid receiver and the safety valve is intact. Absolutely avoid tampering with the lead seal unless the safety valve is replaced.</p>
---	--

This test must be performed after visual inspection.

Before and during the test, every measure to prevent hazards to persons and property in case of explosion must be taken.

The pressure-tightness test is performed with equal pressure values on both sides of the system:

- High pressure side: test pressure = 16 bar ($PSa=28$ bar)
- low pressure side: test pressure = 16 bar ($PSb=17$ bar)

In order to achieve test pressure it is necessary to:

COSTAN TECHNICAL DOCUMENTATION		REVISION STATUS		TRUE COPY OF THE SIGNED ORIGINAL	PAGE 14 OF 18	
PRODUCT: EPTAGLOO		ORD	DATE		CHANGE ORDER	DATE OF 1st ISSUE 13/June/07
DOC. no. QSM0000406A CHAP. No.: 040		A	18.Dec.2008		UPDATE	
CHAPTER: INSTALLATION		B	28.July.2009		UPDATE C	
		C	23.Feb.2010		RANGE EXTENSION	
		D	11.Nov..2010	SAFETY VALVE ADDED	ISSUED BY MKT	

- shut off all those components that may be damaged (low pressure-switches, low-pressure transducers, low-pressure meters);
- open all taps and automatic valves and keep them open;

The minimum overpressure time for the system undergoing the pressure-resistance test is **6 hours** (system leakage check).

The pressure-tightness test may be performed, if this is considered useful, also for system sections shut off by taps (partial tests). The pressure test is finished when both sides of the system have been put to overpressure and no works are needed on permanent joints.

The outcome of the test must be recorded by the person in charge of the jobs.

Preparation of filters and vacuum test

When the machine is delivered, filter cores are not in place. These are supplied in air-tight containers, in numbers appropriate for initial startup and first replacement. At first place the supplied dryer cores Castel 4490/A on both filters (liquid and suction).

Dryer cartridges 4490/A must be placed in the filter using the appropriate holding set (mesh inner tube, cap and spring); cartridges 4495/C (on the suction line) only use a top cap, a bottom cap and a spring as in the instructions on the core's packaging.

Close the circuit, connect up the vacuum pump and scavenge the system and/or affected stretches. If the system contains a halide or hydrocarbon charge above 20 kg, the system must be dried and scavenged to a vacuum below 270 Pa absolute (same value for both sides, high and low pressure). Vacuum must be kept for at least 30 minutes and then dry nitrogen must be introduced. Then scavenge again to vacuum below 270 Pa absolute. Keep the system in this condition for at least 6h. Then ensure that the pressure was actually kept and introduce the system refrigerating fluid. The vacuum test may be performed, if this is considered necessary or useful, also for system sections shut off by taps (partial tests).

The charge will only be filled up when the appliances fed have reached their operating temperature.

Checking pressure switches, filling and starting up the system

The system's safety pressure switches KP7S and KP7B have a sticker on the outside, that indicates tripping pressure and serial number. Pressure switch KP7S is marked red and factory-set for a pressure of 28bar whereas pressure switch KP7B is marked blue and factory-calibrated for a pressure of 27bar. After being calibrated, the adjustment screw is sealed with lead to prevent tampering. Both pressure switches are manual-reengagement (manual *reset*) type. to reengage pressure switch KP7B, just remove the upper lid and push the green tab inwards; to *reset* pressure switch KP7S it is necessary to open the pressure switch (the reset button is up in the right corner).

	Check that the lead seals are intact; do not tamper with the adjustment screw of safety pressure switches.
---	---

	Prior to resetting safety switches manually (KP7S or KP7B), identify and remove the causes that have led to system failure.
---	--

COSTAN TECHNICAL DOCUMENTATION		REVISION STATUS		TRUE COPY OF THE SIGNED ORIGINAL	PAGE 15 OF 18	
PRODUCT: EPTAGLOO		ORD	DATE		CHANGE ORDER	DATE OF 1st ISSUE 13/June/07
DOC. no. QSM0000406A	CHAP. No.: 040	A	18.Dec.2008		UPDATE	
CHAPTER: INSTALLATION		B	28.July.2009		UPDATE C	
		C	23.Feb.2010	RANGE EXTENSION		
		D	11.Nov..2010	SAFETY VALVE ADDED	ISSUED BY MKT	

The high pressure switches protecting the compressors are set to a trip value of 26.5bar. Set the system/compressor safety low pressure switch.

Set the high pressure switches for fan unloaders and the electromechanical security (duty cycle) low pressure switch.

Perform an initial charge of refrigerant in liquid condition on the line downstream from the receiver (liquid line) using tanks with liquid-gas tap or overturning the container if this is equipped with a standard valve. These steps are necessary to prevent any change in the relative concentration of refrigerant components.

Before starting up the machine it is necessary to power the outer crankcase heaters (oil heater) for at least 6-8 hours. Ensure that the discharge and suction taps are open. Then start one compressor at a time (for multi compressor packs), supervising the relevant equipment (pressure-meter) and operating pressure on both the discharge side (compression) and on the return side (suction).

The figure below shows the running diagram for the safety pressure switches featured in each single compressor.

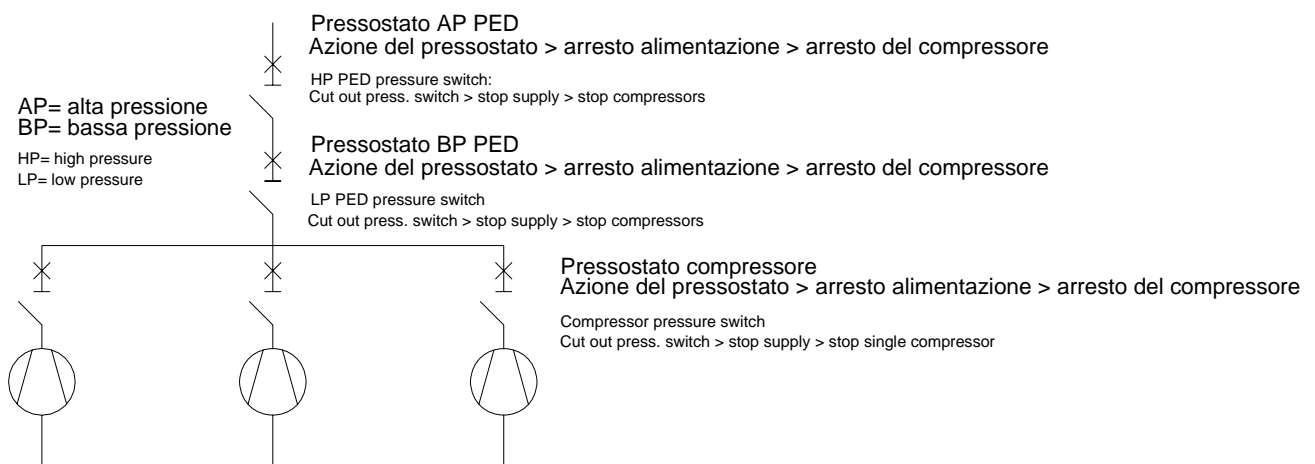

The action of pressure switches, with reference to the refrigerating diagrams in Chapter 2, can be summarized as follows:

- HP safety pressure switches: (HP PED pressure switch): when pressure rises above the calibration value downstream of the compressors, then these pressure switches trip, shutting down the power supply and consequently stopping all the compressors.
- BP safety high-pressure switch (LP PED pressure switch): when pressure drops below the calibration value following an excessive decrease in suction temperature, then this pressure switch trips, which shuts down the power supply and consequently stops all the compressors;

COSTAN TECHNICAL DOCUMENTATION		REVISION STATUS		TRUE COPY OF THE SIGNED ORIGINAL	PAGE 16 OF 18	
PRODUCT: EPTAGLOO		ORD	DATE		CHANGE ORDER	DATE OF 1st ISSUE
DOC. no. QSM0000406A CHAP. No.: 040		A	18.Dec.2008		UPDATE	13/June/07
CHAPTER: INSTALLATION		B	28.July.2009		UPDATE C	
		C	23.Feb.2010		RANGE EXTENSION	
		D	11.Nov..2010	SAFETY VALVE ADDED	ISSUED BY MKT	

- Compressor protecting pressure switch HP side: when pressure rises in an individual compressor then this pressure switch trips, which shuts down the power supply to that compressor and stops it immediately.

	Jobs requiring the electrical board to be live and open may be carried out only by qualified and expert personnel. When the electrical board is open and energized, this is visually signaled by an alarm/danger red intermittent light. The person in charge of these jobs must absolutely not leave the equipment when the safety devices provided by the manufacturer are disabled.
---	---

Check rotation of the remote condenser fans (the fans must expel air from the condenser battery). Then, if necessary, correct high pressure switch settings.

Top up with refrigerant through the suction line following the instructions above and modulating the amount of refrigerant.

Check the oil level in the oil reservoir and in each compressor (while the compressor is off). The oil level in the float regulator must reach 3/8 of the viewer, whereas in the oil reservoir it must be at the upper viewer after the system has run for a couple of days. If this is not the case, top up the initial charge until the required levels are reached, strictly following the above instructions. Do not add oil unless the oil level has dropped below the lower viewer's mid-line. **After a certain operation time (about 12 hours), or when a remarkable increase in leaks through the suction filters is detected, stop the plant. Shut both filters off and replace the filtering cartridges: place a mechanical filtering core (Castel 4495/C) in the suction filter and a dryer core (Castel 4490/C) in the liquid line filter using the supplies. Empty the pipe stretches involved and then restart the system. Check the oil level in the compressors and in the oil reservoir again.** The oil level in the reservoir must never reach below the lower viewer.

NOTE: If the oil reservoir should be replaced in a system that has already been commissioned, add oil very carefully. Top up again only after the system has worked for a whole day (which is enough for oil to get back to the oil reservoir). If the oil level does not reach the upper viewer, add the necessary amount. Conversely, if the oil level should exceed the upper viewer, it is indispensable to empty the excess through the bottom valve¹.

OVERCURRENT CIRCUIT BREAKERS

I.D.	SETTING
QM1	Current rating for compressor #1 (In)
QM2	Current rating for compressor #2 (In)
QM3	Current rating for compressor #3 (In)
QM4	Current rating for compressor #4 (In)

¹ As stated in Carly literature 13.3 (6/95)

COSTAN TECHNICAL DOCUMENTATION		REVISION STATUS			TRUE COPY OF THE SIGNED ORIGINAL	PAGE 17 OF 18
PRODUCT: EPTAGLOO		ORD	DATE	CHANGE ORDER		DATE OF 1st ISSUE 13/June/07
DOC. no. QSM0000406A CHAP. No.: 040		A	18.Dec.2008	UPDATE		
CHAPTER: INSTALLATION		B	28.July.2009	UPDATE C		
		C	23.Feb.2010	RANGE EXTENSION		
		D	11.Nov..2010	SAFETY VALVE ADDED	ISSUED BY MKT	

PRESSURE-SWITCH FOR THE CONTROL OF COMPRESSORS WHEN UNDER BACK-UP FUNCTIONING

Low pressure side		MT	LT
I.D.	FUNCTION	R404A bar ¹ (°C) ²	R404A bar (°C)
PSB ³ UTQ39040 - SHEET 4	COMPRESSOR SHUTDOWN (LOW-PRESSURE BACK-UP)	2,6 (-14)	0,5 (-37)
	DIFFERENTIAL	1,0	0,7

¹ Bar relative.

² The saturation temperature corresponding to calibration pressure is shown in brackets.

³ Low pressure switch KP1 , automatic-reset, adjustable-calibration type, for electromechanical operation in the event of controller failure (compressor cycling).

COSTAN TECHNICAL DOCUMENTATION		REVISION STATUS			TRUE COPY OF THE SIGNED ORIGINAL	PAGE 18 OF 18
PRODUCT: EPTAGLOO		ORD	DATE	CHANGE ORDER		DATE OF 1st ISSUE 13/June/07
DOC. no. QSM0000406A CHAP. No.: 040		A	18.Dec.2008	UPDATE		
CHAPTER: INSTALLATION		B	28.July.2009	UPDATE C		
		C	23.Feb.2010	RANGE EXTENSION		
		D	11.Nov..2010	SAFETY VALVE ADDED	ISSUED BY MKT	

PRESSURE SWITCHES FOR THE CONTROL OF CONDENSER FANS

(Only versions with controllers: Danfoss EKC331T / Carel IR32Z3 / Carel Micro Rack)

High pressure side		MT	LT
I.D.	FUNCTION	R404A bar (°C)	R404A bar (°C)
PV1 ¹ UTQ39080 -SHEET 8	START OF FAN #1	13,9 (+32,0)	13,9 (+32,0)
	DIFFERENTIAL	3,0	3,0
PV2 UTQ39080 -SHEET 8	START OF FAN #2	15,0 (+35,0)	15,0 (+35,0)
	DIFFERENTIAL	3,0	3,0
PV3 UTQ39080 SHEET 8	START OF FAN #3	16,3 (+38,0)	16,3 (+38,0)
	DIFFERENTIAL	3,0	3,0
PV4 UTQ39080 -SHEET 8	START OF FAN #4	17,0 (+40,0)	17,0 (+40,0)
	DIFFERENTIAL	3,0	3,0

PRESSURE-SWITCH FOR THE CONTROL OF CONDENSER FANS WHEN UNDER BACK-UP FUNCTIONING

(Only versions with controllers: Danfoss AK-PC530 / Carel PCO3)

High pressure side		MT	LT
I.D.	FUNCTION	R404A bar (°C)	R404A bar (°C)
PSA ² UTQ39040 -SHEET 4	CONDENSER FAN START	20,4 (+47,0)	20,4 (+47,0)
	DIFFERENTIAL	3,0	3,0

¹High pressure switch KP5, manual-reset, adjustable-setting, for backup mechanical operation in the event of controller failure (condenser fan control).

²High pressure switch KP5, manual-reset, adjustable-setting, for backup mechanical operation in the event of controller failure (condenser fan control).

COSTAN TECHNICAL DOCUMENTATION		REVISION STATUS		TRUE COPY OF THE SIGNED ORIGINAL	PAGE 19 OF 18	
PRODUCT: EPTAGLOO		ORD	DATE		CHANGE ORDER	DATE OF 1st ISSUE 13/June/07
DOC. no. QSM0000406A CHAP. No.: 040		A	18.Dec.2008		UPDATE	
CHAPTER: INSTALLATION		B	28.July.2009		UPDATE C	
		C	23.Feb.2010		RANGE EXTENSION	
		D	11.Nov..2010	SAFETY VALVE ADDED	ISSUED BY MKT	

PED-COMPLIANT SAFETY PRESSURE SWITCHES

High pressure side		MT	LT
I.D.	FUNCTION	R404A bar (°C)	R404A bar (°C)
PLP ¹ UTQ39030 -SHEET 3	SYSTEM PROTECTION	1,5 (-25)	0 (-46)
	DIFFERENTIAL	1,0	0,7

PED-COMPLIANT SAFETY PRESSURE SWITCHES

High pressure side		MT	LT
I.D.	FUNCTION	R404A bar (°C)	R404A bar (°C)
PHP-1 ² UTQ39030 -SHEET 3	SYSTEM PROTECTION	27 (+59)	27 (+59)
	DIFFERENTIAL	fixed 4,0	fixed 4,0
PHP-2 ³ UTQ39030 -SHEET 3	SYSTEM PROTECTION	28 (+60,6)	28 (+60,6)
	DIFFERENTIAL	fixed 4,0	fixed 4,0
PHP-C ⁴ UTQ39070 - SHEET 3	COMPRESSOR PROTECTION	26,5 (+58,1)	26,5 (+58,1)
	DIFFERENTIAL	6,0	6,0

¹System-protection low-pressure switch KP1, automatic-reset, adjustable-setting.

²High-pressure switch KP7B, manual reset type for system protection (factory-calibrated at Costan's)

³System protection high pressure switch KP7S, manual-reset type (calibrated at Costan's).

⁴High pressure switch KP5, manual-reset type, for compressor protection (one for each compressor, factory-calibrated at Costan's).

COSTAN TECHNICAL DOCUMENTATION		REVISION STATUS			TRUE COPY OF THE SIGNED ORIGINAL	PAGE 20 OF 18
PRODUCT: EPTAGLOO		ORD	DATE	CHANGE ORDER		DATE OF 1st ISSUE 13/June/07
DOC. no. QSM0000406A CHAP. No.: 040		A	18.Dec.2008	UPDATE		
CHAPTER: INSTALLATION		B	28.July.2009	UPDATE C		
		C	23.Feb.2010	RANGE EXTENSION		
		D	11.Nov..2010	SAFETY VALVE ADDED	ISSUED BY MKT	

DELAY DEVICES

DESCRIPTION	I.D.	TIME (MIN)
LIQUID LEVEL (if any)	RLL	30
ACTUATION OF EMERGENCY BACK-UP REGULATION	R0	40-50
BACK-UP CUT-IN FOR COMPRESSOR #1	R1	1
BACK-UP CUT-IN FOR COMPRESSOR #2	R2	2
BACK-UP CUT-IN FOR COMPRESSOR #3	R3	3



COMMISSIONING AND ON-SITE TESTING ADVICE 1. All the settings in these tables must be verified. 2. All pressure switches and delay devices must be tested and test-operated. 3. Pressure switches are factory-calibrated by Quality Control Dept. following procedure OP00144Q. They must be attached an I.D. label including calibration values and date, as well as the ID of the person who performed the calibration. Their lead seal must be intact. When test-run as per operational instruction QOP019110A, correct tripping of safety pressure-switches was simulated and verified

COSTAN TECHNICAL DOCUMENTATION		REVISION STATUS		TRUE COPY	PAGE 21 OF 18
PRODUCT: EPTAGLOO		ORD	DATE	CHANGE ORDER	OF THE SIGNED ORIGINAL
DOC. no. QSM0000406A CHAP. No.: 040		A	18.Dec.2008	UPDATE	DATE OF 1st ISSUE 13/June/07
CHAPTER: INSTALLATION		B	28.July.2009	UPDATE C	
		C	23.Feb.2010	RANGE EXTENSION	
		D	11.Nov..2010	SAFETY VALVE ADDED	ISSUED BY MKT

Actuation diagram for safety electronic and electromechanical devices – MT application using R404A.

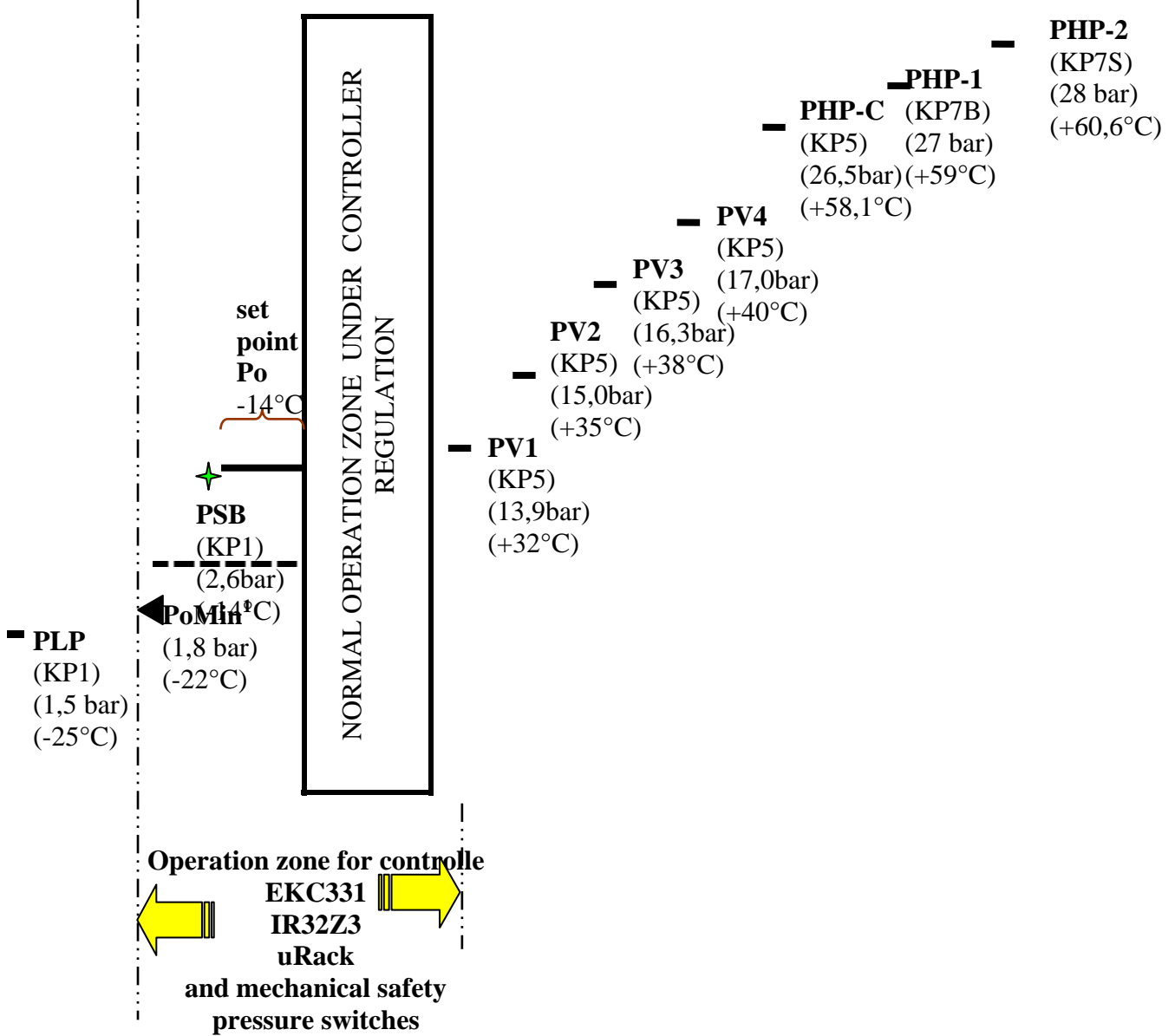

¹ Controller parameter to be configured as explained in the “REGULATION” section of the Use and Maintenance manual.

✦ stands for the tripping point of mechanical backup pressure switches

COSTAN TECHNICAL DOCUMENTATION	REVISION STATUS		TRUE COPY	PAGE 22 OF 18
PRODUCT: EPTAGLOO	ORD	DATE	CHANGE ORDER	OF THE SIGNED ORIGINAL
DOC. no. QSM0000406A	A	18.Dec.2008	UPDATE	DATE OF 1st ISSUE 13/June/07
CHAP. No.: 040	B	28.July.2009	UPDATE C	
CHAPTER: INSTALLATION	C	23.Feb.2010	RANGE EXTENSION	
	D	11.Nov..2010	SAFETY VALVE ADDED	ISSUED BY MKT

Actuation diagram for safety electronic and electromechanical devices – MT application using R404A.

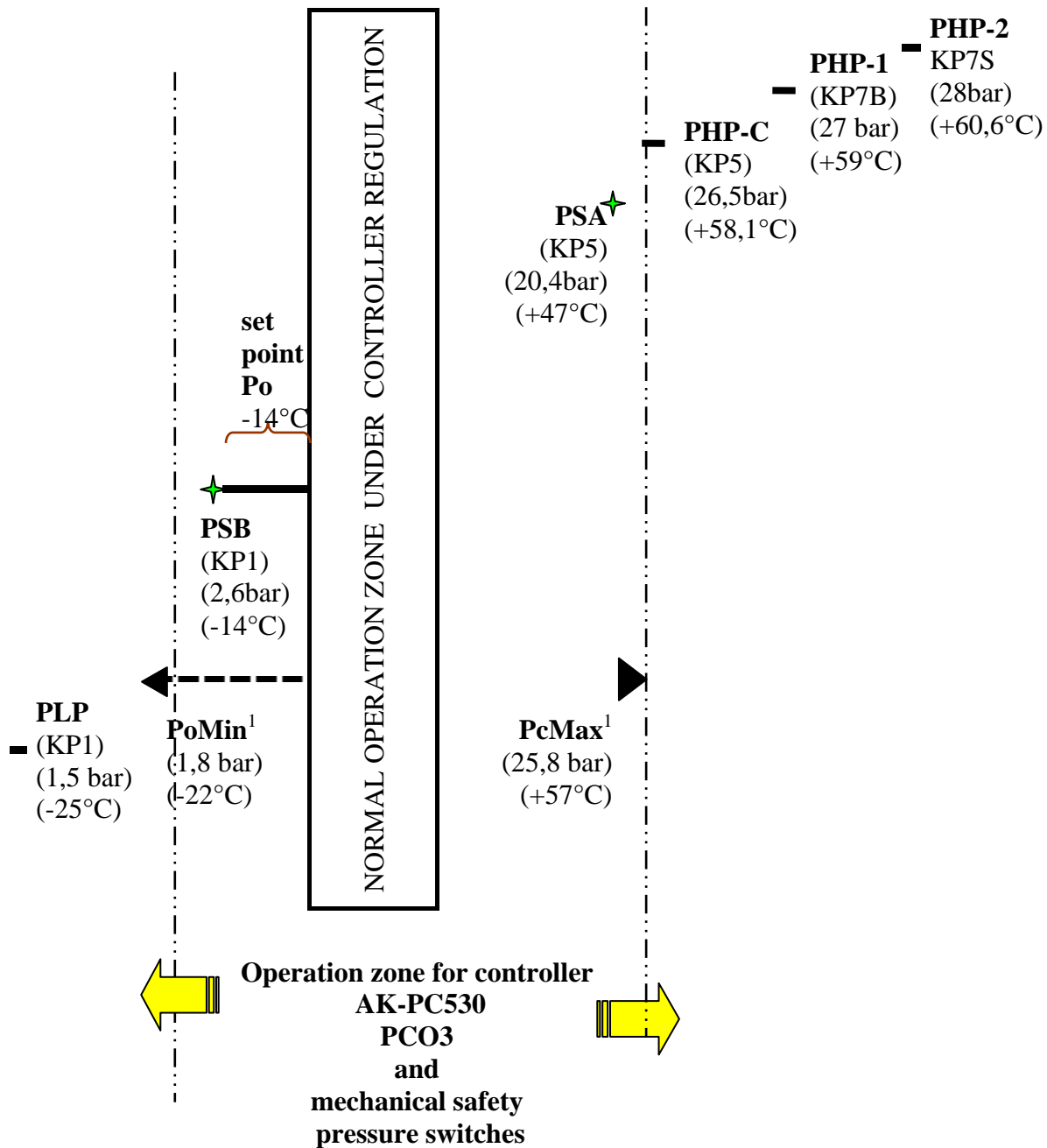

¹ Controller parameter to be configured as explained in the “REGULATION” section of the Use and Maintenance manual.

★ stands for the tripping point of mechanical backup pressure switches

COSTAN TECHNICAL DOCUMENTATION		REVISION STATUS		TRUE COPY OF THE SIGNED ORIGINAL	PAGE 23 OF 18	
PRODUCT: EPTAGLOO		ORD	DATE		CHANGE ORDER	DATE OF 1st ISSUE 13/June/07
DOC. no. QSM0000406A	CHAP. No.: 040	A	18.Dec.2008		UPDATE	
CHAPTER: INSTALLATION		B	28.July.2009		UPDATE C	
		C	23.Feb.2010	RANGE EXTENSION		
		D	11.Nov..2010	SAFETY VALVE ADDED	ISSUED BY MKT	

Actuation diagram for safety electronic and electromechanical devices – LT applications using R404A.

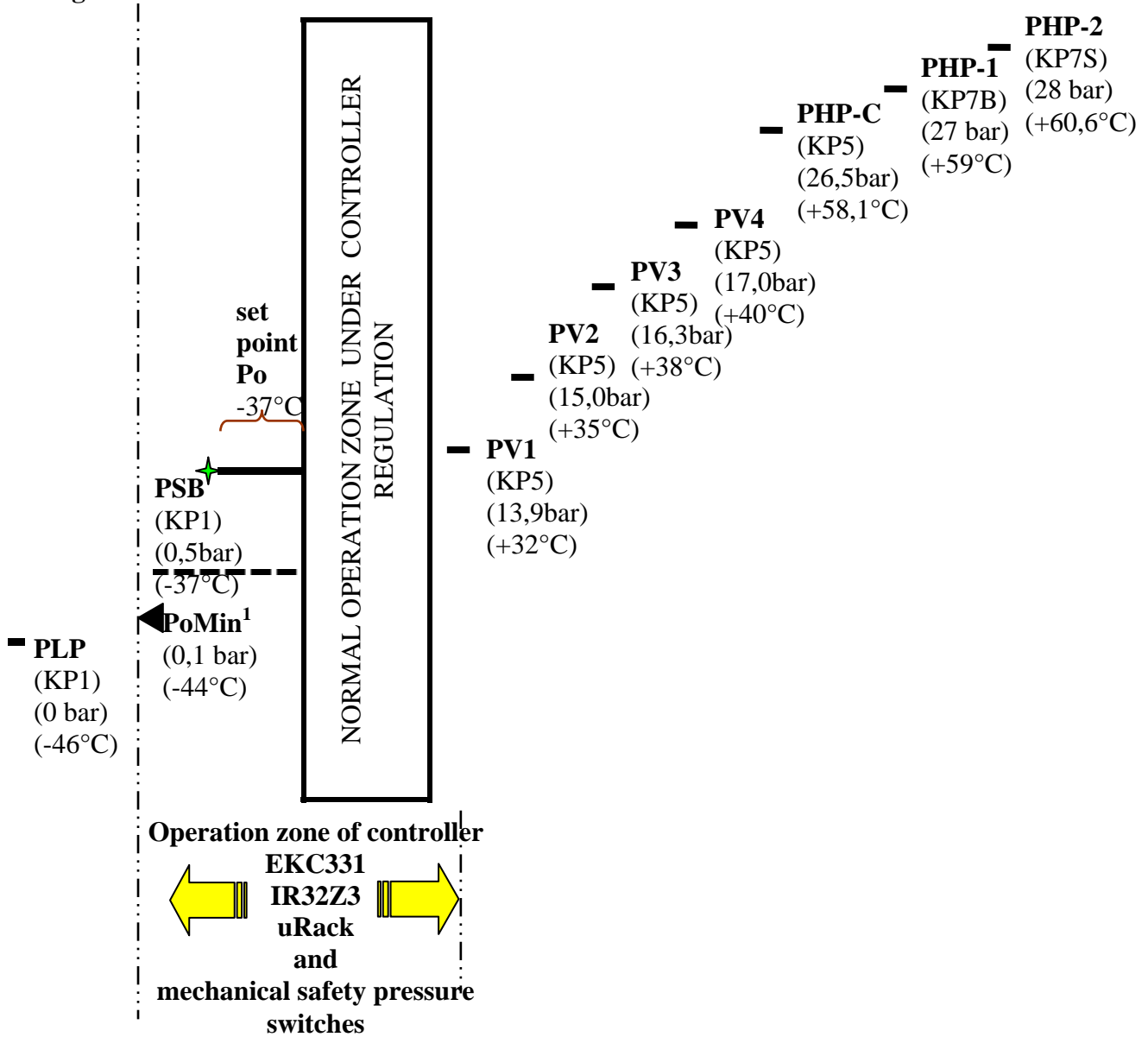

¹ Controller parameter to be configured as explained in the “REGULATION” section of the Use and Maintenance manual.

✦ stands for the tripping point of mechanical backup pressure switches

COSTAN TECHNICAL DOCUMENTATION PRODUCT: EPTAGLOO DOC. no. QSM0000406A CHAP. No.: 040 CHAPTER: INSTALLATION	REVISION STATUS		TRUE COPY OF THE SIGNED ORIGINAL	PAGE 24 OF 18	
	ORD	DATE		CHANGE ORDER	DATE OF 1st ISSUE 13/June/07
	A	18.Dec.2008		UPDATE	
	B	28.July.2009		UPDATE C	
	C	23.Feb.2010		RANGE EXTENSION	
D	11.Nov..2010	SAFETY VALVE ADDED	ISSUED BY MKT		

Actuation diagram for safety electronic and electromechanical devices – BT applications using R404A.

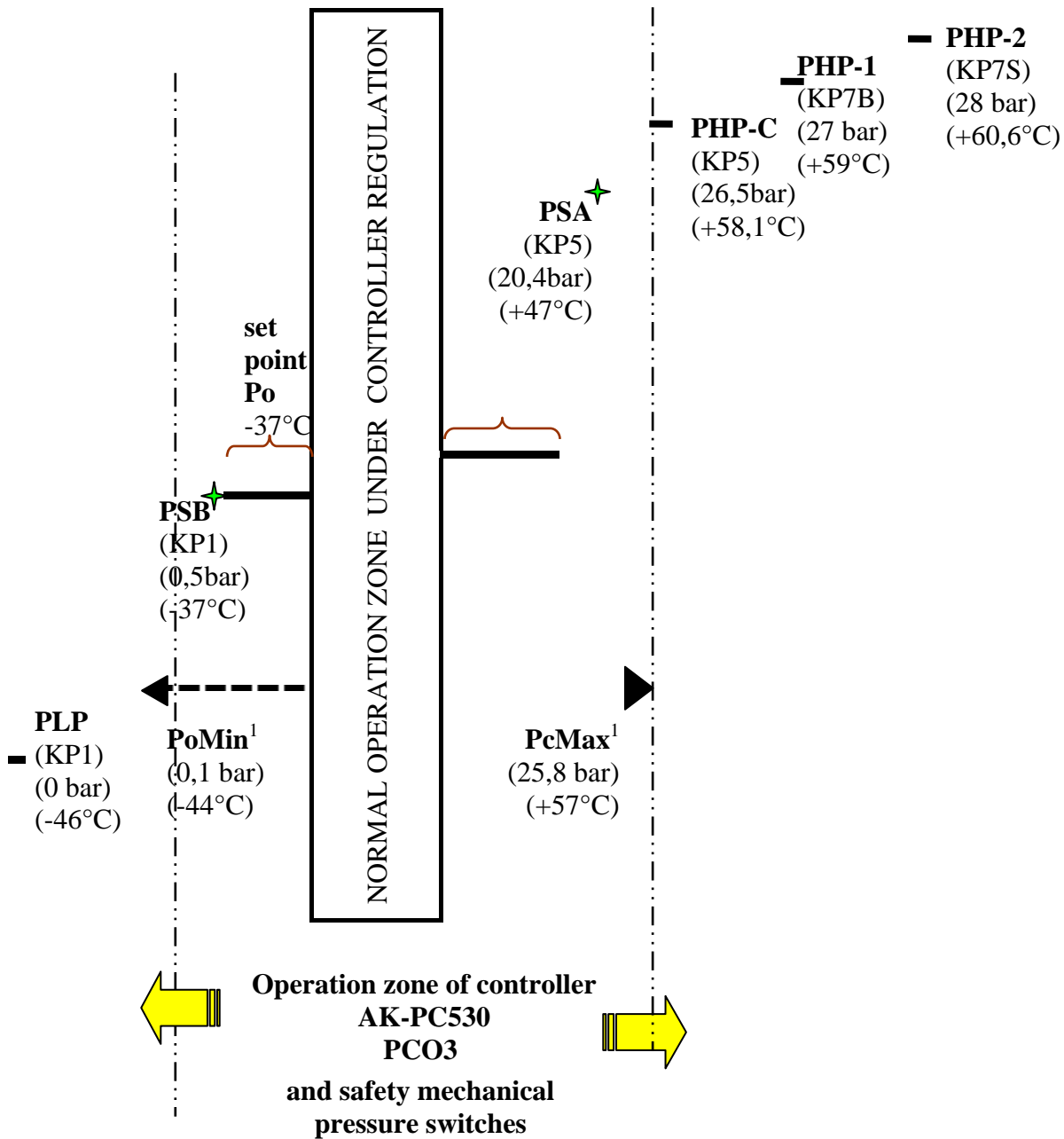

¹ Controller parameter to be configured as explained in the “Control and Regulation” section of the Use and Maintenance manual.

✦ stands for the tripping point of mechanical backup pressure switches

COSTAN TECHNICAL DOCUMENTATION		REVISION STATUS		TRUE COPY OF THE SIGNED ORIGINAL	PAGE 7 OF 8
PRODUCT: EPTAGLOO		ORD	DATE		CHANGE ORDER
DOC. no. QSM0000406A CHAP. No.: 050		A	23.Feb.2010	RANGE EXTENSION	13/June/07
CHAPTER: ELECTRICAL PANEL					
TECHNICAL SPECS					ISSUED BY MKT

050 - ELECTRICAL PANEL TECHNICAL SPECIFICATIONS

1. Overview.

1.1 On-board electrical panel for the control of 3/4 compressors and 3/4 condenser fans.

2. Reference standards

- 2.1 **EN 60204-1** in force (Electrical equipment of machines)
 2.2 **EN 60439-1** in force (Low-voltage switchgear)

3. Power supply and operating voltage

- 3.1 **380V-400V/3Ph/50-60Hz**
 3.2 **220V-230V/3Ph/50-60Hz**
 3.3 As for 230V auxiliary voltage adjustment, cfr. chap.6.
 3.4 Observe the position of the wiring inlet

For equipment to be installed indoors, cables must enter the board from above, through a hole drilled on the appropriate plate, which is located above the master switch. For equipment to be installed outdoors, it is advisable to have cables enter from below, through a hole drilled on the appropriate plate, and then lead them to the master switch in the proper raceway.

For the purposes of maintaining the electrical panel's protection rating it is necessary to use the appropriate wire bushing.

Short-circuit hazard: when drilling the hole through which the wiring is going to run, it is necessary to exercise maximum caution and prevent metal chips from entering the electrical panel.

3.5 Power wires must be directly connected to terminals L1-L2-L3 of the master switch, observing the cyclic direction of phases.

**The earthing wire must be connected to the earthing terminal marked PE.
 Connect this and then the phases.**

4. Master circuit breaker and power distribution: Diagram UTQ39010/sheet 1.

- 4.1 General circuit breaker with fuses: ABB series OS from 32A up to 250A including terminal-covering caps.
 4.2 Yellow-red handle that can be padlocked (for emergency purposes) assembled onto the door.

When servicing the equipment the circuit breaker must be OFF

5. Distribution.

- 5.1 Bus bar feeder system SIEMENS SIRIUS 3R, distance between bar centers 60mm.
 5.2 Overcurrent switches on compressors and fans are connected to the contactors by way of accessories that afford safe current transmission.
 5.3. The overcurrent switch/contactator set is fastened to a suitable plate that can be fitted onto the bars by spring terminals, thus ensuring secure electrical transmission.

6. Auxiliary circuit

- 6.1.1 **Power supply and operating voltage 230V/50-60Hz. / Diagram #UTQ39020/sheet 2.**
 6.1.2 **230V** auxiliary voltage from transformer LEGRAND 230V-400V/230V.

COSTAN TECHNICAL DOCUMENTATION		REVISION STATUS		TRUE COPY OF THE SIGNED ORIGINAL	PAGE 8 OF 8	
PRODUCT: EPTAGLOO		ORD	DATE		CHANGE ORDER	DATE OF 1st ISSUE 13/June/07
DOC. no. QSM0000406A	CHAP. No.: 050	A	23.Feb.2010		RANGE EXTENSION	
CHAPTER: ELECTRICAL PANEL TECHNICAL SPECS						ISSUED BY MKT

C34C-3compressori : mod. **044266** (400VA) / C34C-4 compressors :mod. **044267** (630VA).

The electrical panel was mounted on the machine in accordance with the power voltage requested at the time of ordering. Before powering up the machine, verify that the auxiliary transformer's primary voltage setting is consistent with the equipment's voltage (400V or 230V) and ensure that the transformer's secondary output is **230V** . Transformer output voltage can be adjusted by **+/-15V**: for effective **230V** output, adjusting the transformer's secondary is capital.

Adjustment is dependent on the voltage supplied by the Electricity Company.

The transformer is delivered ready for operation on 400V/50-60Hz.

6.3 **Red** color wires.

6.4 Cable numbering as per diagram.

6.5 Line start fuses for auxiliary circuits with 5x20 fuses (250Vac).

6.6 Timers: FINDER 80.11

6.7 Auxiliary relays: FINDER 55.34

6.8 Warning lights: SIEMENS SB3 diameter 22.

6.9 of Auxiliary circuit distribution 230V through shielded LEGRAND bars art. 004880 / 004881.

6.10 **PED Directive-compliant safety general low-pressure and high pressure switches. Diagram UTQ039030/sheet 3.**

6.10.1 System shutdown in case of low pressure emergency by pressure-switch KLP (Danfoss KP1).

6.10.2 System shutdown in case of high pressure emergency by pressure-switches KHP1 (Danfoss KP7B) and KHP2 (Danfoss KP7S). These pressure-switches are pre-set at the factory and need to be re-engaged manually after they have tripped and after the cause of the fault has been removed.

6.11 **Emergency back-up regulation: Diagram UTQ039040/sheet 4**

Mechanical back-up operation in case of failure of the high and low pressure electronic control.

6.11.1 *Low pressure mechanical back-up.*

Performed by pressure switch PSB (Danfoss KP1) and delay devices R0-1-2-3.

Operation: In the event that the electronic controller fails, all compressors are shutdown. If the off time is shorter than the time set for timer R0 (40-50 min.) then safety pressure switch PSB trips and delay timer R1 starts to count. This starts compressor n°.1 and actuates delay devices R2/3 which are associated to the compressors to be started next. Compressors under backup operation are controlled through pressure switch PSB and the delay devices. PSB must be set to an average operating value, thereby avoiding any possible interference with safety low pressure switch KLP (Danfoss KP1).

The compressors to come on when under back-up functioning are all but one (-1). This means that one compressor is excluded from back-up operation.

6.11.2 *High pressure mechanical back-up.* (only featured with high-pressure electronic controller)

COSTAN TECHNICAL DOCUMENTATION	REVISION STATUS			TRUE COPY	PAGE 9 OF 8
PRODUCT: EPTAGLOO	ORD	DATE	CHANGE ORDER	OF THE SIGNED ORIGINAL	DATE OF 1st ISSUE
DOC. no. QSM0000406A CHAP. No.: 050	A	23.Feb.2010	RANGE EXTENSION		13/June/07
CHAPTER: ELECTRICAL PANEL					ISSUED BY MKT
TECHNICAL SPECS					

This is provided only when high pressure is controlled by the electronic regulator. This is performed by safety pressure switch PSA (Danfoss KP2).

Operation: upon reaching its actuation threshold, pressure switch PSA turns all condenser fans on. Its setting must be above the electronic processor's threshold, but below the high pressure value set for back up pressure switches KHP1/2, as per PED Directive (Danfoss KP7B/S). PSA differential must be set to a value that may allow condenser cooling.

Back-up regulation, low-pressure especially, is an emergency condition that does not optimize compressor and pressure management. Therefore regulation by the electronic control must be restored as soon as possible.

6.12 Alarms: Diagram UTQ39050/sheet 5.

6.12.1 Red alarm warning lamps on the front of the electrical panel.

6.12.2 Remote transmission by clean contacts on the terminal board: Alarm contacts are closed when on and open when in alarm status.

6.12.3 **Only clean contacts and voltage below 50V can be led to the alarm terminal strip and respective contacts.**

For details on alarm signals, cfr. chapter 15 - Warning lamps .

6.13 Liquid level and general liquid injection: Diagram UTQ39060/sheet 6.

6.13.1 **The refrigerant liquid level undergoes monitoring; alarm signaling is delayed by a timer.**

6.13.2 Liquid injection for low temperature units. Control of general liquid-injecting valve through auxiliary contacts in parallel with all the compressors.

7. Compressor circuit: Diagram #UTQ39070/sheet 7.

7.1 Compact system SIEMENS SIRIUS S0/2

7.1.1 Overcurrent switch (Overload cutout) and circuit breaker that can be padlocked when compressors are under maintenance (Siemens series S0/2)

7.1.2 Electrical panel versions with residual current device **Merlin Gerin RH99M** and associated **Toroid TA30** operate the overcurrent circuit breaker (overload cutout) by way of a release coil that ensures AC23 maneuvers and cuts off the electrical circuit.

7.1.3 Contactors: Siemens series S0/2, coordinated with their respective overcurrent device following the tables supplied by SIEMENS

7.1.4 compressors are protected by overcurrent cutout switches performing the following functions:

- protection against short-circuit
- protection against overcurrent
- protection against phase loss
- protection against phase displacement: this trips when current input differs by 30%-50% between phases.

7.1.5 Low oil level protection circuit. by pressure switch or oil electronic detector.

7.1.6 Overheating protection circuit monitored by thermistor probes connected to probe monitor KRIWAN INT69VS / SE-BE according to DIN 44081 standards.

7.1.7 Maneuvers and life of contactors

COSTAN TECHNICAL DOCUMENTATION	REVISION STATUS			TRUE COPY	PAGE 10 OF 8
PRODUCT: EPTAGLOO	ORD	DATE	CHANGE ORDER	OF THE SIGNED ORIGINAL	DATE OF 1st ISSUE
DOC. no. QSM0000406A CHAP. No.: 050	A	23.Feb.2010	RANGE EXTENSION		13/June/07
CHAPTER: ELECTRICAL PANEL					
TECHNICAL SPECS					ISSUED BY MKT

Motor contactors have been designed for a million maneuvers on average (1 maneuver = 1on+1off) with the maximum rated current in category AC3. Considering that the limit of an average compressor is 10-12 starts per hour, the useful life of a contactor will be **10** years if their starts occur under the severest conditions (continuous breakaway - maximum compressor load - rated current). Also considering that in systems including several compressors, these are made turn over by the electronic controller, that under normal operation conditions electric motors are used by 50-40% of their rated nominal current and considering also that systems have dead zone periods (in which systems are stable and compressors are not required to go on or off), contactor life must necessarily be longer than the length they were designed for.

(Details on contactor life taken from catalogue SIEMENS SIRIUS 3R).

It is worth underlining and bearing in mind that in our case, the life of a contactor is **not** determined by the number of maneuvers it performs (which, considering the amperage rating in category AC3 may total 250 maneuvers/hour), but by the compressor: for small/medium compressors max. 10-15 maneuvers/hour; large compressors: max. 6-7 maneuvers/hour. Exceeding the compressor maneuvers/hour physical limit may damage the equipment itself and even cause short circuit in the electric motor.

Short circuit is prevented by the overcurrent device protecting the compressor.

After a short-circuit has occurred, both the overcurrent cutout and the contactor will have to be replaced.

(cfr. chapter 23 “important notice”).

8. Condenser fan circuit Diagram UTQ39080/sheet 8.

8.1 Compact system SIEMENS SIRIUS S0.

8.1.1 For electrical panels with overcurrent protection: fan protection by fuse-fitted circuit breakers 10,3X38 and the relevant aM fuses.

8.1.2 For optional electrical panels with RCBO (residual current+overcurrent protection): overcurrent cutout Siemens Sirius series S0 with release coil actuated by residual current device **Merlin Gerin RH99M+tore 30**.

8.1.3 Contactor SIEMENS S00/0.

8.2 The power circuit for the fan must be wired up strictly following the phase sequence L1-L2-L3.

9. Control circuit to operate the machine-cooling fans and the plant-room air expeller: Diagram #UTQ39090/sheet 9.

9.1 Fuses for machine-cooling fans (if any)

9.2 Fuses for the power board: plant-room air-expellers.

10. Control electronics diagram #UTQ039E_0/sheet 10/E.

10.1 Controllers

10.1.1 Box under Costan code **UQ39E001E** wired to **DANFOSS EKC331/T**

Low-pressure electronic regulation by the dead zone principle. High pressure regulation by pressure-switches.

10.1.2 box under Costan code **UQ39E002E** wired to **CAREL IR32Z3**

Low-pressure regulation by electronic pressure-switch and the stepper principle. High pressure regulation by pressure-switches.

10.1.3 Box under Costan code **UQ39E003E** wired to **DANFOSS AK-PC530**

Low and high pressure electronic regulation by the dead zone principle.

COSTAN TECHNICAL DOCUMENTATION		REVISION STATUS		TRUE COPY OF THE SIGNED ORIGINAL	PAGE 11 OF 8
PRODUCT: EPTAGLOO		ORD	DATE		CHANGE ORDER
DOC. no. QSM0000406A CHAP. No.: 050		A	23.Feb.2010	RANGE EXTENSION	13/June/07
CHAPTER: ELECTRICAL PANEL					
TECHNICAL SPECS					ISSUED BY MKT

10.1.4 box under Costan code **3N5650** wired to **CAREL PCO-3 BUILT-IN MEDIUM PCO3CF051K**

Low and high pressure electronic regulation by the dead zone principle.

10.1.5 box under Costan code **UQ39E005E** wired to **CAREL uRack (micro Rack)**

Low-pressure electronic regulation by the dead zone principle.

10.2 Controller wiring

10.2.1 Controllers are wired in an appropriate box that can be removed by unscrewing the bolts that fasten it and disconnecting the clamp plugs.

As for controller features, cfr. the Control and Regulation chapter.

11. OPTIONAL residual current circuit protection against indirect contact:

Diagrams UTQ039110/sheet 11 - UTQ039112/sheet 12 - UTQ039113/sheet 13.

11.1 Diagram UTQ039110/sheet 11 n.2 residual current devices for overall safety and service

11.1.1 residual current device n.1 protects the PED pressure-switch circuits and back-up operation regulation

11.1.2 residual current device n.2 protects secondary auxiliary circuits, liquid level, alarm and the electronic regulation box.

The two residual current devices never shut down the machine due to failure of secondary services.

11.2 Diagram #UTQ039120/sheet 12 residual current devices for compressor protection

Each compressor has a residual current device, so that when one compressor fails this does not affect the others.

11.3 Diagram #UTQ039130/sheet 12 residual current devices to protect condenser fans

Each condenser fan control has a residual current device, which means that when one fan control circuit fails it does not affect the others.

**The setting for residual current devices must not be below a current of ID of 300mA.
Tripping time must not be below 150mS.
Residual current devices must be test operated regularly, using the appropriate push-button.**

12. Terminal strips

12.1 Phoenix spring terminals organized in terminal strips as below:

12.2 **Terminal strip 1: machine compressor connection:** horizontal lower position.

12.1 This terminal strip is where all auxiliary, control and compressor mechanisms are connected.

These devices are factory-wired.

12.3 **Terminal strip 2: Condenser fans and machine-room air expeller:** side/vertical position. Connections to be made on site.

12.2.1 This terminal strip is where all machine external services and accessories are connected, i.e condenser fans, machine room air expeller and alarms. These accessories need to be connected on site.

12.2.2 To lead the wires in use the appropriate raceway on the right side of the electrical panel.

12.2.3 All the mechanisms must be connected to the earthing system using the appropriate earthing bar.

12.4 **Terminal strip 2: Alarms:** side/vertical position. Connections to be made on site.

COSTAN TECHNICAL DOCUMENTATION		REVISION STATUS		TRUE COPY	PAGE 12 OF 8
PRODUCT: EPTAGLOO		ORD	DATE	OF THE SIGNED	DATE OF 1st ISSUE
DOC. no. QSM0000406A	CHAP. No.: 050	A	23.Feb.2010	ORIGINAL	13/June/07
CHAPTER: ELECTRICAL PANEL					
TECHNICAL SPECS					ISSUED BY MKT

12.4.1 the contacts in the alarm terminal strip for remote-transmission must be cold (clean)

12.4.2 **Do not lead voltage above 50V to the alarm terminal strip.**

12.5 **Terminal strip 3 (fast-connection): Connection of regulation box:** top left/horizontal.

12.5.1 to replace the regulation box remove the clamp connectors (ensure that the electrical panel is off) and unscrew the box-fastening bolts.

13. Wiring.

13.1 Wiring as per reference EN-IEC standards.

13.2 All wires are flame-proof type.

13.3 The electrical panel was designed for an estimated internal temperature of 50°C.

14. Earthing connections.

14.1 The bottom plate, door and all other metal parts are connected to the earthing system.

14.2 Each terminal strip is fitted with two adequate-diameter copper bars for earthing connection.

14.3 To connect mechanisms to the earthing system on-site (condenser fans, machine-room expeller etc..) use the earthing bar under the vertical terminal strip.

15. Warning lamps

15.1 Warning lamps are diameter d=22, ingress protection rating IP65.

15.2 Bulbs are 230V neon-type.

15.3 Warning lamp color: alarm = red

On = white

15.4 each lamp is marked as in the wiring diagram; a plate with the inscription indicating the relevant function is at the top front.

15.6 Detail of warning lamps

Type	color	I.D.	name	function
On/status	white	H230	Voltage	The auxiliary circuit is hot. This warning lamp must be ON at all times.
Alarm	red	HLP	Low pressure	Low-pressure alarm on the general circuit. The entire system is shut down.
Alarm	red	HHP	High pressure	High-pressure alarm on the general circuit Pressure switches KP7B / KP7S have tripped.
Alarm	red	HLL	Liquid level	Low refrigerant liquid level in the circuit.
Alarm	red	H3	Back-up regulation	Electromechanical back-up control following failure of electronic control.
Alarm	red	HAC	Compressors	General compressor alarm due to the tripping of: overcurrent device, thermistor probes (Kriwan), compressor high-pressure switch, oil-level pressure switch or detector.
Alarm	red	HEC	Controller	On the controller box front. To be used in case the controller has an external alarm signaling contact. Is actuated in the event of controller alarm of any kind.

COSTAN TECHNICAL DOCUMENTATION	REVISION STATUS			TRUE COPY	PAGE 13 OF 8
PRODUCT: EPTAGLOO	ORD	DATE	CHANGE ORDER	OF THE SIGNED ORIGINAL	DATE OF 1st ISSUE
DOC. no. QSM0000406A CHAP. No.: 050	A	23.Feb.2010	RANGE EXTENSION		13/June/07
CHAPTER: ELECTRICAL PANEL					
TECHNICAL SPECS					ISSUED BY MKT

16. Lay-out / description of components / pre-holes.

16.1 The component lay-out is determined by ergonomic principles, with the power section separated from the regulation section.

17. Cooling of electrical panel

17.1 For models with overcurrent devices only, the electrical panel is cooled statically through an opening with a grid guard.

17.2 Models including residual current devices are fitted with a 16W fan Lume art. 17710 with grid and filter.

The air filter must be replaced regularly according to the dustiness in the installation site.

18. Component brands / models

18.1 Invariable components: as listed in the key to the wiring diagrams.

18.2 Variable components, size as per Costan table (QE-C34C-03-2006.xls).

19. Accessories supplied.

19.1 Handle for the replacement of general fuses.

19.2 Spare fuses: n.1 per type supplied in a cellophane envelope.

20. Inspection and testing.

20.1 The equipment undergoes electrical testing before delivery, including all the tests prescribed by the reference standards: **IEC-EN 60439-1 and IEC-EN 60204-1.**

21. Attached documents and certifications.

21.1 Wiring diagrams including relevant acronym key.

21.2 Declaration that the equipment complies with the relevant standards.

21.3 Equipment manual

21.4 All the documents above are attached to the equipment and delivered in the relevant document compartment.

22. Danger signs

22.1 “Caution voltage” triangle, black thunderbolt on yellow background near the master switch handle.

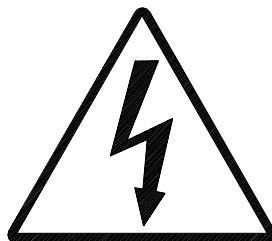

22.2 Manufacturer sticker identifying the electrical panel, down in the right corner inside the panel. It contains the name of the manufacturer, the electrical panel code, the serial number and manufacturing date. When reporting failure to Costan Quality Department, all these details must be provided.

COSTAN TECHNICAL DOCUMENTATION	REVISION STATUS			TRUE COPY	PAGE 14 OF 8
PRODUCT: EPTAGLOO	ORD	DATE	CHANGE ORDER	OF THE SIGNED ORIGINAL	DATE OF 1st ISSUE
DOC. no. QSM0000406A CHAP. No.: 050	A	23.Feb.2010	RANGE EXTENSION		13/June/07
CHAPTER: ELECTRICAL PANEL					ISSUED BY MKT
TECHNICAL SPECS					

23 Important warning

Breaking capacity of electrical panel

The circuit-breaking capacity (Icu) of the electrical panel is 50kA.

This information must be carefully considered when installing the equipment.
(Icu=rated ultimate circuit-breaking capacity).

Coordinating power equipment

The devices protecting compressors (overcurrent cutout-contactor) and condenser fans (overcurrent circuit-breaker and contactor) must be coordinated according to standards DIN VDE 0660, part 102/IEC947-4-1.

Coordination can be of two types: type one and type two. Costan electrical panels are designed for coordination **type 1** (one): **this means that the overcurrent cutout and relevant contactor must be replaced after short circuit has occurred downstream from the contactor (e.g. winding of compressor electric motor).**

COSTAN TECHNICAL DOCUMENTATION	REVISION STATUS			TRUE COPY	PAGE 7 OF 1
PRODUCT: EPTAGLOO	ORD	DATE	CHANGE ORDER	OF THE SIGNED ORIGINAL	DATE OF 1st ISSUE
DOC. no. QSM0000406A	A				13/June/07
CHAP. No.: 060	B				
CHAPTER: WIRING DIAGRAMS	C				ISSUED BY MKT

060 - WIRING DIAGRAMS

List of diagrams attached to the manual, as being an integral part thereof.

Standard electrical panel

Function	Diagram n°	Sheet
Master switch power	UTQ39010	1
Auxiliary transformers	UTQ39020	2
PED-compliant pressure-switches	UTQ39030	3
Mechanical back-up regulation	UTQ39040	4
Alarms	UTQ39050	5
Auxiliary services	UTQ39060	6
Control of compressors	UTQ39070	7
Control of condenser fans	UTQ39080	8
Machine-cooling fans	UTQ39090	9

Electrical panel option with RCDs (residual current device)

Function	Diagram n°	Sheet
Auxiliary transformers	UTQ39220	2
General RCD	UTQ39110	11
Compressor RCDs	UTQ39120	12
Condenser fan RCDs	UTQ39130	13
Settings for RCDs	TA-dI	14

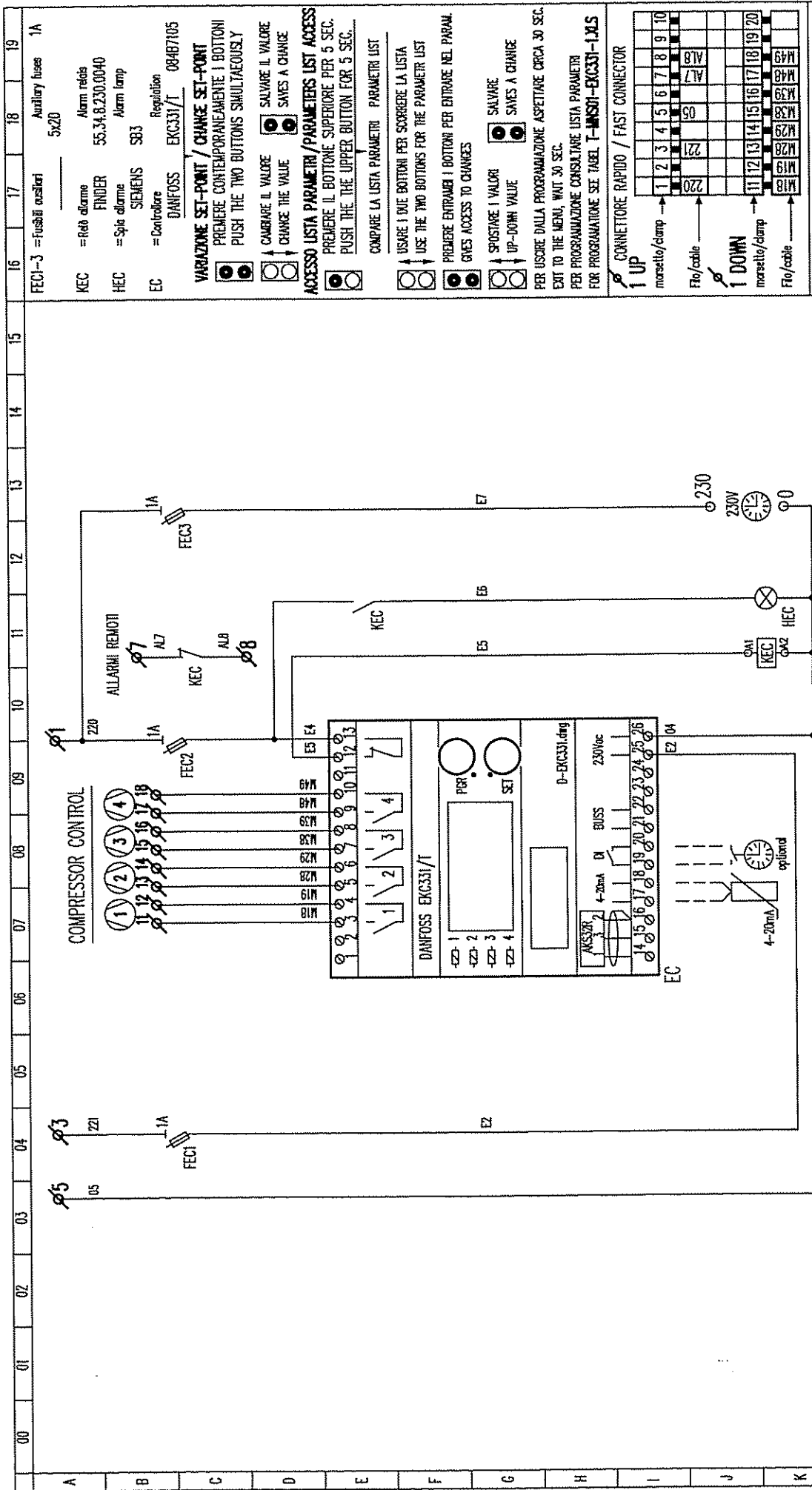

FEC1-3 = Fusibili ausiliari 5x20
Auxiliary fuses 1A

KEC =Relè allarme
Alarm relè
 FINJER 55.34.8.230.0040

HEC =Spile allarme
Alarm lamp
 SIEMENS SB3

EC =Controllore
Regulation
 DANFOSS EKC331/T 084B7105

VARIAZIONE SET-POINT / CHANGE SET-POINT
 PREMERE CONTEMPORANEAMENTE I BOTTONI
PUSH THE TWO BUTTONS SIMULTAEOUSLY

CAMBIARE IL VALORE / CHANGE THE VALUE
 SALVARE IL VALORE / SAVED A CHANGE
SAVE A CHANGE

ACCESSO LISTA PARAMETRI / PARAMETERS LIST ACCESS
 PREMERE IL BOTTONE SUPERIORE PER 5 SEC.
PUSH THE UPPER BUTTON FOR 5 SEC.

COMPARE LA LISTA PARAMETRI / PARAMETERS LIST
 USARE I DUE BOTTONI PER SCORRERE LA LISTA
USE THE TWO BUTTONS FOR THE PARAMETR LIST

**PREMERE ENTRAMBI I BOTTONI PER ENTRARE NEL PARAM.
 GIVES ACCESS TO CHANGES**

SPOSTARE I VALORI / UP-DOWN VALUE
 SALVARE / SAVED A CHANGE
SAVE A CHANGE

PER USCIRE DALLA PROGRAMMAZIONE ASPETTARE CIRCA 30 SEC.
EXIT TO THE MENU, WAIT 30 SEC.

PER PROGRAMMAZIONE CONSULTARE LISTA PARAMETRI
FOR PROGRAMATION SEE TABLE 1-MANUAL-EKC331-1.M.S

CONNETTORE RAPIDO / FAST CONNECTOR

1	2	3	4	5	6	7	8	9	10
11	12	13	14	15	16	17	18	19	20

1 UP morsetto/clamp →
1 DOWN morsetto/clamp →

cod. **UQ39E001E**

Tensione/Voltage/Spinning 380V-400V/3Ph/50-60Hz
 220V-230V/3Ph/50-60Hz

Max. 034C
 Aux. voltage 230Vcc

Defin 19/02/06
 D.I.C. DIVISIONE IMPIANTI/CENTRALI Imp 97049

Scale 1 : X
REGOLAZIONE ELETTRONICA / ELECTRONIC REGULATION / ELEKTRONISCHE STEUERUNG

Disegn. **DANFOSS EKC331/T**

Verifica **UTQ 39E1 0 E**

A.T.Bozza
 A.TERRA IN LEGGE E NECESSARIE SE NON AUTORIZZATA DALLA DISTRIZIONE.
 LA RIPRODUZIONE TOTALE O PARZIALE DELLA PRESENTE DOCUMENTAZIONE.

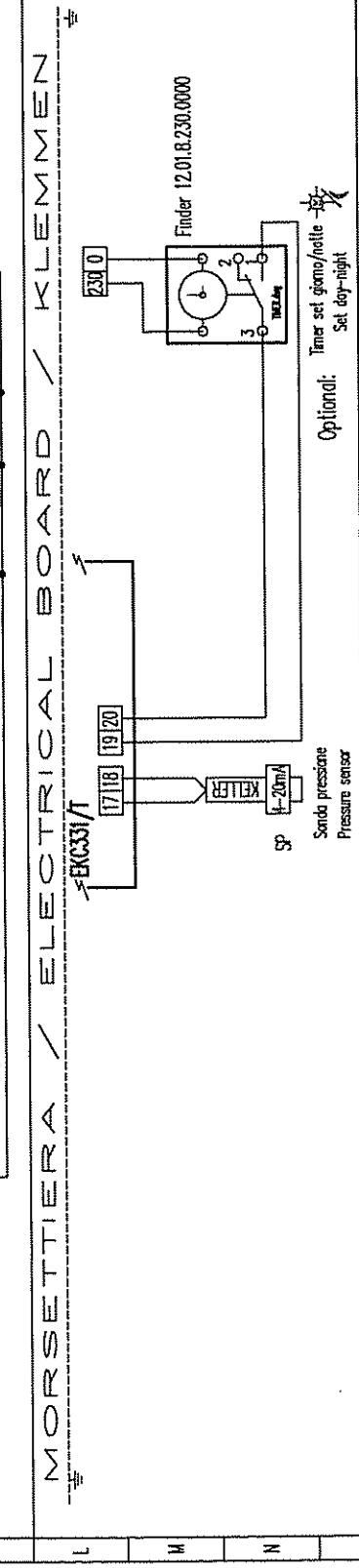

TARATURE SETTINGS		DANFOSS EKC331/T		regolatore elettronico/electronic regulation ver. 1.1marzo 2006		
centrali a 3-4 compressori 3-4 compressors packs						
FUNCTION	FUNZIONE	PARAM.	MIN	MAX	Centrali / Packs TN BT	
1	shows the signal from the pressure transmitter	-	°C		°C	
REFERENCE	LIMITI DI RIFERIMENTO					
2	set the regulation's pressure reference	-	-60°C	50°C	-13°C	-36°C
3	neutral zone	r01	0.1K	20K	4K	3K
4	Max. limitation of pressure setting	r02	-60°C	50°C	0°C	-20°C
5	Min. limitation of pressure setting	r03	-60°C	50°C	-18°C	-40°C
6	Correction of signal from the sensor	r04	-20K	20K	0°C	0°C
7	select unit (0=bar / 1 psig)	r05	C-b	F-P	C-b	C-b
8	Reference displacement by signal at Di input	r13	-50K	50K	3K	5K
CAPACITY	REGOLAZIONE					
9	min. On time for relays	c01	0 min.	30 min.	2 min.	2 min.
10	min. time period between cutins of same relay	c07	0 min.	30 min.	5 min.	5 min.
11	definition of regulation mode					
	1: sequential	c08	1	3	2	2
	2: cyclic					
	3: cyclic with unloaders					
12	If the unloaders mode 3 has been selected, the relays for the unloaders can be defined to:					
	0: cut in when more capacity is required	c09	0	1	//	//
	1: cut out when more capacity is required					
13	regulation parameter for +Zone	c10	0.1K	20K	3 K	2 K
14	regulation parameter for +Zone min.	c11	0.1min	60 min	3 min	2 min
15	regulation parameter for ++Zone seconds	c12	1 sec	180 sec	90 sec	60 sec
16	regulation parameter for -Zone	c13	0 K	20 K	3 K	2 K
17	regulation parameter for -Zone min.	c14	0.1 min	60 min	1 min	0.5 min
18	regulation parameter for -Zone seconds	c15	1 sec	180 sec	15 sec	5 sec
ALARM	ALLARMI					
19	alarm's time delay	A03	0 min.	90 min.	60 min.	60 min
20	upper alarm limit (absolute value)	A10	-50 °C	80 °C	5 °C	-15 °C
21	lower alarm limit (absolute value)	A11	-50 °C	80 °C	-22 °C	-44 °C
MISCELLANEOUS	VARIE					
22	controllers adress	o03*	1	60	-	-
23	on/off switches (service pin message)	o04*	-	-	-	-
24	access code	o05	off(-1)	100	off	off
25	define input signal / regulation stopped					
	1: 4-20mA pressure transmitter - compressor reg.					
	2: 4-20mA pressure transmitter - condenser reg.					
	3: AKS 32R pressure transmitter - compressor reg.					
	4: AKS 32R pressure transmitter - condenser reg.					
	5: 0-10V relay module					
	6: 0-5V relay module					
	7: 5-10V relay module					
	8: Pt 1000 ohm sensor - compressor reg.					
	9: Pt 1000 ohm sensor - condenser reg.					
	10: Ptc 1000 ohm sensor - compressor reg.					
	11: Ptc 1000 ohm sensor - condenser reg.					
22	set supply voltage frequency	o12	50hz	60hz	50/60	
23	manual operation with "x" relays	o18	0	4	0	
24	define number of output relays	o19	1	4	3 (3 compressors) 4 (4 compressors)	
25	Pressure trasmitter's working range - min. value	o20	-1bar	0bar	-1bar	
26	Pressure trasmitter's working range - max. value	o21	1bar	40bar	7bar	
27	Define Di input:					
	0: not used					
	1: Contact displaces reference	o22	0	2	1	1
	2: Start and stops regulation					
28	Operating hours of relay1 (value times 100)	o23	0h	100h		
29	Operating hours of relay2 (value times 100)	o24	0h	100h		
30	Operating hours of relay3 (value times 100)	o25	0h	100h		
31	Operating hours of relay4 (value times 100)	o26	0h	100h		
32	setting of refrigerant					
	1=R12, 2=R22, 3=R134A, 4=R502, 5=R717 6=R13, 7=R13B1, 8=R23, 9=R500, 10=R503 11=R114, 12=R142B, 13=user defined, 14=32R 15=R227, 16=R401A, 17=R507, 18=R402A, 19=R404A, 20=R047C, 21=R407A, 22=R407B 23=R410A, 24=R170, 25=R290, 26=R600, 27=R600A, 28=R744(CO2) 29=R1270, 30=R417A	o30	1	30	19 (R404A) 2 (R22)	
Note :	Note :					
*This setting will only be possible if a data communication module has been installed in the controller	*questo parametro è da impostare se nel controllore è stato inserito il modulo di comunicazione (es. echelon RT10)					

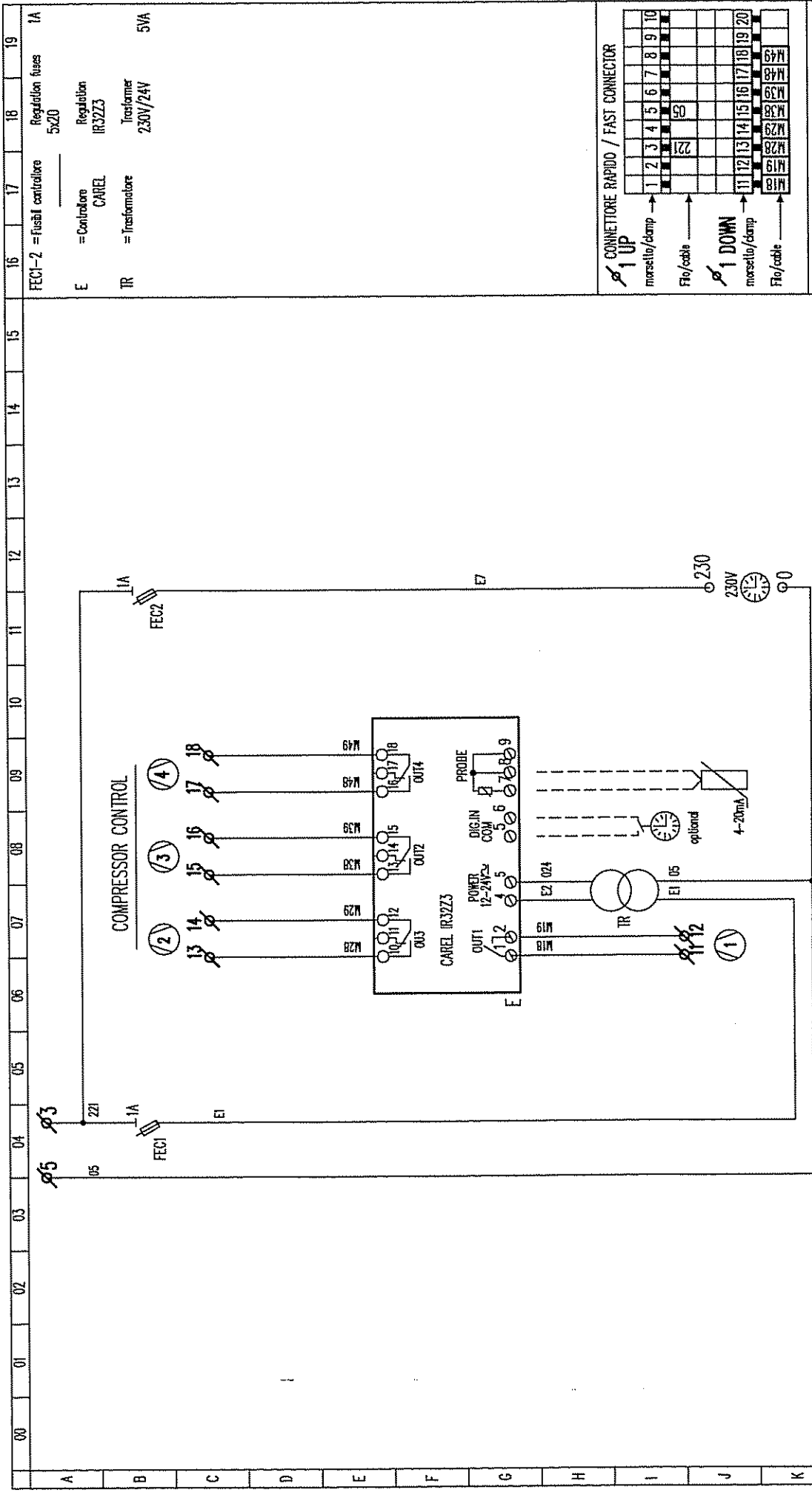

MORSETTIERA / ELECTRICAL BOARD / KLEMMEN

cod. **UQ39E002E**

Tensione/Voltage/Spannung 380V-400V/3PH/50-60Hz
 220V-230V/3PH/50-60Hz

Tem. C34C
 Max. voltage
 230Vdc

Orig 20/02/06
 Scale 1 : X
 Dis. NET
 Dis. A.Tibollo
 Verifica

D.I.C. DIVISIONE IMPIANTI/CENTRAU Inv. 97649

REGOLAZIONE ELETTRONICA CAREL
ELECTRONIC REGULATION R3ZZ3
ELEKTRONISCHE STEUERUNG

Dian.
UQ39E20
 Prog.

A FORME DI LEGGE E' TRASCRITTO SE NEI AUTOREZZATI SULLA CUSTODIA
 LA RIPRODUZIONE TOTALE O PARZIALE DELLA PRESSIONE DOCUMENTAZIONE.

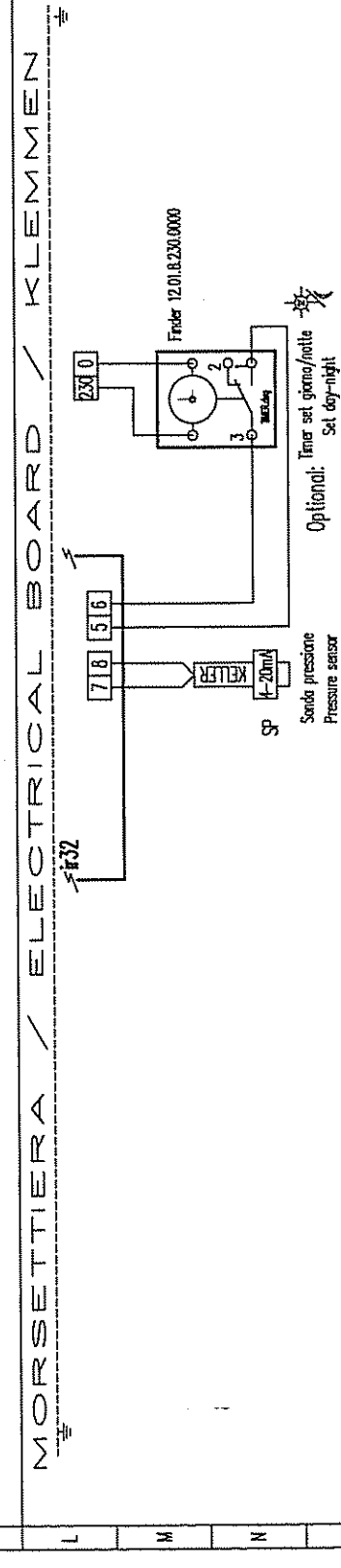

16 = Fusibili controllatore Regulation fuses 1A
 17 = Controllore CAREL
 18 = Trasformatore 230V/24V 5VA

19

CONNETTORE RAPIDO / FAST CONNECTOR

1	2	3	4	5	6	7	8	9	10
morsetto/damp									
File/cable									
221									
morsetto/damp									
File/cable									
M18	M19	M20	M21	M22	M23	M24	M25	M26	M27
M28	M29	M30	M31	M32	M33	M34	M35	M36	M37
M38	M39	M40	M41	M42	M43	M44	M45	M46	M47
M48	M49	M50	M51	M52	M53	M54	M55	M56	M57

Taratara / Settings CUBE COOLER 3-4 compressori/compressors		ver.1.1		27/05/2006	
Controllore / Capacitor CAREL IR32Z3 +Sonda di pressione / Pressure sensor KELLER 4-20mA (-1,0 / 7 Bar)		person: Adriano Tibolla			
<p>Programmazione:</p> <p>a) premere contemporaneamente i tasti PRG-mute + SEL per 5sec.</p> <p>b) sul display compare 0</p> <p>c) impostare la password 77 con il tasto (freccia su)</p> <p>d) premere il tasto SEL per confermare la password</p> <p>e) se la password è corretta compare il parametro C0</p> <p>f) procedere nella programmazione come sotto</p>		<p>Settings</p> <p>a) press "prg-mute"+"SEL" simultaneously for 5 seconds.</p> <p>b) the display shows 0;</p> <p>c) select the password "77" by ▲(arrow up)</p> <p>d) press "SEL" to confirm the password</p> <p>e) if the select password is correct, the display shows C0</p> <p>f) to modify the value of the parameter follow the procedure described above</p>			
Par.	Descrizione	CAREL	R404A	Centrali	R22
C0	Modo di funzionamento	unità m.	TN	TN	BT
P1	Differenziale set-point 1	BAR	2	7	7
P2	Differenziale set-point 2	BAR	2.0	0.6	0.4
C4	Autoria	BAR	2.0	0.6	0.4
C5	Tipo di refrigerazione	BAR	//	//	//
C6	Ritardo tra gli inserimenti relè diversi (compressori)	SEC	0	0	0
C7	Tempo minimo tra le accensioni dello stesso relè (compressore)	SEC	5	60	30
C8	Tempo minimo di spegnimento dello stesso relè (compressore)	MIN	0	5	5
C9	Tempo minimo di accensione stesso relè (compressore)	MIN	0	2	2
C10	Stato relè in caso di allarme	MIN	0	2	1
C11	Relazione uscite	MIN	0	0	0
C12	Tempo di ciclo funzionamento PWM	SEC	0	1	1
C13	Tipo di sonda	SEC	//	//	//
P14	Calibrazione sonda offset	°C	0.0	0.0	0.0
C15	Valore minimo per ingresso I e V	SEC	0.0	0.0	0.0
C16	Valore massimo per ingresso I e V	SEC	-1.0	-1.0	-1.0
C17	Velocità risposta sonda (filtro antistatico)	SEC	100	7	7
C18	Selezione unità sonda 0°=C, 1°=F	SEC	5	5	5
C19	Funz. 2° sonda: solo versione NTC	SEC	0	0	0
C21	Valore minimo set-point 1	BAR	//	//	//
C22	Valore massimo set-point 1	BAR	min. sonda	2.3	0.4
C23	Valore minimo set-point 2	BAR	max. sonda	4.0	1.5
C24	Valore massimo set-point 2	BAR	min. sonda	2.5	0.6
P25	Set allarme di bassa (assoluto)	BAR	max. sonda	4.2	1.7
P26	Set allarme di alta (assoluto)	BAR	min. sonda	1.7	0.2
P27	Differenziale di allarme	BAR	max. sonda	5.0	2.7
P28	Tempo di ritardo attuazione di allarme	°C	2.0	0.5	0.5
C29	Gestione ingresso digitale 1	MIN	60	45	30
C30	Gestione ingresso digitale 2	MIN	0	4	4
C31	Stato uscite in caso di allarme da ingresso digitale	Config of digital input 1	0	0	0
C32	Indirizzo per connessione seriale	Digital input 2	0	0	0
C33	Non modificare questo parametro	Status of the outputs in case of alarm condition detected via digital input	0	0	0
C50	Abilitazione tastiera (TS) e telecomando (TC)	Address of unit for serial connection	1	1	1
C51	Codice per abilitazione comando	Do NOT modify this parameter	0	0	0
S11	Set-point: Per impostare set-point premere tasto "SEL" per 5sec.	Activation of Keypad and remote Control	1	1	1
S12	Set-point 1	Code to activate the IR remote control	0	0	0
	Set-point 2	Set-point: press "SEL" for 5 seconds for change set-points	20	2.8(-14°C)	2.1(-14°C)
		Set-point 1	40	3.3(-10°C)	2.6(-10°C)
		Set-point 2			0.3(-35°C)
					0.7(-30°C)

Nota: Con la programmazione C0=77 lo strumento è predisposto per il funzionamento con 2 set point

a) set point 1 = day ; is activen when it open the digital input (clumps electrical board C1-D1)

b) set point 2 = notturno ; attivo quando l'ingresso digitale è chiuso - moravelli, o.c. C1-D1 (segnale esterno)

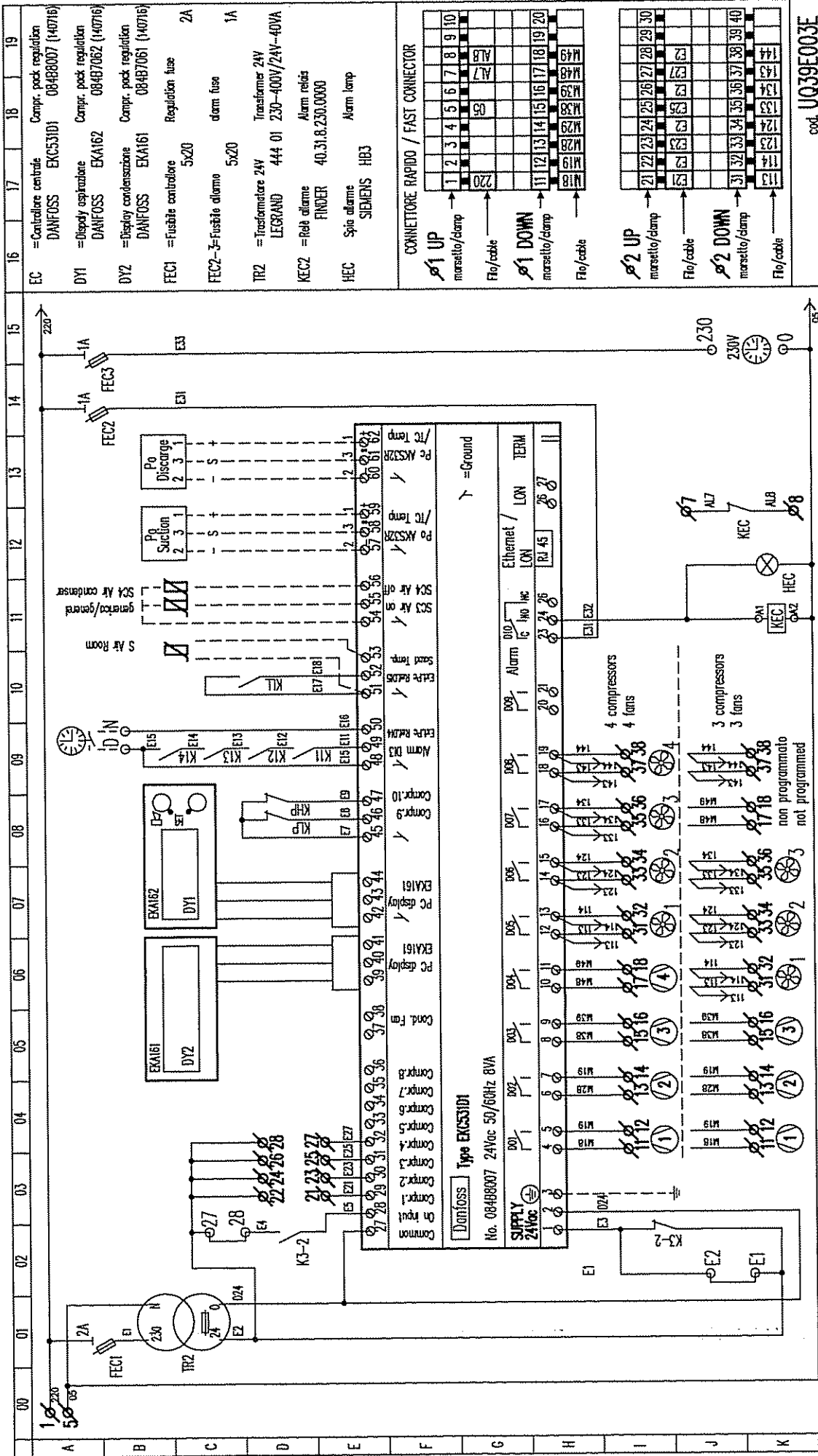

Tensione/Voltage/Spannung	380V-400V/3Ph/50-60Hz 220V-230V/3Ph/50-60Hz
Im. C34C	
Aux. voltage	230Vdc
cod.	UQ39E003E
Data	04/06/06
Scale	1: X
Desc	REGOLAZIONE ELETTRONICA ELECTRONIC REGULATION
Dis.	NET
Dis.	A. Trovati
Verifica	A. Trovati
Disart.	DANI FOSS EXCS31D1
Fog.	UTQ 39E30 EA

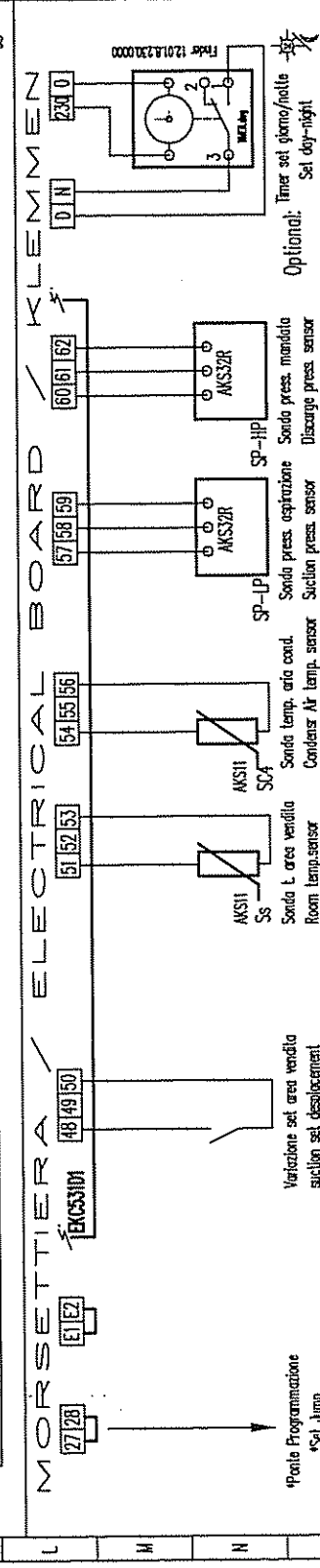

*Ponte Programmazione section set displacement
 *Set Jump
 Variazione set area vendita section set displacement
 Sonda L area vendita Room temp-sensor
 Sonda T area vendita Room temp-sensor
 Sonda temp. aria cond. Condenser Air temp. sensor
 Sonda press. aspirazione Suction press. sensor
 Sonda press. mandata Discharge press. sensor
 Timer set giorno/night Set day-night
 Optional:

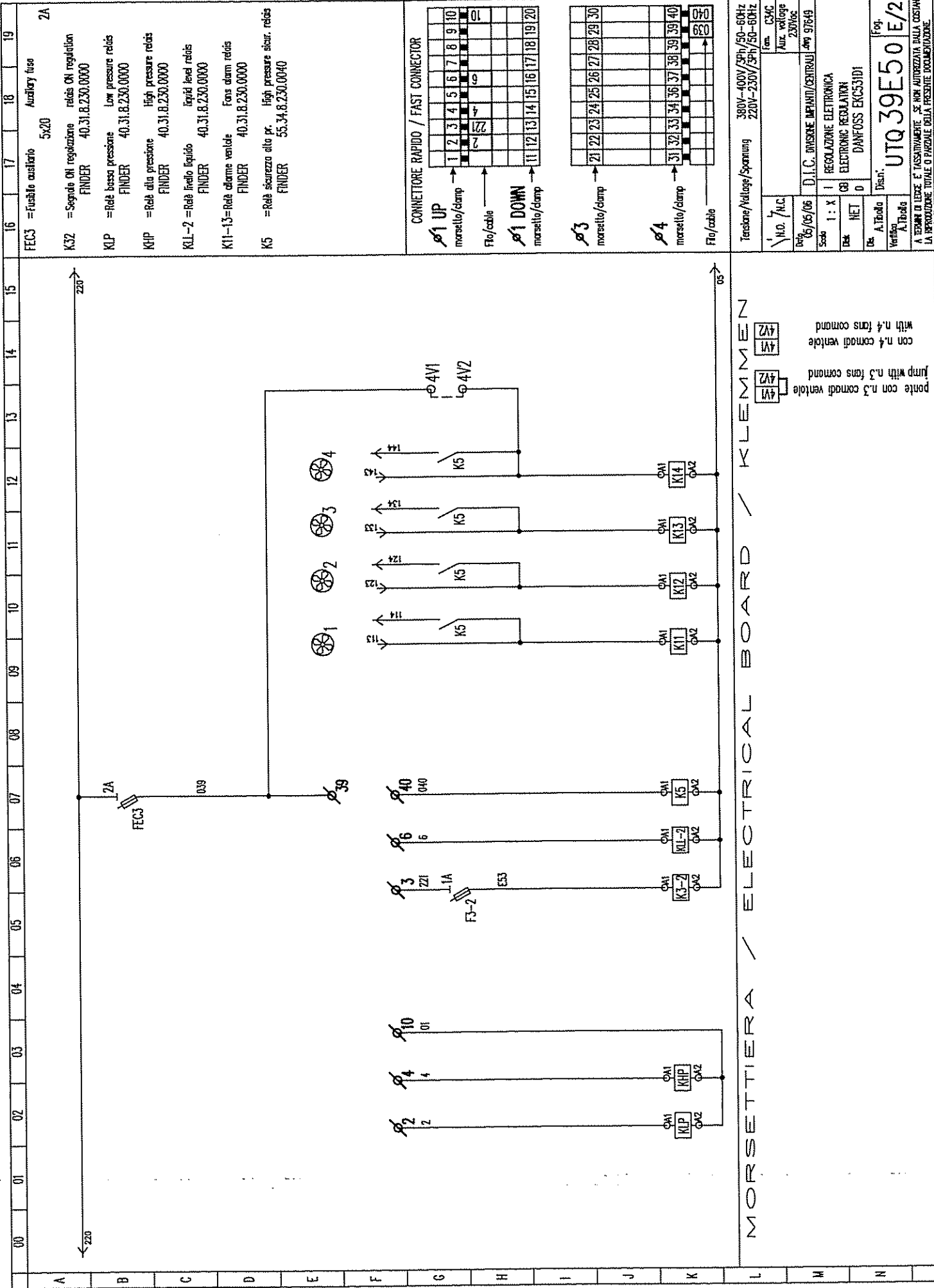

MORSETTIERA / ELECTRICAL BOARD / KLEMMENZ

4V1
 4V2
 4V3
 4V4
 4V5
 4V6
 4V7
 4V8
 4V9
 4V10
 4V11
 4V12
 4V13
 4V14
 4V15
 4V16
 4V17
 4V18
 4V19
 4V20
 4V21
 4V22
 4V23
 4V24
 4V25
 4V26
 4V27
 4V28
 4V29
 4V30
 4V31
 4V32
 4V33
 4V34
 4V35
 4V36
 4V37
 4V38
 4V39
 4V40
 4V41
 4V42
 4V43
 4V44
 4V45
 4V46
 4V47
 4V48
 4V49
 4V50
 4V51
 4V52
 4V53
 4V54
 4V55
 4V56
 4V57
 4V58
 4V59
 4V60
 4V61
 4V62
 4V63
 4V64
 4V65
 4V66
 4V67
 4V68
 4V69
 4V70
 4V71
 4V72
 4V73
 4V74
 4V75
 4V76
 4V77
 4V78
 4V79
 4V80
 4V81
 4V82
 4V83
 4V84
 4V85
 4V86
 4V87
 4V88
 4V89
 4V90
 4V91
 4V92
 4V93
 4V94
 4V95
 4V96
 4V97
 4V98
 4V99
 4V100

ponte con n.3 fans ventole
 Jump with n.3 fans ventole
 con n.4 fans ventole
 with n.4 fans ventole

16 FEC3 =Fusibile ausiliario 5x20
 17 Ausiliario fusore 2A
 18
 19

K32 = Segnale ON regolazione relais ON regulation FINDER 40.31.8.2.30.00000
 KLP =Retè basso pressione Low pressure relais FINDER 40.31.8.2.30.00000
 KHP =Retè alta pressione High pressure relais FINDER 40.31.8.2.30.00000
 KLL-2 =Retè livello liquido Liquid level relais FINDER 40.31.8.2.30.00000
 K11-1,3=Retè allarme ventole Fans alarm relais FINDER 40.31.8.2.30.00000
 K5 =Retè sicurezza alta pr. High pressure secur. relais FINDER 55.34.8.2.30.00040

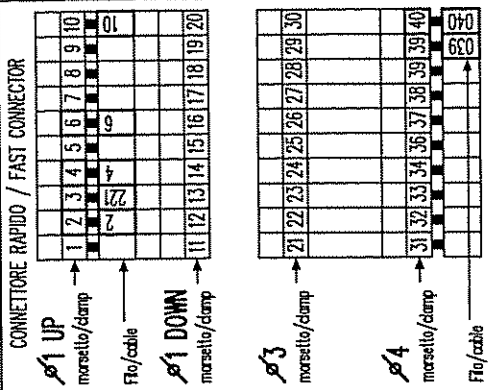

Tensione/Voltage/Spinning 380V-600V/50/60-60Hz
 220V-230V/50/60-60Hz
 tem. C3AC
 Aux. voltage 230Vdc

Dato 06/05/06
 Scale 1: X
 Dis. A. Trabold
 Verificato A. Trabold
 D.I.C. DIVISIONE IMPIANTI/CENTRAU Imp 97649
 I REGOLAZIONE ELETTRONICA
 CB ELECTRONIC REGULATION
 DANFOSS EK531D1

Fog. 1
UTQ39E50 E/2

A TERAPIA DI LEGGE È ASSERVAMENTE SE NON AUTORIZZATA DALLA COSTRUTTORE LA RIPRODUZIONE TOTALE O PARZIALE DELLA PRESENTE DOCUMENTAZIONE.

		regolatore elettronico/electronic regulation ver. 1.0 giugno / june 2005				
TARATURE SETTINGS		DANFOSS EKC531D1 084B8007 - sw 1.22 centrali / compressors pack CNS 3/6G-3/6V				
					TN-r404a	BT-r404a
FUNCTION	FUNZIONE	PAR.	MIN	MAX		
1	shows Po in EKA 162 (display with buttons)		°C			
2	shows Pc in EKA 161		°C			
PO REFERENCE		PO REGOLAZIONE ASPIRAZIONE				
3	neutral zone	r01	0.1°C	20°C	3	2
4	correction signal from PO sensor	r04	-10°C	10°C	0	0
5	select unit (0=bar / 1 psig)	r05	0	1	0	0
6	start/stop regulation	r12	OFF	ON	ON	ON
7	reference offset for PO	r13	-20°C	20°C	4	2
8	Set regulation setpoint for PO	r23	-99°C	30°C	-10	-35
9	Shows total PO reference	r24	°C			
10	Limitation : PO reference max. value*	r25	-99°C	30°C	0	-20
11	Limitation : PO reference min. value*	r26	-99°C	0°C	-15	-39
12	manual displacement of PO(ON=active *r13*)	r27	OFF	ON	OFF	OFF
PC REFERENCE		PC REGOLAZIONE MANDATA				
13	Set regulation setpoint for PC	r28	-25°C	75°C	32	32
14	Shows total PC reference	r29	°C			
15	Limitation : PC reference max. value	r30	-99°C	99°C	45.0	45.0
16	Limitation : PC reference min. value	r31	-99°C	99°C	20.0	20.0
17	correction signal from PC sensor	r32	-10°C	10°C	0.0	0.0
18	PC reference variation					
19	1 and 2 are PI-regulation					
20	1: Fixed reference *r28* is used					
21	2: variable reference :out door temperature (Sc3)	r33				
22	included in the reference		1	4	1	1
23	3: As 1, but with P - regulation					
24	4: As 2, but with P - regulation					
25	Reference offset for PC	r34	-20°C	20°C	0.0	0.0
COMPRESSOR CAPACITY		REGOLAZIONE COMPRESSORI				
26	min. On time for relays	c01	0 min.	30 min.	2	2
27	min. time period between cutins of same relay	c07	0 min.	60 min.	6	6
28	definition of regulation mode					
29	1:sequential (step mode / FILO)					
30	2:cyclic (step mode / FIFO)	c08	1	3	2	2
31	3: cyclic with unloaders					
32	If the unloaders mode 3 has been selected,the					
33	relays for the unloaders can be defined to:					
34	0: cut in when more capacity is required	c09	0	1	//	//
35	1: cut out when more capacity is required					
36	Regulation parameter for + Zone	c10	0,1 K	20 K	3	2
37	Regulation parameter for + Zone min.	c11	0,1 min	60 min.	3	2
38	Regulation parameter for ++ Zone min.	c12	0,1 min	3,0 min.	1	0,5
39	Regulation parameter for - Zone	c13	0,1 K	20 K	3	2
40	Regulation parameter for - Zone min.	c14	0,1 min	60 min.	0,5	0,3
41	Regulation parameter for -- Zone seconds	c15	0,02 min	20 min.	0,2	0,1
42	Definition of compressor connections.	c16	0	26	3 compr.= 3	
	<i>See the options on page 10 EKC531D1 Manual</i>				4 compr.= 4	
					5 compr.= 9	
					6 compr.=10	
43	The following *c17* to *c28* is only relevant if *c16* has been select to 0. A cada will then have to be set for the relays that are to be ON at the different steps.				//	//
44	Step 1 (M&M operation)	c17	0	15		
45	Step 2 (M&M operation)					
46	Step 3 (M&M operation)	c18	0	15		
47	Step 4 (M&M operation)	c19	0	15		
48	Step 5 (M&M operation)	c20	0	15		
49	Step 6 (M&M operation)	c21	0	15		
50	Step 7 (M&M operation)	c22	0	15		
51	Step 8 (M&M operation)	c23	0	15		
52	Step 9 (M&M operation)	c24	0	15		
53	Step 10 (M&M operation)	c25	0	15		
54	Step 11 (M&M operation)	c26	0	15		
55	Step 12 (M&M operation)	c27	0	15		
56	Definition of fan connection and number:	c28	0	15		
57	1-8 :Total Number of fans	c29	0/off	9	3 fans.= 3	
58	9 :Only via analog output and frequency converter				4 fans.= 4	
59	Amplification factor Xp for (P=100/Xp)				5 fans.= 5	
60	condenser regulation	n04	0,2 K	40K	10	10
61	i: integration time Tn for condenser regulation	n05	30 s	600 s	150	150
ALARM		ALLARMI				
62	Delay time for a "Housing" alarm	A03	0 min	90 min	90	90
63	Low alarm limit for PO	A11	-99°C	30°C	-25	-42
64	Delay time for a DI1 alarm	A27	0 sec	600s/off	599	
65	Delay time for a DI2 alarm	A28	0 sec	600s/off	599	

66	Delay time for a DI3 alarm	ritardo per allarme DI3	A29	0 sec	600s/off	599	
67	Upper alarm limit for Pc	limite allarme superiore per PC	A30	0 °C	99 °C	53,0	53,0
68	Upper alarm limit for sensor "Housing"		A32	0° C/off	100°C	100	100
MISCELLANEOUS			VARIE				
69	controllers adress	indirizzo controllore	o03*	1	60	-	-
70	on/off switches (service pin message)	on/off microinteruttori (messaggi pin)	o04*	-	-	-	-
71	access code	codice di accesso	o05	off(-1)	100	off	off
72	Used sensor type for Sc3; Sc4 and "Housing"		o06	0	1	1	1
73	0=PT1000, 1=PTC1000						
74	set supply voltage frequency	settaggio frequenza di alimentazione	o12	50hz	60hz	50/60	50/50
75	manual operation with "x" relays	azionamento manuale del relè					
76	0: no override	0: no azionato					
77	1-10: 1=will cut in relay; 2 relay 2 etc..	1-10 prova relè : 1=inserimento relè 1; 2 ecc...	o18	1	18	0	0
78	11-18: Gives voltage signal on the analog output	11-18 da tensione in volt sulle uscite analogiche					
79	(11 gives 1.25V, and so on in the steps of 1.25V)	(11 da 1.25V e così per le uscite a 1.25V)					
80	Po Pressure trasmitter's working range - min. value	range min. della sonda di press.di aspirazione	o20	-1bar	0bar	-1	-1
81	Po Pressure trasmitter's working range - max. value	range max. della sonda di press.di mandata	o21	1bar	40bar	9 (12)**	9 (12)**
82	Define DI4 input:	Definizione DI input					
83	0: not used	0: non usato	o22	0	2	1	1
84	1: PO displacement	1: spostamento set tramite contatto					
85	2: alarm function. Alarm="A31"	2: Start and stop della regolazione					
86	Operating hours of relay1 (value times 100)	contaore relè n.1	o23	0h	100h		h
87	Operating hours of relay2 (value times 100)	contaore relè n.2	o24	0h	100h		h
88	Operating hours of relay3 (value times 100)	contaore relè n.3	o25	0h	100h		h
89	Operating hours of relay4 (value times 100)	contaore relè n.4	o26	0h	100h		h
90	setting of refrigerant 1=R12, 2=R22, 3=R134A, 4=R502, 5=R717 6=R13, 7=R13B1, 8=R23, 9=R500, 10=R503 11=R114, 12=R142B, 13=user defined, 14=32R 15=R227, 16=R401A, 17=R507, 18=R402A 19=R404A, 20=R047C, 21=R407A, 22=R407B 23=R410A, 24=R170, 25=R290, 26=R600, 27=R600A, 28=R744(CO2) 29=R1270, 30=R417A	settaggio refrigeranti	o030	0	30	19	19
91	Define DI5 input:	Definizione input DI5					
	0: not used	0: non usato	o37	0	2		2=liquid level / livello liquido
	1: Pc displacement	1: spostamento set tramite contatto					
	2: alarm function. Alarm="A32" (liquid level)	2: allarme generico ALARM="A32" (livello liquido)					
92	Pc Pressure trasmitter's working range - min. value	range min. della sonda di press.di mandata	o47	-1bar	0bar	-1	-1
93	Pc Pressure trasmitter's working range - max. value	range max. della sonda di press.di mandata	o48	1bar	40bar	34	34
94	Read temperature at sensor Housing	lettura temperatura alla sonda Housing	o49				
95	Operating hours of relay5 (value times 100)	contaore relè n.5	o50	0h	100h		h
96	Operating hours of relay6 (value times 100)	contaore relè n.6	o51	0h	100h		h
97	Operating hours of relay7 (value times 100)	contaore relè n.7	o52	0h	100h		h
98	Operating hours of relay8 (value times 100)	contaore relè n.8	o53	0h	100h		h
99	Operating hours of relay9 (value times 100)	contaore relè n.8	o54	0h	100h		h
100	Operating hours of relay10 (value times 100)	contaore relè n.9	o55	0h	100h		h
SERVICE			FUNZIONE				
101	Read temperature at sensor "Sc3"	visualizza la temperatura del sensore "Sc3"	u44	°C			
102	Read temperature at sensor "Sc4"	visualizza la temperatura del sensore "Sc4"	u45	°C			

The controller can give the following messages	Il controllore segnala i seguenti mess. di errore	
Error message : fault in controller	errore controllore	E1
Error message : regulation is outside the range, or the control signal is defective	il controllore è al di fuori del range o il controllo del segnale è difettoso	E2
Alarm message	Messaggi di allarme	
Low PO	Bassa pressione	A2
Refrigerant not selected	refrigerante non selezionato	A11
High PC	Alta pressione	A17
Compressor 1 alarm: Terminal 29 is open.	Allarme compressore 1: il morsetto 29 è aperto	A19
Compressor 2 alarm: Terminal 30 is open.	Allarme compressore 2: il morsetto 30 è aperto	A20
Compressor 3 alarm: Terminal 31 is open.	Allarme compressore 3: il morsetto 31 è aperto	A21
Compressor 4 alarm: Terminal 32 is open.	Allarme compressore 4: il morsetto 32 è aperto	A22
Compressor 5 alarm: Terminal 33 is open.	Allarme compressore 5: il morsetto 33 è aperto	A23
Compressor 6 alarm: Terminal 34 is open.	Allarme compressore 6: il morsetto 34 è aperto	A24
Compressor 7 alarm: Terminal 35 is open.	Allarme compressore 7: il morsetto 35 è aperto	A25
Compressor 8 alarm: Terminal 36 is open.	Allarme compressore 8: il morsetto 36 è aperto	A26
Room temperature alarm (housing temp.)	Allarme temperatura ambiente	A27
DI1 alarm. Terminal 46 interrupted	Allarme DI1. Morsetto 46 aperto	A28
DI2 alarm. Terminal 47 interrupted	Allarme DI2. Morsetto 47 aperto	A29
DI3 alarm. Terminal 49 interrupted	Allarme DI3. Morsetto 49 aperto	A30
DI4 alarm. Terminal 50 interrupted	Allarme DI4. Morsetto 50 aperto	A31
DI5 alarm. Terminal 52 interrupted	Allarme DI5. Morsetto 52 aperto	A32
Regulation stopped	Stop regolazione	A45
Status Message	Messaggio di stato	
Wait for "c01"	Aspetta per "c01"	S2
Wait for "c07"	Aspetta per "c07"	S5
Wait for "c11" or "c12"	Aspetta per "c11" o "c12"	S8
Wait for "c14" or "c15"	Aspetta per "c14" o "c15"	S9
Refrigeration stopped by the terminal or external start/stop function	Refrigeraz. fermata tramite ingr. digitale estemo start-stop	S10
Manual control of output	controllo manuale delle uscite	S25

NOTE:

** suction transducer -1...9 bar = 9
** suction transducer -1...12 bar = 12

** sonda aspirazione -1...9 bar = 9
** sonda aspirazione -1...12 bar = 12

E	Controllatore elettronico CAREL PC02_BUILT IN MEDIUM PC02CF051K cod.67277122	16	17	18	19
FEC	Fusibile 5x20 4A				
KCI-3	Relè aux. comp. FINDER 40.31.8.024.0000 24V				
KVC1-3	Relè aux. ventile FINDER 40.31.8.024.0000 24V				
KEC	Relè aux. ventile FINDER 40.51.024.0000 (2 contatti) 24V				
TR2	Trasformatore LEGRAND 44403 100VA				

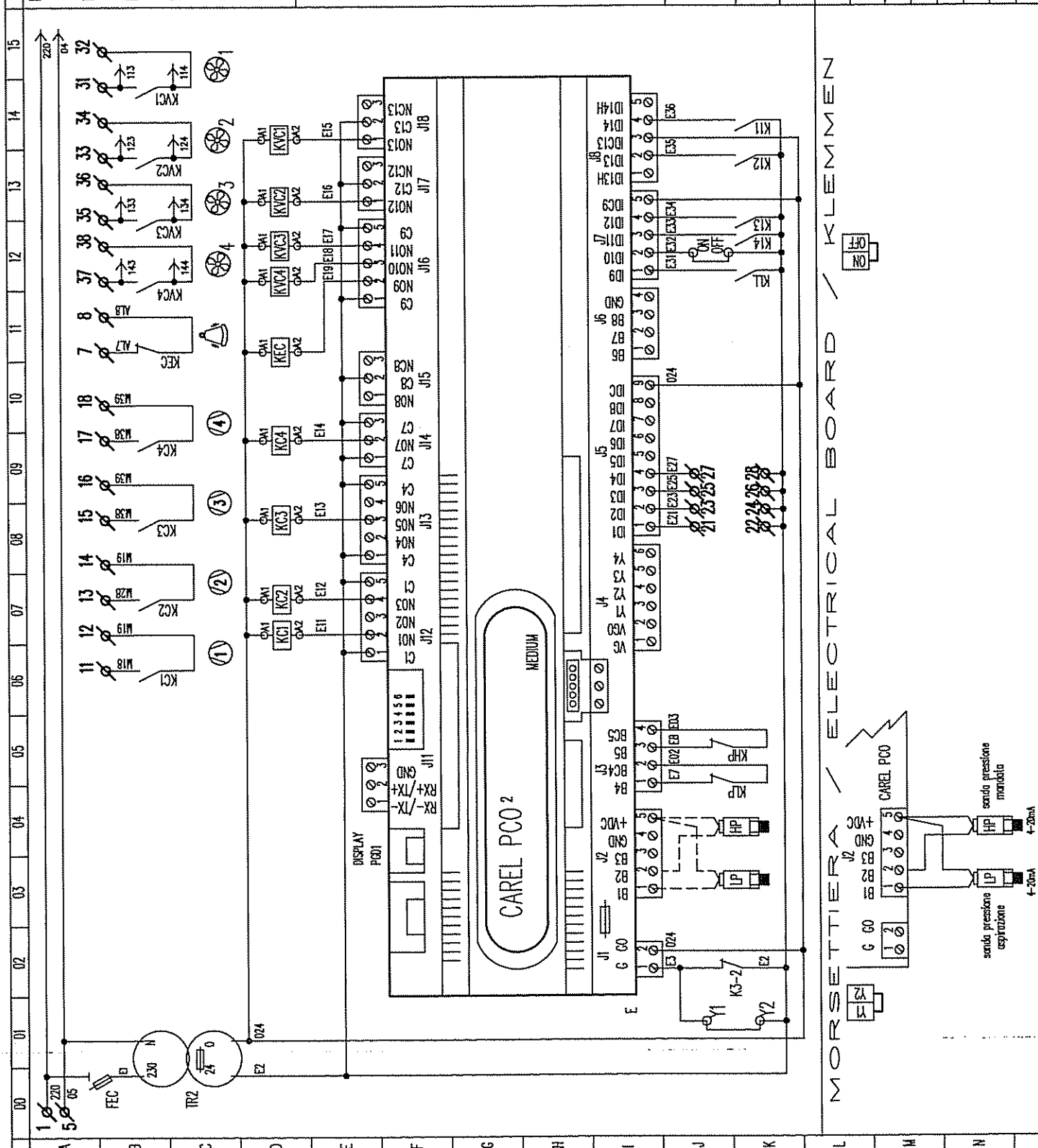

A	B	C	D	E	F	G	H	I	J	K	L	M	N
---	---	---	---	---	---	---	---	---	---	---	---	---	---

Tensione/Voltage/Spinning		380V-400V/3Ph/50-60Hz	
		220V-230V/3Ph/50-60Hz	
N.O. / N.C.		Fem. CMC	
Data		Aux. voltage 230Vac	
Dati		D.I.C. SENSORE IMPANTI/CENTRALI - n. 97619	
Scale		I REGOLAZIONE ELETTRONICA CAREL	
Tkn		CBI ELECTRONIC REGULATORS PC02-MEDIUM	
Ua		D ELETTRONISCHE STEUERUNG	
Verifica		Uien. UTQ 39E40 E/I	
		Fog. A.1040 A.1040	
A.1040 E.1040 F.1040 G.1040 H.1040 I.1040 J.1040 K.1040 L.1040 M.1040 N.1040 O.1040 P.1040 Q.1040 R.1040 S.1040 T.1040 U.1040 V.1040 W.1040 X.1040 Y.1040 Z.1040			

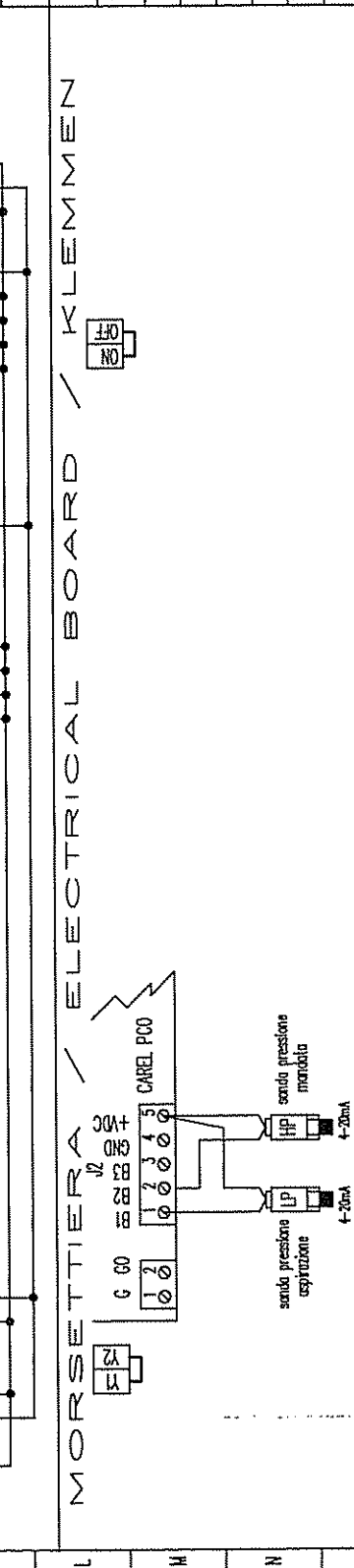

UTQ 39E40 E/I	
Fog. A.1040 A.1040	
A.1040 E.1040 F.1040 G.1040 H.1040 I.1040 J.1040 K.1040 L.1040 M.1040 N.1040 O.1040 P.1040 Q.1040 R.1040 S.1040 T.1040 U.1040 V.1040 W.1040 X.1040 Y.1040 Z.1040	

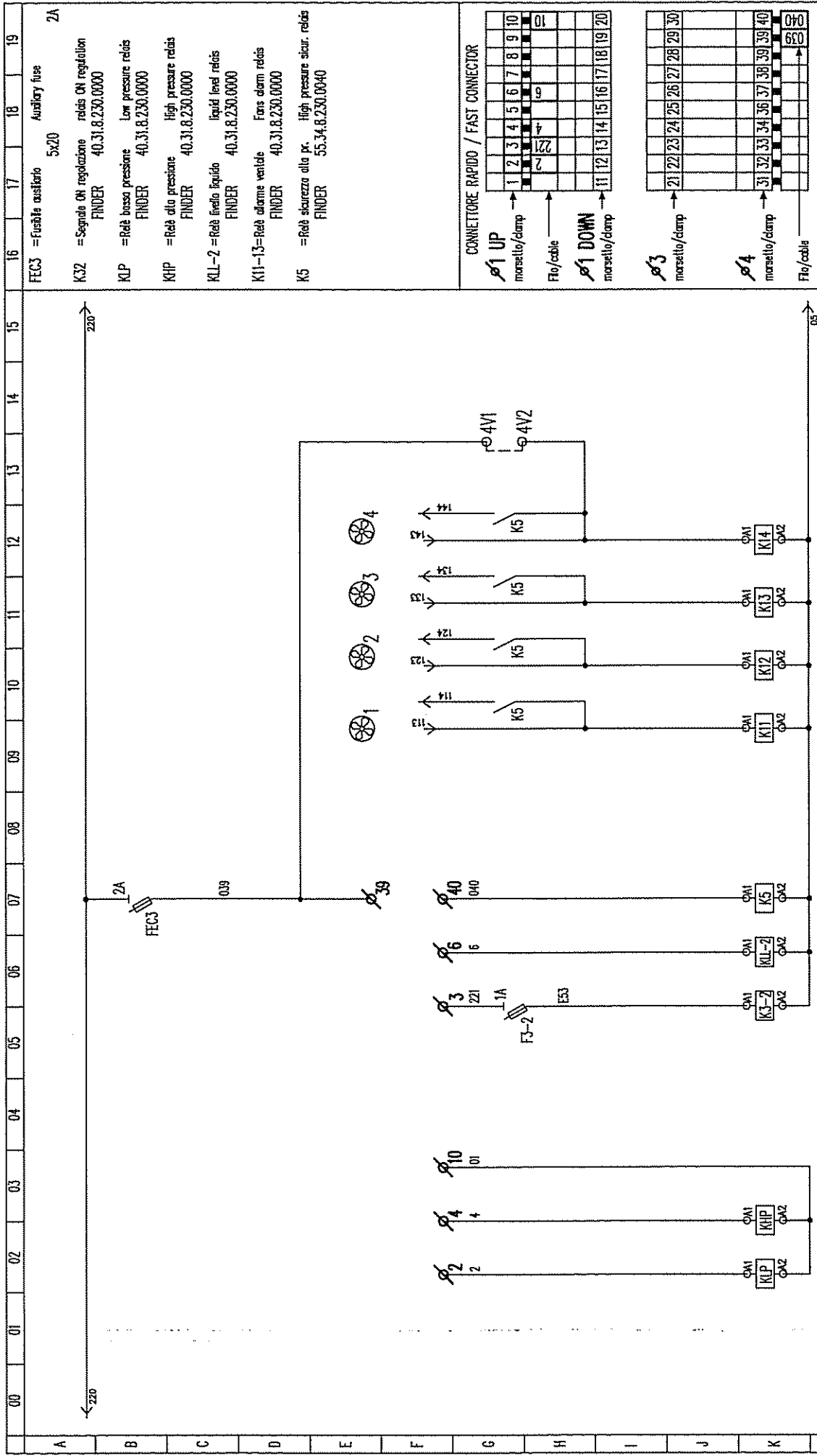

MORSETTIERA / ELECTRICAL BOARD / KLEMMENZ

Tensione/Voltage/Spinning		380V-400V/3Ph/50-60Hz	
		220V-230V/3Ph/50-60Hz	
N.O. / n.c.		Im. CMC	
Data		Aut. voltage	
16/05/06		230Vcc	
Scale	1 : X	REGOLAZIONE ELETTRONICA	
Tab.	NET	ELECTRONIC REGULATION	
Dis.	A. Tirolo	DANFOSS EXCS3101	
Verifica	A. Tirolo	Dis. n.	
		Fog.	
		UTQ39E50 E/2	

ponte con n.3 comodi ventole
 with n.3 fans comend
 con n.4 comodi ventole
 with n.4 fans comend

A. TIRILO E. C. ASSICURAMENTE SE NON AUTORIZZATA DALLA GEMAK
 LA RIPRODUZIONE TOTALE O PARZIALE PRESENTE E' DOCUMENTAZIONE.

- FEC3 = Fusibile ausiliario Auxiliary fuse 5x20 2A
- K32 = Segnale ON regolazione relais ON regulation FINDER 40.31.8.230.0000
- KLP = Retè basso pressione Low pressure relais FINDER 40.31.8.230.0000
- KHP = Retè alto pressione High pressure relais FINDER 40.31.8.230.0000
- KL-2 = Retè livello liquido liquid level relais FINDER 40.31.8.230.0000
- K11-13 = Retè allarme ventole Fans alarm relais FINDER 40.31.8.230.0000
- K5 = Retè sicurezza alta pr. High pressure secur. relais FINDER 55.34.8.230.0040

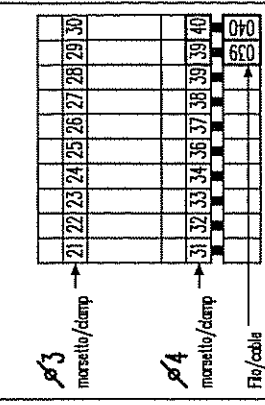
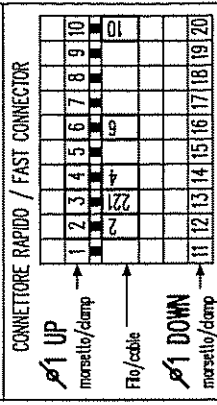

Parameter	Type	Pos.	DESCRIPTION	U. of M.	Range	Default value	TN	BT
	xls n° Ta- pco2- 02_200 5- ver_5. xls			ref. A.Tibolla person:			25/02/2005	

SETTING PROCEDURE
FOR CONTROLLER
CAREL PCO2
SOFTWARE
FLSTDMFC0A ver.1.5
document n°

QTP000161A-2

Main screens								System	
Parameter	Type	Pos.	DESCRIPTION	U. of M.	Range	Default value	TN	BT	
M0,1,...,6 Main menu branch - Menu key									
PressSuct.	R	M0	Pressure measured by the intake sensor on the compressors (suction), pressing ENTER displays the value in degrees Celsius or Fahrenheit.	bar	Screen Cd			Value reading	
Disch.Press.	R	M0	Pressure measured by the outlet sensor on the compressors (discharge), pressing ENTER displays the value in degrees Celsius or Fahrenheit.	bar	Screen Cd				
Suct. Temp.	R	M0	Temperature measured by the intake sensor on the compressors (suction), pressing ENTER displays the value in degrees Celsius, Fahrenheit or bar	C / F	(-40,+90)°C				
Disch. Temp.	R	M0	Temperature measured by the outlet sensor on the compressors (discharge), pressing ENTER displays the value in degrees Celsius, Fahrenheit or bar	C / F	(-40,+90)°C				
Compressor status	R	M1	View compressor status						
Fan Status	R	M2	View fan status						
Fan inverter status	R	M3	Fan inverter status	%	0,100				
Compressor inverter status	R	M3	Compressor inverter status	%	0,100				
Auxiliary room temperature probe	R	M4	Auxiliary room temperature probe	°C	(-40,+90)°C				
Auxiliary outside temperature probe	R	M4	Auxiliary outside temperature probe	°C	(-40,+90)°C				
Auxiliary probe (configurable)	R	M4	Auxiliary probe (can be configured as a temperature probe in C° or for detecting gas)	°C /					
Unit Status	R	M5	With built-in terminal, this screen appears and describes unit status (1: OFF from alarm; 2: OFF from supervisor, 3: Restart after Blackout, 4: OFF from remote input, 5: OFF from button, 6:>>Manual oper.<<; 7: Install. default", "OFF from screen.)	ppM	1,2,...,9				
unit?	R/W	M5	Used to switch the unit on when using a built-in terminal		No/Yes				

Clock screens								System	
Parameter	Type	Pos.	DESCRIPTION	U. of M.	Range	Default value	TN	BT	
K0,k1,...,k4 clock branch: press the clock key									
Change time	R/W	K0	Set hour, minutes		(0,23)			set date/clock	
Change date	R/W	K0	Set day, month, year		(0,59) (1,31)				

Daily time zones with setpoint variation enabled: Time band 1,2,...,4 00h 00m Set 1,2,...,4	R/W	K1	Enable time band with set point variation	(1,12)	(0,99)	N / S
	R/W	K2	Set time band 1,2...4 hours:minutes	(0,23)	7	
	R/W	K2	Set Point di lavoro durante fascia oraria (1,2...4)	(0,59)		
	R	K4	Display	min,max set comp.		
Clock not installed	R	K4	Display			

Status screens							System
Parameter	Type	Pos.	DESCRIPTION	U. of M.	Range	Default value	TN
10,11,...,1m input/output branch; press i/o key							
Digital inputs (O) open-(C)closed 01: 06: 11: 16:	R	10	Status of digital inputs 1..16				Display state Visualizzazione stato ingressi / uscite / sonde
			(C) = closed (A) = open				
Probes input: Suct Temp Disch Temp	R	11	Status of the suction and discharge probes	bar/°C / F	Screen Cc and Cd		
Auxiliary probes – Room Temp :	R	12	Status of auxiliary probe	°C	(-40,+90)°C		
Auxiliary probes – Outside Temp :	R	12	Status of auxiliary probe	°C	(-40,+90)°C		
Configurable auxiliary probes:	R	12	Status of auxiliary probe	°C /	(-40,+90)°C o masc. Cg		
Input of probe B3 Instant power input	R	13	Reading of Probe S3: If enabled, instant power input	ppM kw	Screen		
Inputs b4 - b5 (O) open-(C) b4 :C b5 :C	R	14	Status of analog inputs used as digital		Cf C / O		
			(C) = closed (O) = open				
Inputs b9 - b10 (A) open - (C) closed b9 :C b10 :C	R	15	Status of analog inputs used as digital (LARGE card); (C) = closed, (O) = open		C / O		
Digital outputs (A) open-(C) closed 01: 06:11:16:	R	16	Status of digital outputs 1..16		O / C		
			(O) = open (C) = closed				
Inverter Y1	R	17	Fan inverter status		0 , 1000		
Inverter Y2	R	17	Compressor inverter status		0 , 1000		
Input/output board configuration:	R	18	Displays type of board used		Small, Medium		
					Large		
Relay Output config. k1,k2..k18:	R	19,1a, 1e	Relay output configuration k1, k2, ..k18				
Input configuration b4,b5..b6 : 0	R	1f	Configuration of inputs b4,b5..b6				
Input configuration ID1,ID2,..ID18	R	1g,1h,..1i	Configuration of inputs ID1, ID2,.. ID18				
Input configuration b9,b10	R	1m	Configuration of inputs b9,b10				

Set-point screens

							System	
Parameter	Type	Pos.	DESCRIPTION	U. of M.	Range	Default value	TN	BT
S0,S1,...,Sc Set Point branch: premere tasto Set point								
Set. PROPORTIONAL BAND	R	S0	Shows whether compressors work in dead band or proportional band and reads the working set-point					
Diff.	R	S0	Reads compressor differential					
Fans PROPORTIONAL BAND set	R/W	S1	Enter fans set-point	bar / °C	min,max fan set	15.5	14 (+32)	
Diff.	R	S1	Reads fan differential					
Compressors PROPORTIONAL BAND set	R/W	S2	Enter compressors set-point	bar / °C	min,max comp. set	1.0	3,0 (-12)	0,6 (-36)
Compressor inverter PROPORTIONAL BAND set	R/W	S3	Enter compressor inverter set-point	bar / °C	min,max comp. set	1.0	-	-
Fan Inverter PROPORTIONAL BAND set	R/W	S4	Enter fan inverter set-point	bar / °C	min,max fan set	15.5	-	-
Enter setpoint password:	R/W	S5	Enter setpoint password		0, 9999	0	-	-
Compressor inverter Offset :	R/W	S6	Compressor inverter offset setting	bar / °C	min,max comp. set		-	-
Climb up inverter time :	R/W	S6	Time taken by the inverter to reach full output	V	0, 10.0	2	-	-
Fan inverter Offset :	R/W	S7	Fan inverter offset setting	bar / °C	min,max fan set		-	-
Climb up inverter time:	R/W	S7	Time taken by the inverter to reach full output	V	0, 10.0	1.0	-	-
Set compressor diff:	R/W	S8	Settings compressor differential	bar / °C	0, 20.0	0.5	0,5 (4°C)	0,5 (4°C)
Set fan diff:	R/W	S8	Settings compressor differential	bar / °C	0, 20.0	2.0	2,0 (5°C)	
Inverter differential compr. Inver.	R/W	S9	Settings compressor inverter differential	bar / °C	0, 99.9	0.5	-	-
Fan Inverter	R/W	S9	Settings fan inverter differential	bar / °C	0, 99.9	2.0	-	-
Enter new password:	R/W	Sa	Enter a new set-point password		0, 9999	0	-	-

Maintenance screens

							System	
Parameter	Type	Pos.	DESCRIPTION	U. ofM.	Range	Default value	TN	BT
A0,A1,...,Ai – B0,B1,...,Bs maintenance branch : press maintenance key								
Compressor working hours	R	A0,A1	Displays the operating hours of compressors 1,2,...,6	hours	0,999999			maintenance screens/ settings
Fan working hours	R	A2,A3, 1,2,..6 :	Displays the operating hours of fans 1,2,...,16	hours	0,999999			
Instant Delta efficiency	R	A7	Displays the instant efficiency value	%	0,99.9			
Delta efficiency Current daily	R	A8	Displays the current daily, monthly and annual efficiency	%	0,99.9			
Current monthly								
Current yearly								
Delta efficiency Daily old	R	A9	Displays the daily, monthly and annual old efficiency	%	0,99.9			
Monthly old								
Yearly old								
Delta efficiency	R	Aa	Indicates the time band in which the current daily efficiency percentage is calculated and displays the current daily efficiency percentage	%	0,99.9			
00:00 C-gg 00:00 C-gg att. Delta efficiency	R	Ab	Indicates the time band in which the previous daily efficiency percentage is calculated and displays the previous daily efficiency percentage and previous night-time efficiency percentage	%	0,99.9			

00:00 C-day 00:00 C-day old C-night old						
Power input instant value:	R	Ac	Displays the instant power input value	kw	0,9999	
Power input Current Day	R	Ad	Reads power input current daily (kw), current monthly (kw) and current yearly (Mw)	kw, Mw	0,999999	
Current month Current year						
Power input: Day old	R	Ae	Reads previous daily (kw) monthly(kw) yearly (kw) power input	kw, Mw	0,999999	
Month old Year old						
Total power input	R	Af	Reads total power input (Mw)	Mw	0,999999,999	
Power input:	R	Ag	Indicates the time band in which the current daily power input is calculated	kw	0,9999	
00:00 C-day 00 C-day curr.			displays the current daily power consumption as a percentage			
Power input: 00:00 C-day 00:00	R	Ah	Indicates the time band in which the daily and night- time power consumption is calculated and displays the daily power consumption as a percentage and the night- time power consumption as a percentage	kw	0,9999	
C-day : C-night:						
GSM MODEM	R	Ai	GSM Modem : GSM status and signal reception, expressed as a percentage			
Status: Range:						
Enter maintenance password:	R/W	B0	Enter maintenance password		0,9999	0
Keyboard On/Off enable:	R/W	B1	Enable ON/OFF from the keypad		Yes/No	Si
Switch-Off unit:	R/W	B1	Enable unit ON/OFF from the screen		Yes/No	Si
Delete Hystorical Alarms:	R/W	B2	Deletes the alarm log		Y/N	N
SMS test sending:	R/W	B2	Used to send a test SMS if the GSM modem is enabled		Y/N	N
Number of attempts :	R/W	B3	Set number of attempts from GSM modem. Visualizzata se abilitato modem GSM		0,9	3
Phone number: :	R/W	B3	GSM modem telephone number settings. Displayed if the GSM modem is enabled		20 digits, settable by the user	0
SMS password:	R/W	B3	GSM modem password settings. Displayed if the GSM modem is enabled			0
Description of events:	R/W	B4	This screen is sent as SMS. Visualizzata se abilitato modem GSM		Settable text:	
Alarm compressor hour meter threshold:	R/W	B5	Max compressor operating hour threshold setting. Once the threshold is exceeded, an alarm is activated.	Hours	1,999000	1000000
Alarm fan hour meter threshold:	R/W	B6	Max fan operating hour threshold setting. Once the threshold is exceeded, an alarm is activated.	Hours	1,999000	1000000
Compressors time counters reset: 1,2,...,6	R/W	B7,	The time counter of compressors can be reset		Y/N	N
Fans time counters reset: 1,2,...,16	R/W	B8,B9	The time counter of fans can be reset		Y/N	N
Power input: Day reset:	R/W	Ba	Reset daily power consumption count, reset monthly power consumption count, reset annual power consumption count		Y/N	N
monthly reset: Yearly reset:						
Power input: Total reset:	R/W	Bb	Reset total power consumption count		Y/N	N
C-day reset:	R/W	Bb	Reset day power consumption count		Y/N	N
C-night reset:	R/W	Bb	Reset night power consumption count		Y/N	N
Total Delta efficiency reset:	R/W	Bc	Total Delta efficiency reset		Y/N	N
Date of last maintenance:	R/W	Bd	Set last maintenance date day month year		(1,31) (0,23) (0,99)	

Freon type:	R/W	Bd	Set freon		5		Probe calibration
Unit type:	R/W	Bd	Set board type details		MT / LT		
Probes calibration: Suction :	R/W	Be	Suction probe calibration	bar	-9.9 , 9.9	0	Device output manual forcing
Probes calibration: Discharge	R/W	Be	Discharge probes calibration	bar	-9.9 , 9.9	0	
Probe setting: Gas	R/W	Bf	Gas probe calibration	ppM	-9.9 , 9.9	0	
Probe setting: ext	R/W	Bf	Outside probe calibration	°C	-9.9 , 9.9	0	
Manual operation - duration	R	Bg	Display. Manual device operation		Y/N	N	
max 5 minutes							
Comp.1:N Stat.: (compres.1,2,...,6)	R/W	Bh,Bi,...Bm	Manual operation of compressor 1,2,...,6		Y/N	N	
Step1:N Stat.:	R/W	Bh,Bi,...Bm	Manual operation by steps compressor 1,2,...,6		Y/N	N	
Parz.2:N Stat.:	R/W	Bh,Bi,...Bm	Manual operation by steps compressor 1,2,...,6		Y/N	N	
Parz.3:N Stat.:	R/W	Bh	Manual operation by steps of compressor 1		Y/N	N	
Manual operation: Fans.1,2,...,16: Status	R/W	Bn,Bo	Manual operation of fans 1,2,...,16		Y/N	N	
COMP. On manual Comp. inverter:	R/W	...Bq Br	Inverters can be forced to 100% (MANU.) or to zero (AUTO.)		AUTO	AUTO	
Inverter fans:	R/W	Br	Inverters can be forced to 100% (MANU.) or to zero (AUTO.)		/MAX AUTO	AUTO	
Enter new password:	R/W	Bs	Enter a new maintenance password		/MAX 0 , 9999	0	Maintenance password

Programming screen

System

Parameter	Type	Pos.	DESCRIPTION	U. of M.	Range	Default value	TN	BT
Enter PROGRAM key – programming branch P0,P1,...,Pj								
Enter user password:	R/W	P0	Enter user password		0 , 9999	0	0	
Current language: ITALIAN press ENTER key to change	R/W	P1	Based on the configuration installed, the language used on the screens can be changed (ITALIAN, ENGLISH, FRENCH, GERMAN, SPANISH)		5 Languages		1 (Italian)	
bar/°C change set-point	R/W	Pq	Configure the setpoint in degrees centigrade or pressure				bar	
Compressor Setpoint limit	R/W	P2	Upper and lower limit of the compressor setpoint	bar / °C	(-95,95) o (-5,+70)	2.5	4,7 (-2)	1,5 (-25)
Max				bar / °C	(-95,95) o (-5,+70)	0.1	2.4 (-17)	0,3 (-40)
Fan Setpoint limit	R/W	P3	Upper and lower limit of the fan setpoint	bar / °C	(-95,95) o (0,+30)	1.0	10 (+20)	
Max				bar / °C	(-95,95) o	25.0	17 (+40)	

Dead zone cut-in time max time min time	R/W	PL	Set the maximum and minimum time for the cut-in calls for compressors in dead zone	s	(0,+30) 0.....9999	60	20	240 120	180 90
Dead zone cut-in time max time min time	R/W	PM	Set the maximum and minimum time for the cut-out calls for compressors in dead zone	s	0.....9999	60	10	60	15 40 5
Diff. Dead zone Pressure range in which time varies	R/W	PN	Pressure differential in which compressor on/off time is proportional to suction pressure position	bar	0.....99,9		0,5	0,5	0,3
Alarm delay generic input	R/W	Po	Generic/compressor thermal overload alarm delay	s	0.....99		0	90	90
Oil differential delay alarm Start:	R/W	P4	Delay of oil differential alarm (if configured) Alarm timing on compressor start	s	0 ... 360		120	/	
Oil differential delay alarm Running:	R/W	P4	Oil differential alarm delay (if configured) alarm times with compressor in stable operation	s	0 ... 99		10	/	
Alarms relay delay:	R/W	P5	Change in alarm relay status delay	s	0.....999		1	900	
LP auto->man change 5 alarms within:	R/W	P5	On the fifth activation, within the set time, the low pressure alarm from pressure switch changes from automatic to manual reset	min	0.....999		10	10	
Suction press. alarm Thresh. A.:	R/W	P6	Suction probe alarm: high threshold setting	bar / °C	(-95..95) o (- 5..+70)		4.0	5,0 (0)	2,0 (-20)
Differ. :	R/W	P6	Suction probe alarm: differential setting	bar / °C	0.....99,9		0.5	0,5 (3K)	0,3 (2K)
Delay:	R/W	P6	Suction probe alarm: delay setting	s	0 ... 9999		1	1800	
Suction press. alarm Thresh. B.:	R/W	P7	Suction probe alarm: low threshold setting	bar / °C	(-95..95) o (- 5..+70)		0.5	1,5 (25)	0,2 (-42)
Differ. :	R/W	P7	Suction probe alarm: differential setting	bar / °C	0.....99,9		0.5	0,5 (3K)	0,3 (2K)
Delay:	R/W	P7	Suction probe alarm: delay setting	s	0 ... 9999		1	300	
Disch. press. alarm Thresh. A.:	R/W	P8	Discharge probe alarm: high threshold setting	bar / °C	(-95..95) o (0,+30)		20.00	22,0 (+50)	
Differ. :	R/W	P8	Discharge probe alarm: differential setting	bar / °C	0...99.9		1.0	1,0 (2K)	
HP Prev Time prevent 1:	R/W	P9	The time in which cut-in calls after a prevent cycle has occurred	min	0...99		6	5	
HP Prev Time prevent 2:	R/W	P9	If two prevent cycles occur within this time, an excessive prevent frequency alarm is generated	min	0...9999		6	10	
HP Prev Time prevent 3:	R/W	P9	If no prevent alarms are activated in this period, the excessive prevent frequency alarm is reset automatically	min	0...99		30	30	
Disch. press. alarm Thresh. B.:	R/W	Pa	Discharge probe alarm: low threshold setting	bar / °C	(-95..95) o (0,+30)		2.0	5,0 (0)	
Differ. :	R/W	Pa	Discharge probe alarm: differential setting	bar / °C	0...99.9		1.0	0,5 (2,5K)	
Delay:	R/W	Pa	Discharge probe alarm: delay setting	s	0 ... 999		1	60	
Liquid level al. Delay:	R/W	Pb	Liquid level alarm delay	s	0...9999		90	1800	
Alarm gas detec. Threshold:	R/W	Pc	Refrigerant leak detector alarm threshold	ppM	99.9..99.9		50.0	50	
Alarm gas detec. Different.:	R/W	Pc	Refrigerant leak detector alarm differential	ppM	9.9...9.9		2.0	2.0	
Delay:	R/W	Pc	Refrigerant leak detector alarm delay	min	0...99		3	3	
Blackout startup delay enabled:	R/W	Pd	Enable delay at start-up after blackout.		Y/N		N	N	
Delay time:	R/W	Pd	Used to diversify the start times with multiple units, when power returns after a blackout	S	0...9999			-	
Switch OFF unit OFF by supervisor:	R/W	Pe	Enable ON/OFF from supervisor		Y/N		N	N	
Disconnected probe:	R/W	Pe	Enable Off from disconnected probe		Y/N		N	N	
Elect. input start sampling Daily, minutes	R/W	Pf	Set daily power consumption sampling, hours, minutes, monthly		(0..23)		23	-	
Monthly					(0..59) (0..31)			-	
Power input Start sampling yearly:	R/W	Pg	Set yearly power consumption sampling		1,12		12	-	

Power input	R/W	Ph	Set power consumption sampling, start time		0,23	8	-
Start daily zone							-
Minutes	R/W		minutes to end		0,59	0	-
End daily zone:	R/W	Ph	Set power consumption sampling, end time		0,23	20	-
Minutes	R/W		minutes to end		0,59	30	-
Evaporator Evap. Temp.	R/W	Pi	Evaporator evaporating temperature		-99,9, Set. comp °C	-265	-
Evap.Delta efficiency	R/W	Pi	Evaporator efficiency	%	0,99	3	-
Condenser cond Temp.	R/W	Pj	Condenser condensing temperature		Set fans °C,999	430	-
CondDelta efficiency	R/W	Pk	Efficienza condensatore	%	0,99	2	-
Enter new password:	R/W	Pk	Enter a new user password		0,9999	0	-

Configuration screen

System

Parameter	Type	Pos.	DESCRIPTION	U. of M.	Range	Default value	TN	BT
<p>Press MENU+PROGRAM key, the cursor will already be in the CONFIGURATION chain; press ENTER, the cursor will already be on DEVICES, press ENTER: you can now view the branch C1,2,...,Ch</p>								
Enter manufacturer password:	R/W	C0	Enter manufacturer password		0,9999	0	0	
Type of safety devices per compressor	R/W	C3	Set the type of safety devices per compressor:		4	1	1 (generic)	
			1-Generic, 2-Thermal overload + Oil differential, 3- Thermal overload + High/low pressure switch 4: Thermal overload + High/low pressure switch + Diff. Oil					
Config. number of fans:	R/W	C4	Set number of fans		0-16	4	2=2 fans 3=3 fans 4=4 fans	
Config. number of compressors:	R/W	C4	Set number of compressors		0,6	3	3=3 compr. 4=4 compr. 5=5 compr.	
Config. number of Load steps:	R/W	C4	Set load steps		0,3	0	0	
Non configurable compressor inverters	R/W	C5	Enable compressor inverters if configured without load steps		Y/N	N	N	
Enable fan Inverter:N Y1=t	R/W	C5	Enable control of fans with inverters		Y/N	S	N	
Enable alarm relay:	R/W	C6	Enable alarm relay		Y/N	S	Y	
Enable clock card:	R/W	C6	Enable clock card if pCO1		Y/N	S	Y	
Enable inputs Gen. pressure switch HP : gen.HP:	R/W	C7	Enable inputs: System-protection low-pressure switch (automatic –reset) and high-pressure switch (manual reset)		Y/N	S	Y	
Enable ON/OFF inputs from Dig. Input :	R/W	C3	Enable ON/OFF of units from digital input, has priority over that of keypad		Y/N	N	N	
Liquid level alarm:	R/W	C6	Enable liquid level alarm from digital input (display only).		Y/N	S	Y	
Enable inputs Common oil diff.	R/W	CK	Enable common oil differential alarm		Y/N	N	N	
Enable inputs Com. fan thermal overload	R/W	CK	Enable common fan thermal overload alarm (display only).		Y/N	N	N	
Enable inputs Setpoint change from DIN	R/W	CK	Enable change of setpoint from digital input. The setpoint changes depending on the offsets entered on the		Y/N	N	N	

		screens Sb, Sc					
Enable electronic expansion valve:	R/W	C9	Enable expansion with the help of the electronic valve		Y/N	N	N
Type of NTC suction probe:	R/W	Ca	Defines type of suction probe Carel NTC temperature probes, (50÷100 °C; R/T 10KW a 25°C), voltage (0-1)V, (0-10)V current (0-20)mA, (4-20)mA			(4-20)mA	4-20mA
input no. B1	R/W	Ca	Sets position of the suction probe: B1 o B7 solo per schede Medium o Large	Y/N	N		N
Type of NTC discharge probe:	R/W	Cb	Defines type of discharge probe Carel NTC temperature probes, (50÷100 °C; R/T 10KW a 25°C), voltage (0-1)V, (0-10)V current (0-20)mA, (4-20)mA			(4-20)mA	4-20mA
input no. B2	R/W	Cb	Sets position of the discharge probe: B2 or Bx only for Medium or Large boards		Y/N	N	N
Suction pressure probe min.value:	R/W	Cc	Suction probe full scale setting	bar	-10.0,40.0	-5	-1
Max :	R/W	Cc	Suction probe full scale setting	bar	-10.0,40.0	70	9
Discharge pressure probe min. value:	R/W	Cd	Discharge probe full scale setting	bar	-10.0,40.0	0	-1
Max :	R/W	Cd	Discharge probe full scale setting	bar	-10.0,40.0	300	19
Enable probes: B3 Room temp. :	R/W	Ce	For enabling external temperature probes		Y/N	N	N
B6 Outside Temper.:	R/W	Ce	For enabling external temperature probes		Y/N	N	N
B7 settable:	R/W	Ce	For enabling external temperature probes		Y/N	N	N
B3 Power input:	R/W	Cf	For enabling probe B3 for power consumption		Y/N	N	N
Min :	R/W	Cf	Probe full scale setting		0,999	0	-
Max :	R/W	Cf	Probe full scale setting		0,200,0	200	-
B7 Gas detector	R/W	Cg	For enabling probe B7 for refrigerant gas detection		Y/N	S	N
Min :	R/W	Cg	Setting scale max. and min. limits		-99.9,99.9	0	-
Max :	R/W	Cg	Setting scale max. and min. limits		-999.9,999.9	90	-
Freon type:	R/W	Ch	Type of refrigerant used: R22, R134a, NH3, R404a, R407C, R410A o nessuno di questi tipi		7	r134a	r404a

Input configuration screens							System	
Parameter	Type	Pos.	DESCRIPTION	U. of M.	Range	Default value	TN	BT
<p>Press keys MENU+PROGRAM, the cursor will already be in the CONFIGURATION chain; press ENTER, place the cursor on the INPUT POSITION CHAIN, press ENTER; using UP/DOWN it is possible to scroll the screens in branch D1,D2,...,Dd</p>								
Card Pos. Thermal overload comp 1,2,...,6	R/W	D0,D1,...,D5	Position of digital inputs used as safety devices compressor 1,2,...,6		0,23			
Oil Diff. comp. 1,2,...,6	R/W	D0,D1,...,D5	Position of digital inputs used as safety devices compressor 1,2,...,6		0,23			
Pres.HL.	R/W	D0,D1,...,D5	Position of digital inputs used as safety devices compressor 1,2,...,6		0,23			
Comp. 1,2,...,6 Card Pos.	R/W	D6,D7,...,Da	Position of digital inputs used as safety devices fans 2,...,16		0,23			
Thermal overload fans 1,2,...,16								
Card Pos. ON / OFF %	R/W	Db	Position of the ON/OFF digital input on the card Parametri visibili solo se abilitati.		0,23			
Card Pos.: Liquid level	R/W	Dc	Position of the liquid level alarm on the card. Parameter		0,23			

alarm: Card Pos. Gen. LP pressure switch: Gen. HP pressure switch:	R/W	Dd	can be seen only if enabled. Position of high and low pressure switches on the card. Parameter can be seen only if enabled.		0,23			
Output configuration screens							System	
Parameter	Type	Pos.	DESCRIPTION	U. of M.	Range	Default value	TN	BT
Press keys MENU+PROGRAM, the cursor will already be in the CONFIGURATION chain; press ENTER, place the cursor on the OUTPUT POSITION CHAIN, press ENTER; using UP/DOWN it is possible to scroll the screens in branch E1,E2,...,Ed								
Comp.1,2,...,6 Relay no.:	R/W	E1,E2 E5	Position of high and low pressure switches on the card. digital output compressor 1,2,...,6		0,(8-13-8)			
Load step 1-C1,2,...,6 Relay no.:	R/W	E1,E2 E5	Position of load step 1 of compressor 1,2,...,6 digital outputs on the card		0,(8-13-8)			
Load step 2-C1,2,...,6 Relay no. 0:	R/W	E1,E2 E5	Position of load step 2 of compressor 1,2,...,6 digital outputs on the card		0,(8-13-8)			
Load step 3-C1,2,...,6 Relay no.:	R/W	E1,E2 E5	Position of load step 3 of compressor 1,2,...,6 digital outputs on the card		0,(8-13-8)			
Card Pos. Fans 1,2,...,16 Relay no.:	R/W	E6,E7 Ea	Position of digital outputs on the card. fans 1,2,...,16		0,(8-13-8)			
Card Pos. Alarm relay n°:	R/W	Ed	Position of the alarm digital output on the card		0,(8-13-8)			
General settings:							System	
Parameter	Type	Pos.	DESCRIPTION	U. of M.	Range	Default value	TN	BT
Press keys MENU+PROG; using the UP/DOWN keys go to the PARAMETERS chain and press ENTER								
Logic:Digital inputs N/A = no alarm	R/W	G0	Digital input logic setting. Normally open: the contact is open in non-alarm conditions		N.A./N.C	N.C.	N.C.	
Logic ON/OFF from digital input	R/W	G1	Remote ON/OFF logic setting. Normally open: unit in OFF position from digital input.		N.O./N.C	N.O.	N.O.	
Type of reset for pressure-switch alarm A/B single compresso:	R/W	G2	Type of high/low pressure switch reset for single compressor. Automatic: al cessare dell'allarme il compressore riparte. Visibile se i parametri sono abilitati		AUTOMATIC/MANUAL	MANUAL	AUTOMATIC	
High Prevent	R/W	G3	Enables suction high pressure prevention		DISABLED/ENABLED	ENABLED	ENABLED	
Discharge pressure	R/W	G3	Enables high suction pressure prevention	bar	0,99	18	18	
Alarm relay logic:	R/W	G4	Alarm relay logic. Can be seen if the alarm relay is enabled.		NORMALLY CLOSED/OPEN	NORMALMENTE CHIUSO	NORMALLY CLOSED	
Comp. rotation	R/W	G5	Enabling FIFO rotation first in first out) for compressors.		LIFO.FIFO, timer controlled	FIFO	FIFO	
Set. PROPORTIONAL BAND for comp.	R/W	G5	Type of control to be used with compressor management: Proportional band or Dead Zone		Proportional band/dead band	Dead zone	DEAD ZONE	
Type of control Compressors:	R/W	G6	This screen can only be viewed if the compressor setting is Proportional band. Tipo di regolazione da seguire: (P) Proporzionale o (P+I) Proporzionale è integrale.		P / P+I	P	P	
Integr. time (only P+I)	R/W	G6	Integral time of P+I control	s	0,999	600	-	
Comp. start mode :CppCppCpp	R/W	G7	Compressors start mode CppCppCpp = fully start one compressor at a time CCCppppppp= start first all		CppCppCpp / CCCppppppp	CppCppCpp	-	

Comp. Switch off mode:ppCpCpCpC	R/W	G7	Compressors and then all load steps Compressors switch off mode CppCpCpCp = fully start one compressor at a time CCCppppppp= start first all compressors and then all load steps		CppCpCpCp / CCCppppppp	CppCpCpCpCp	-
Load steps logic:	R/W	G8	Sets whether the load step solenoids are: normally energised (closed), de-energised (open).		NORMALLY CLOSED / OPEN	NORMALLY CLOSED	-
Minimum compressor inverter opening:	R/W	G9	Minimum inverter opening setting: This screen can only be seen if inverters are enabled	%	0,99.9	0	-
Fans:	R/W	G9	Minimum inverter opening setting:	%	0,99.9	0	-
PWM speed controller Max. Triac:	R/W	Ga	When controller pCO1 is used and PWM outputs are enabled this Triac Max screen can be seen: triac voltage to fan electric motor is minimum speed. This does not correspond to effective voltage applied but to a calculation unit from pCO1.	%	0,100	75	-
Triac min.:	R/W	Ga	Min Triac setting: triac voltage to fan electric motor is minimum speed. This does not correspond to effective voltage applied but to a calculation unit from pCO1.	%	0,100	25	-
Pulse amplitude:	R/W	Ga	Sets pulse amplitude that stands for triac pulse duration: this represents the triac applied pulse duration in milliseconds	ms	0,10.0	2.5	-
Number of compressors forced on with probe fault:	R/W	Gb	If there is a faulty or disconnected suction probe alarm, it forces no. compressors that are on. They are in any case controlled by single alarms and by general pressure switches.		0,6	1	0
Fan rotation DISABLES	R/W	Gc	Enabling FIFO rotation first in first out) for fans.		Disabled /FIFO	Disabled	FIFO
Control type PROPORTIONAL BAND	R/W	Gc	Type of control to be used with fan management: Proportional band or Dead Zone		Proportional band/dead band	Proportional band	DEAD ZONE
Number of fans forced on with probe fault:	R/W	Gd	If there is a faulty or disconnected discharge probe alarm, it forces no. fans that are on. They are in any case controlled by single alarms and by general pressure switches.		0...16	2	0
Type of general discharge pressure switch reset:	R/W	Ge	Type of general high pressure switch reset		AUTOMATIC / MANUAL	2	AUTOMATIC

General settings

Parameter	Type	Pos.	DESCRIPTION	U. of M.	Range	Default value	System	
							TN	BT
Press keys MENU+PROG; using the UP/DOWN keys go to the TIMES chain and press ENTER								
Time between compr. Switch on requests :	R/W	T0	These parameters are visible when the compressor setting is dead band control. Time between compressor switch-on requests	s	0,999	20	60	40
Time between compr. Switch off requests :	R/W	T1	Time between compressor switch-off requests (dead band or proportional band prevent)	s	0,999	10	20	15
Min. compressor on time :	R/W	T2	Minimum On time of same compressor	s	0,9999	10	90	
Min. compressor off time :	R/W	T2	Minimum Off time of same compressor	s	0,9999	120	120	
Min. time between switch-ons of different compressors:	R/W	T3	Minimum time between two ON requests of different compressors. They prevent simultaneous starts.	s	0,9999	20	20	
Min. time between switch-ons of same compressor:	R/W	T4	Minimum time between two actual power ups of same compressor	s	0,999	360	360	
Delay of load steps on power up:	R/W	T5	This parameter can only be seen is load steps are configured. Delay between the request and actual switch-on of load steps	s	0,999	20	-	
Time between fan switch-on requests :	R/W	T6	Minimum time between two switch-ons of same fan	s	0,999	2	30	
Time between fan switch-off requests :	R/W	T6	Minimum time between two switch-offs of same fan	s	0,999	2	30	
Fans minimum time between different switch ons:	R/W	T7	Minimum time between two fan switch-on request. They prevent simultaneous starts.	s	0,999	5	5	

General settings:

Press keys **MENU+PROG**, using the **UP/DOWN** keys go to the **INITIALIZATION chain** and press **ENTER**

Parameter	Type	Pos.	DESCRIPTION	U. of M.	Range	Default value	System	TN	BT
Supervisor Communication speed	R/W	V0	Supervisor configuration. Speed of communication with the supervision system.	baud	0,5	19200	-	-	-
Identification:	R/W	V0	Supervisor configuration. Sets the identification number of the pCO ² card for the serial supervision network.		1,200	1	-	-	-
Type of protocol:CAREL SUPERVISOR	R/W	V1	Protocol type setting: CAREL Supervisor, Modbus Supervisor or GSM Modem		1,3	Carel supervisor	-	-	-
New manufacturer password:	R/W	V2	Allows to change the password for entering the manufacturer branch		0,9999	1234	-	-	-
Maintenance:	R/W	V2	Allows to change the password for entering the maintenance branch		0,9999	0	-	-	-
User:	R/W	V2	Allows to change the password for entering the user branch.		0,9999	0	-	-	-
Display the	R/W	V3	Position Y views the language change screen on startup. Position N does not view the language change screen on startup	On/Off	Y/N	Y	-	-	-
Change message: Language on startup									
Installation of default values:	R/W	V4	Allows to delete all of the permanent memory and reset the default settings N.B. It is advisable to effect this when the machine is off.	On/Off	Y/N	N	-	-	-

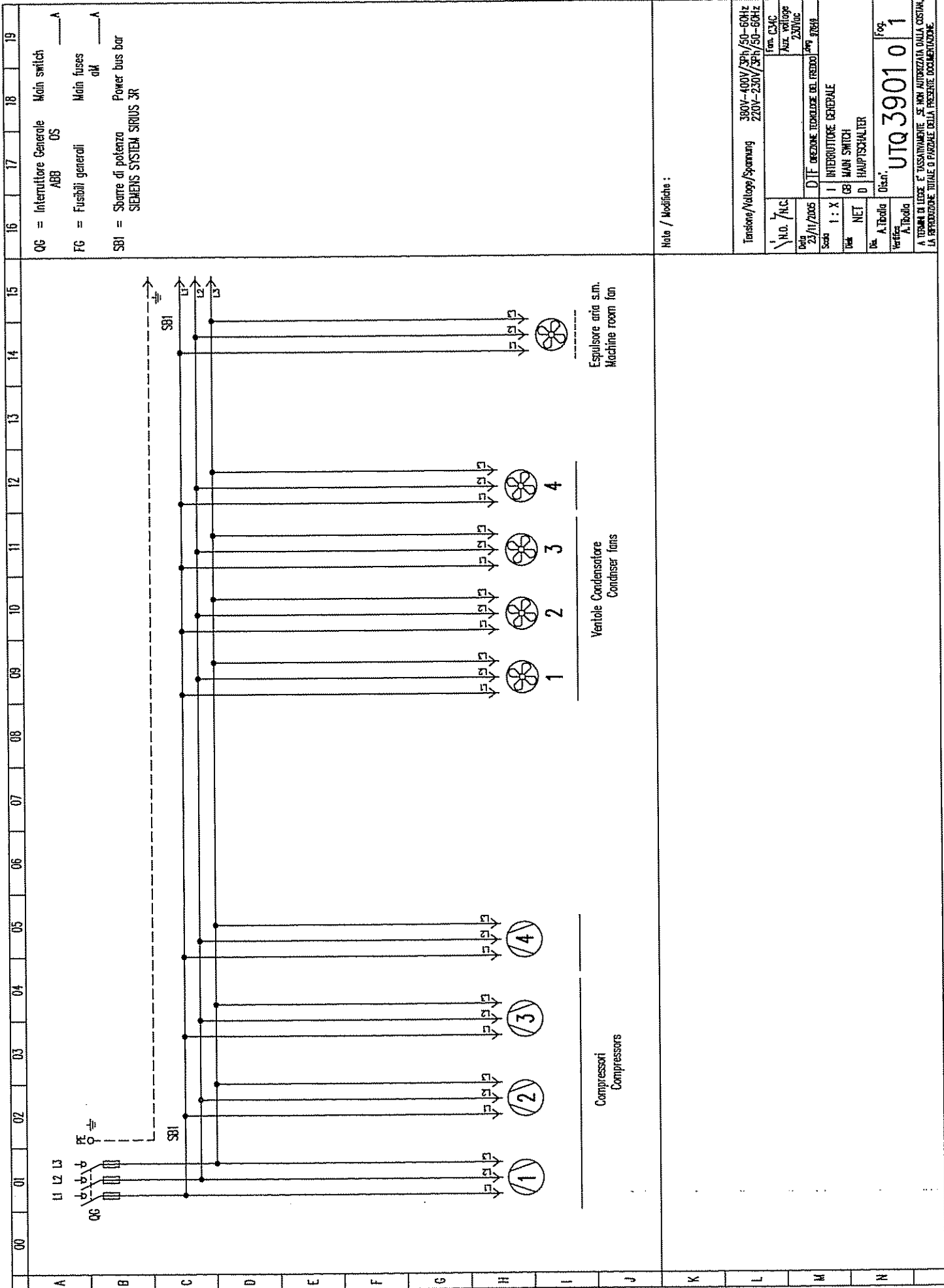

Note / Modifiche :

A TEMPI DI LIEVE È TASSATIVAMENTE SE NON AUTORIZZATA DALLA COSTRAZIONE, LA RIPRODUZIONE TOTALE O PARZIALE DELLA PRESENTE DOCUMENTAZIONE.

16	17	18	19
F1 = Fusibile trasformatore LEGRAND 05828 10,3x38 cm 10A	Trasformatore LEGRAND	Transformer fuses 10,3x38 cm 10A	Transformer VA
TR =	SB2 =	Transformer	Auxiliary Bus Bar 04881
Tensione/Voltage			
300-400V/3Ph/50-60Hz		220-230V/3Ph/50-60Hz	
REGOLAZIONE USCITA 230V / OUT 230V REGULATION			
SETTAGGIO USCITA 230V SETTING OUT 230V SET AUSGANG 230V			

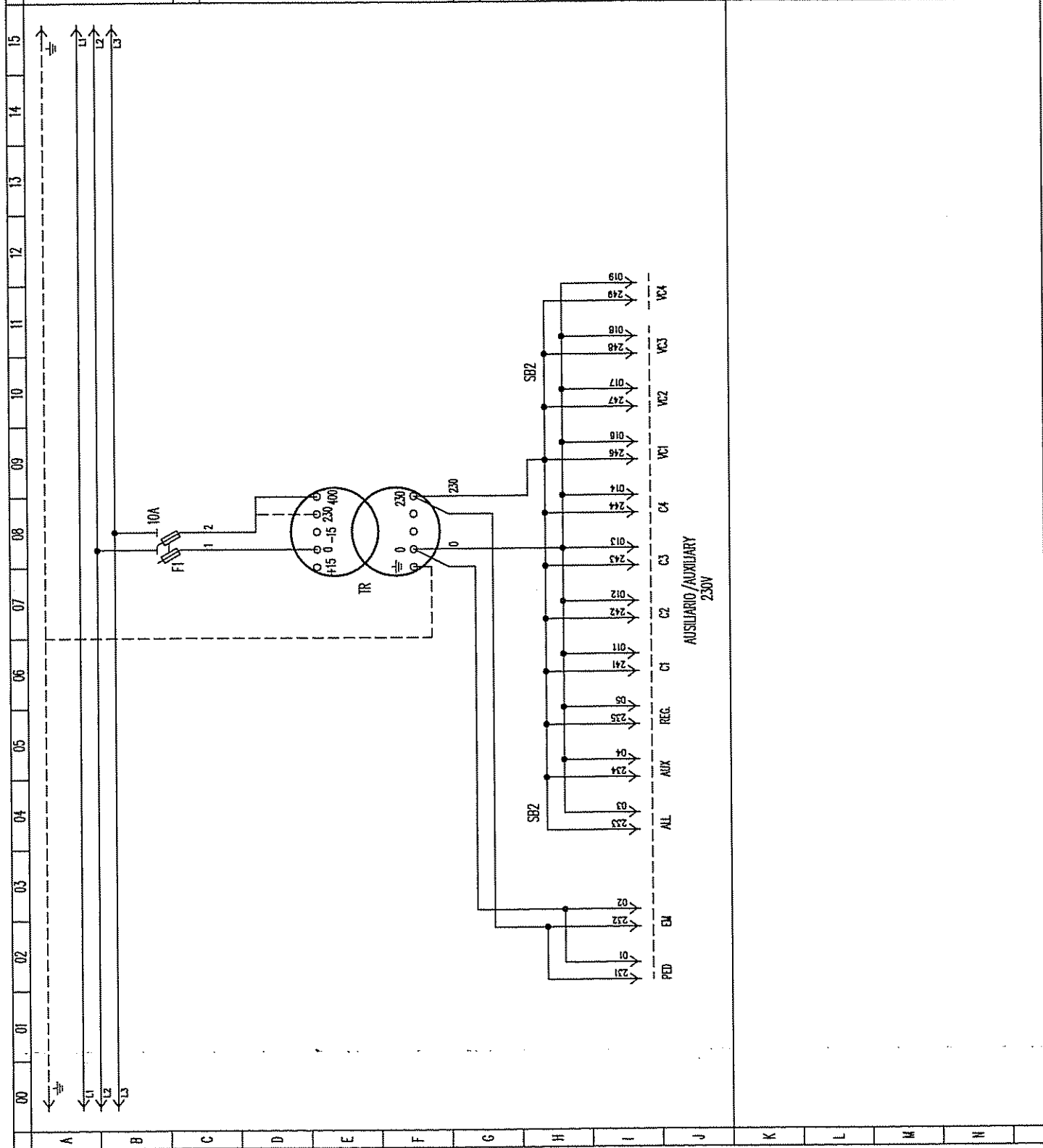

Note / Modifiche :

Tensione/Voltage / Spannung		380V-400V/3Ph/50-60Hz 220V-230V/3Ph/50-60Hz	
N.O. / N.C.		Fem. C34C	
Aux. voltage		230Vdc	
Data		23/IV/2005	
Scale		1 : X	
Dis. NET		D	
Dis. A.T.Bole		Dis. A.T.Bole	
Verifica A.T.Bole		Verifica A.T.Bole	
Dis. n°		Dis. n°	
Fog.		Fog.	
UTQ39020		UTQ39020	
A TERMINI DI LEGGE E' TASSATIVAMENTE SE' PER AUTORIZZAZIONE DELLA COSTRA, LA RIPRODUZIONE TOTALE O PARZIALE DELLA PRESENTE DOCUMENTAZIONE.			

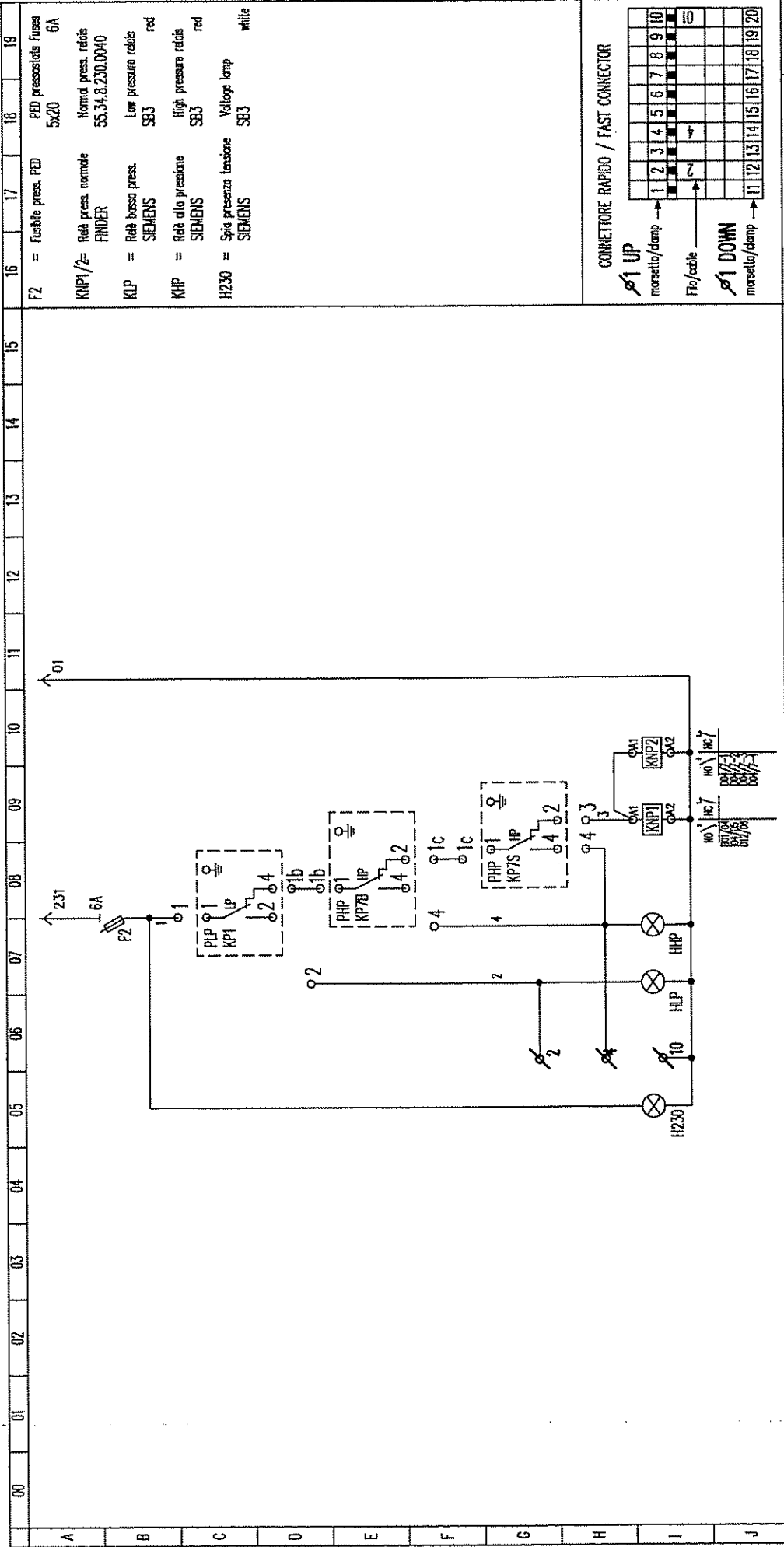

F2 = Fusibile press. PED 5x20 6A	16	17	18	19
KNP1/2= Rete press. normale FINDER	1	2	3	4
KLP = Rete bassa press. SIEMENS	5	6	7	8
KHP = Rete alta pressione SIEMENS	9	10	11	12
H230 = Spia presenza tensione SIEMENS	13	14	15	16
	17	18	19	20

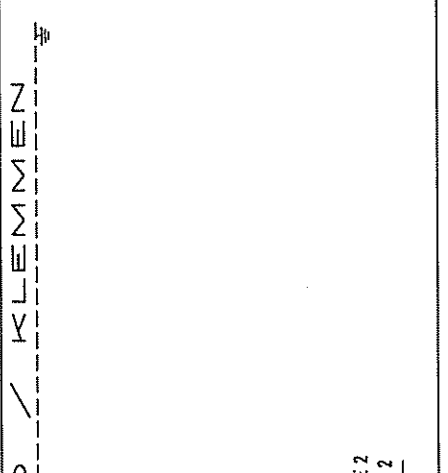

NO. INC. / 6874/0074
n. leg. / n. leg.

Tensione / Voltage / Spannung 380V-400V / 3PH / 50-60HZ
220V-230V / 3PH / 50-60HZ

NO. / N.C. / n.c.
230V ac

Data 23/11/2005

Descr. D.I.C. DIVISIONE IMPANTI/CENTRALI

Spec. 1: X 1 PRESSOSTATO SICUREZZA PED

Det. NET 03 SECURITY PRESSOSTAT PED

Disct. 0 SICHERHEIT DRUCK BREKRENER PED

Verf. A. Tardio

UTQ39030

A TUTTA LA LEGGE E' ASSUMIBILE SE NON AUTORIZZATI DALLA ORIGINALI
LA RIPRODUZIONE TORNE O PRONE DELLA PRESENTE DOCUMENTAZIONE.

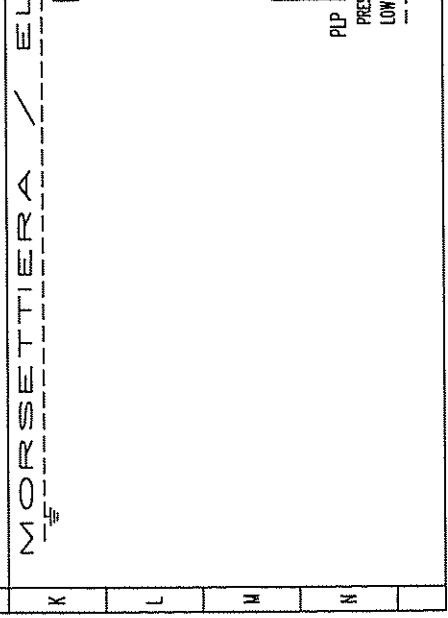

60	01	02	03	04	05	06	07	08	09	10	11	12	13	14	15	16	17	18	19
A	B	C	D	E	F	G	H	I	J	K	L	M	N						
F3/5 = Fusibili ausiliari 4A 2A		Auxiliary fuses		F4 = Relè ausiliari FINDER 55.34.8.230.0040		Auxiliary relays		RO = Ritardatore scaricca FINDER 80.11.8.240		Security Timer		40 MIN.		RI/3 = Ritardatori compr. 2-5 FINDER 80.11.8.240		Timer compr. 2-5 1-2-3 MIN.			

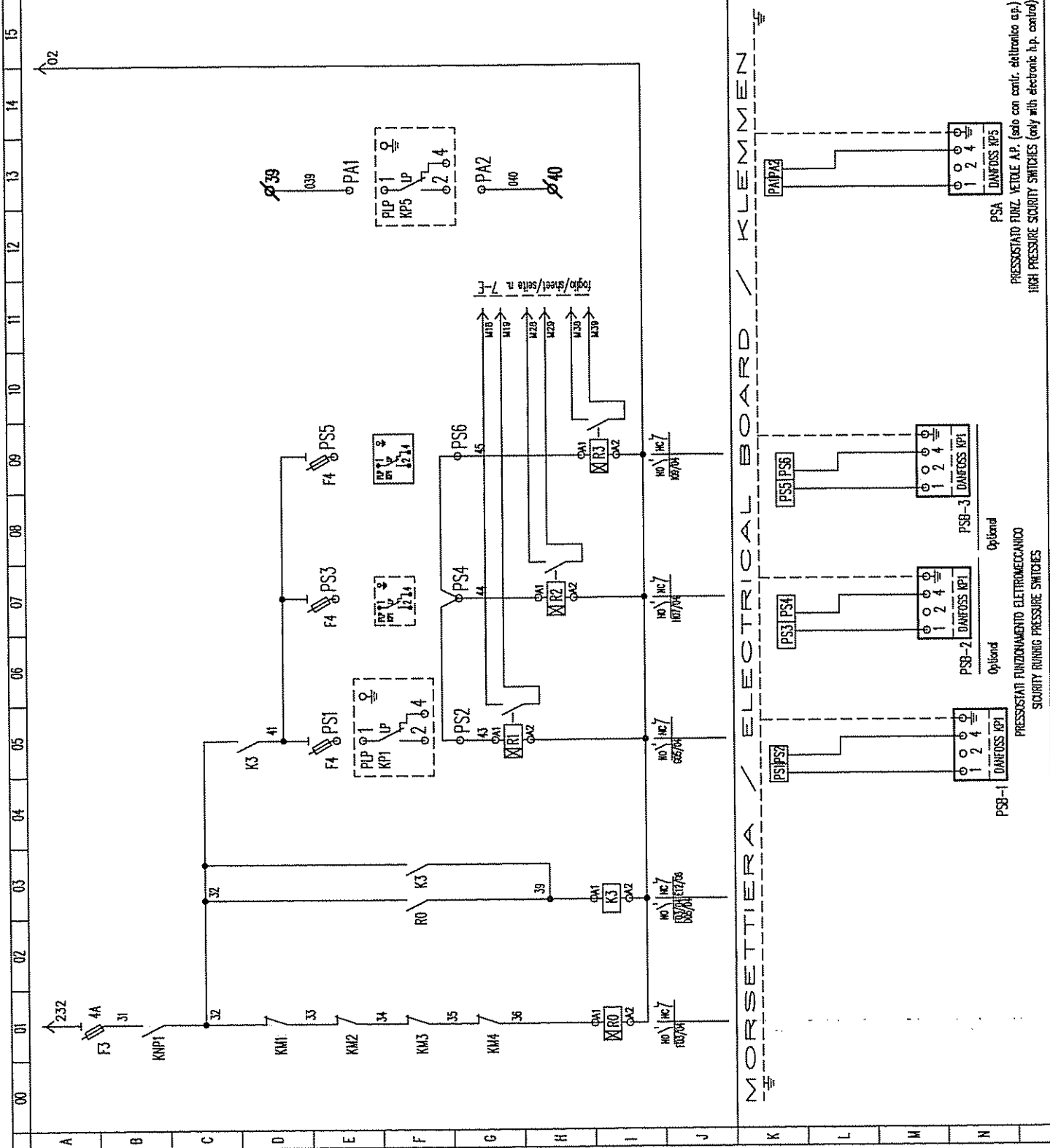

MORSETTIERA / ELECTRICAL BOARD / KLEMMEN-
 PSA-DANFOSS RP1
 PSA-DANFOSS RP1
 PSA-DANFOSS RP1
 PSA-DANFOSS RP1
 PSA-DANFOSS RP1
 PSA-DANFOSS RP1

Note / Modifiche :

NO. INC. 1007/00704
 data di revisione n. 004

Tensione/Voltage/Spannung 380V-400V/3Ph/50-60Hz
 220V-230V/3Ph/50-60Hz

NO. INC. 1007/00704
 data di revisione n. 004

Form. C34C
 Aux. voltage 230Vacc

D.I.C. DISTRIBUZIONE IMPIANTI CENTRALI S.p.A. 37049

Scale 1 : X
 DSK NET

Verifica A. Todiola
 DSK NET
 D ELETTRISIDE SICURETTEI NEIDERBUCK
 DSK NET

UTQ 39040 4
 fog.

A TORNARE DI LEGGE È NECESSARIAMENTE SE NON AUTORIZZATA DALLA DGSIA,
 LA RIPRODUZIONE TOTALE O PARZIALE DELLA PRESSIONE DOBBIERUNTORE.

Optional
 PRESSOSTATI FUNZIONAMENTO ELETTROMECCANICO
 SECURITY RUNNING PRESSURE SWITCHES

Optional
 PRESSOSTATI FUZZ. VELELE A.P. (solo con contr. elettronico a.p.)
 HIGH PRESSURE SECURITY SWITCHES (only with electronic h.p. control)

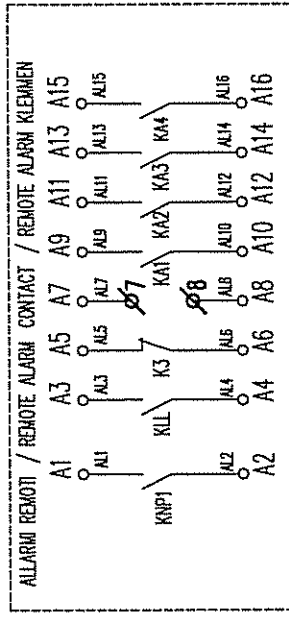
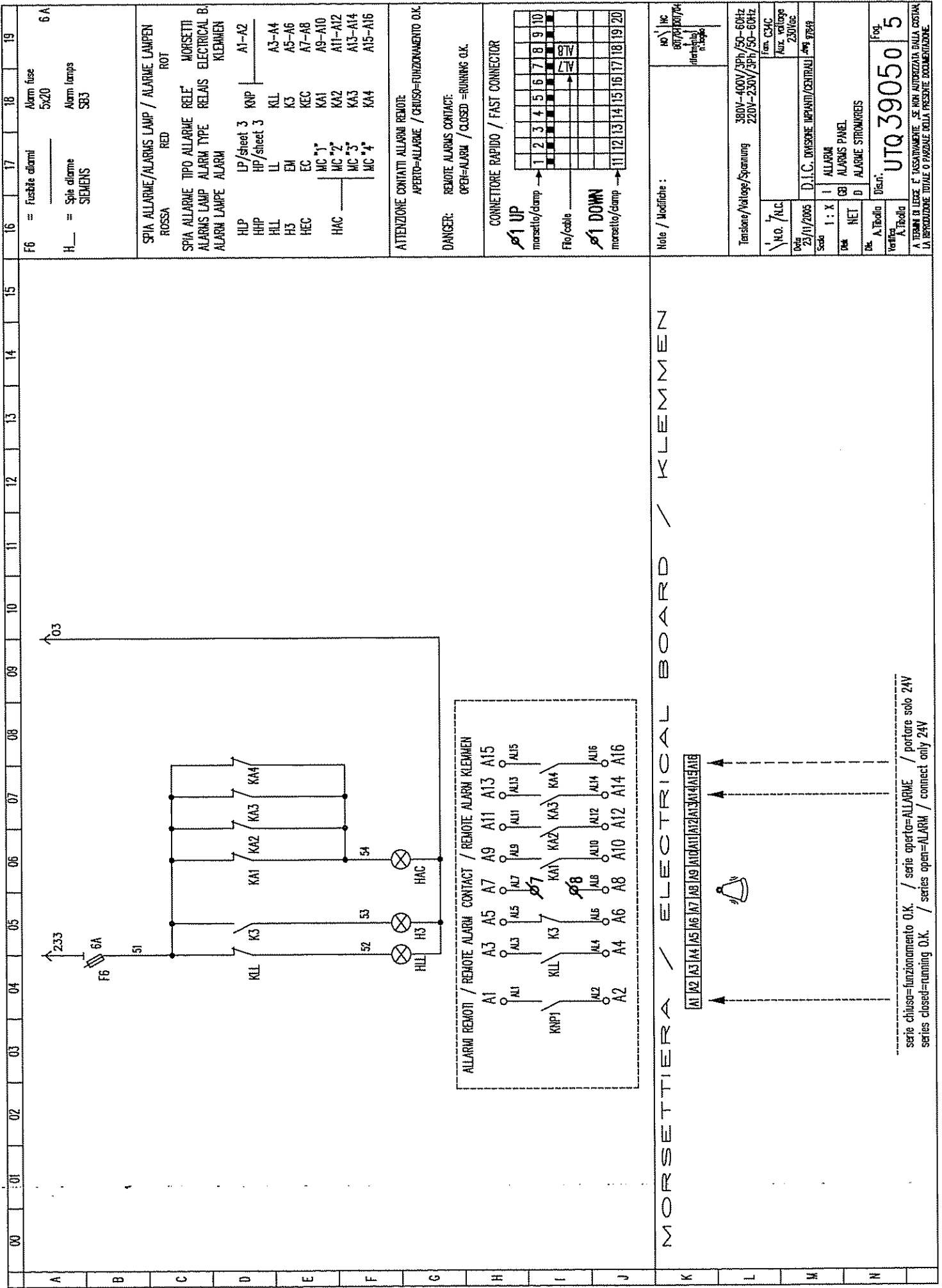

MORSETTIERA / ELECTRICAL BOARD / KLEMMEN

A1 A2 A3 A4 A5 A6 A7 A8 A9 A10 A11 A12 A13 A14 A15 A16

serie chiuso=funzionamento O.K. / serie aperto=ALLARME / portore solo 24V
 series closed=running O.K. / series open=ALARM / connect only 24V

F6 = Fusibile allarmi Alarm fuse 5x20 6A
 H_ = Spie allarme SIEMENS Alarm lamps SB3

SPIA ALLARME/ALARM LAMP / ALARME LAMPEN ROSSA RED ROT
 MORSETTI
 ALARMS LAMP ALARM TYPE RELAIS ELECTRICAL B. KLEMMEN
 LP/sheet 3 KNP A1-A2
 HP/sheet 3 KLL A3-A4
 LL EM K3 A5-A6
 EC KEC A7-A8
 MC "1" KA1 A9-A10
 MC "2" KA2 A11-A12
 MC "3" KA3 A13-A14
 MC "4" KA4 A15-A16

ATTENZIONE CONTATTI ALLARMI REMOTE APERTO=ALARME / CHIUSO=FUNZIONAMENTO O.K.
 DANGER: REMOTE ALARMS CONTACT: OPEN=ALARM / CLOSED =RUNNING O.K.

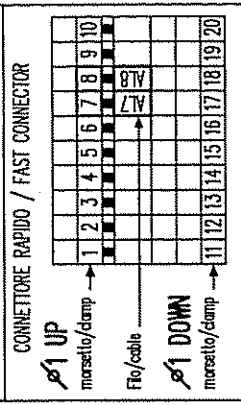

Note / Modifiche : NO INC 80724/80704 (intermittent stop)

Tensione/Voltage/Spamnung 380V-400V/3Ph/50-60Hz 220V-230V/3Ph/50-60Hz
 I.N.O. / N.C. from CSFC
 Aux. voltage 230Vacc
 Data 23/11/2005 D.I.C. DIVISIONE IMPANTI/CENTRALI
 Scala 1 : X ALLARME ALARMS PANEL ALARME STROMREIS
 Verifica A.Tibollo
 Fog. UTQ39050 5

A TERMI DI LEGGE E' ASSOLUTAMENTE SE NON AUTORIZZATA NELLA COSTRUI LA RIPRODUZIONE TOTALE O PARZIALE DELLA PRESENTE DOCUMENTAZIONE.

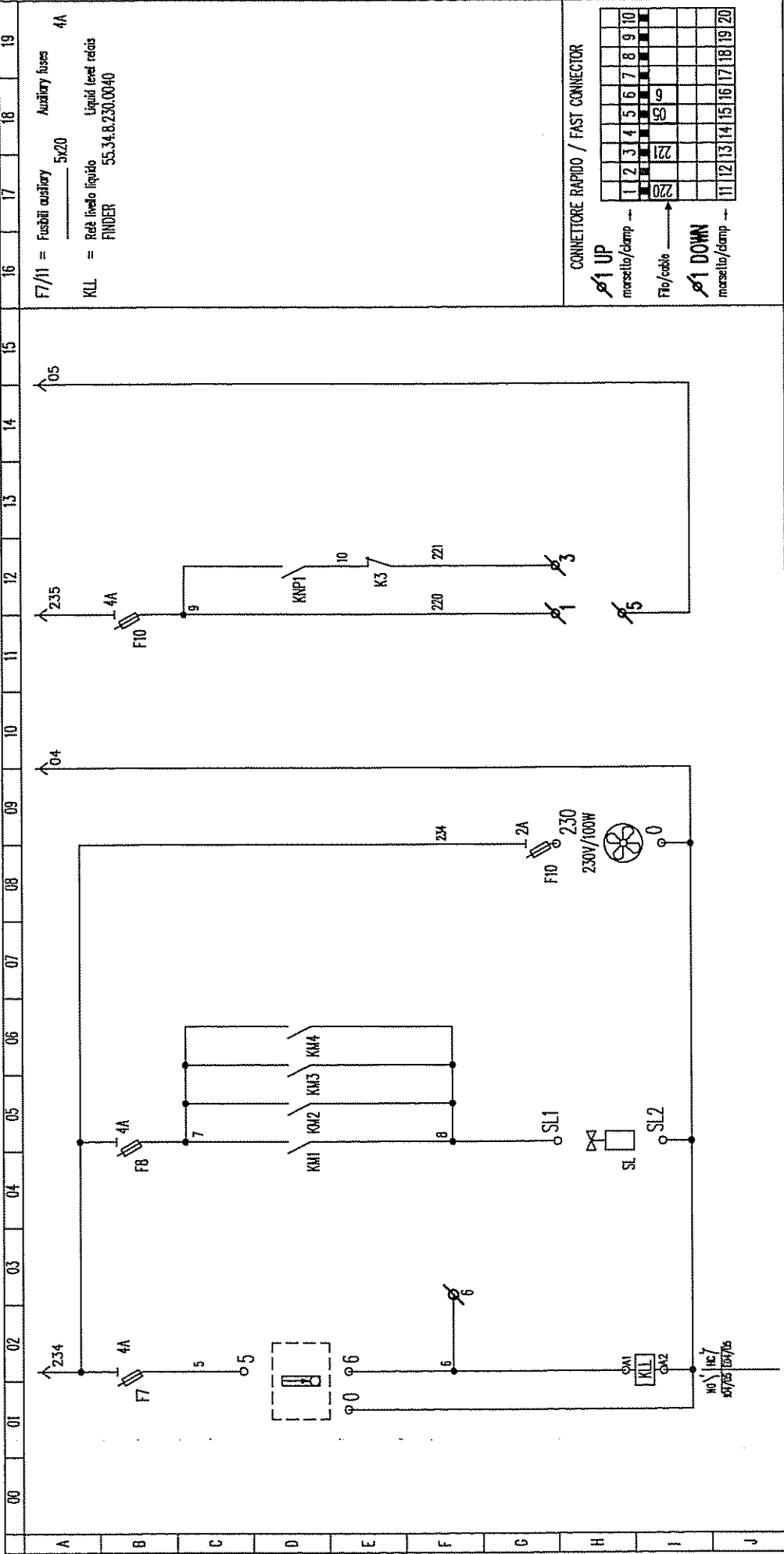

MORSETTIERA / ELECTRICAL BOARD / KLEMMEN

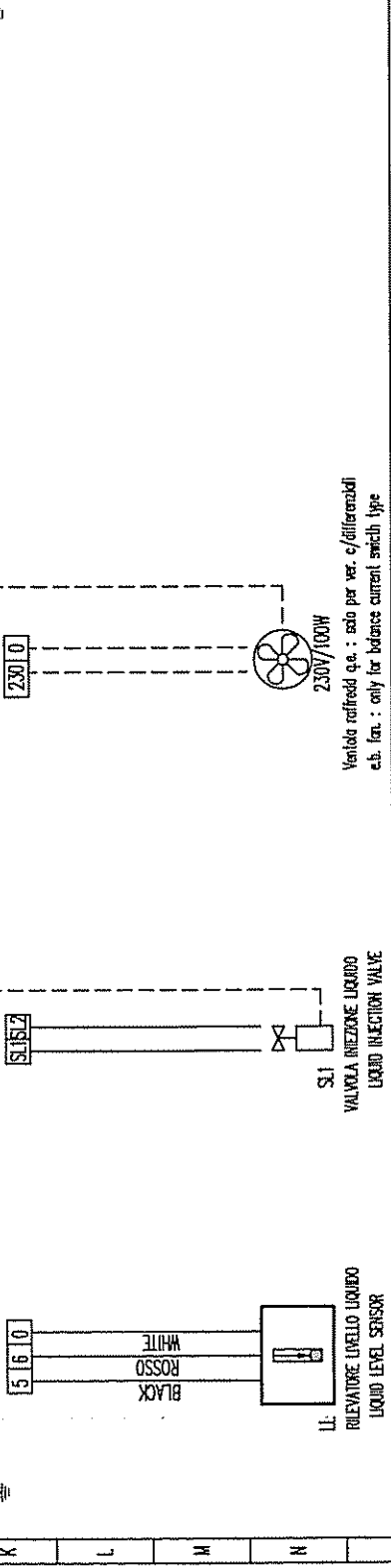

F7/F1 = Fusibili auxiliary
Auxiliary fuses 4A

KLL = Rete livello liquido
Liquid level relais
FINDER 55.34.8.230.0040

CONNETTORE RAPIDO / FAST CONNECTOR

	1	2	3	4	5	6	7	8	9	10
↙ UP morsello/clamp --							22	23		
Filo/cable										
↘ DOWN morsello/clamp --	11	12	13	14	15	16	17	18	19	20

Note / modifiche:

no. mc / 67708/707/4
materiale n. foglio

Tensione/Voltage/Spannung 380V-400V/3Ph/50-60Hz
220V-230V/3Ph/50-60Hz

fem. C.S.A.C.
Aux. voltage 230Vcc

Orig 23/11/2005 D.I.C. DIVISIONE IMPIANTI/CENTRALI pag. 97/98

Scala 1: X I LIVELLO/VALVINEZIONE LIQUIDO/SERVOI AUX. 230V
68 I LIQUID LEVEL/VALVINECTON V/AUXILIARY 230V

Dist. NET D I KKL/LEVEL RELAIS / 230V STRONGERS

Disegn. A. Tedolin Fog. 6

Verifica A. Tedolin

UTQ 39060

A TERMINI DI LEGGE È TASSATIVAMENTE SE NON AUTORIZZATA DALLA COST/EN LA REPRODUZIONE TOTALE O PARZIALE DELLA PRESENTE DOCUMENTAZIONE.

Ventole raffredd c.a. : solo per ver. c/differenziali
c.b. fan. : only for balance current switch type.

VALVOLA INIEZIONE LIQUIDO
LIQUID INJECTION VALVE

LL:
RELEVATORE LIVELLO LIQUIDO
LIQUID LEVEL SENSOR

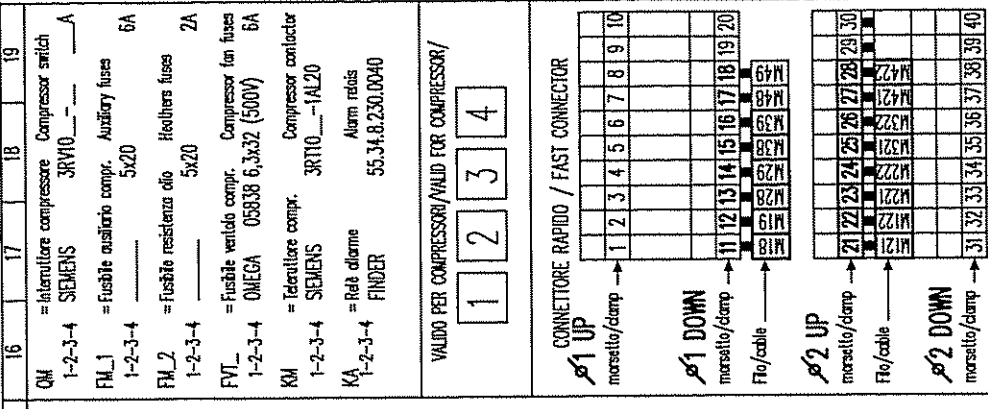

16	17	18	19
QM	= Interruttore compressore	Compressor switch	
1-2-3-4	SIEMENS	3RT10	___
FM_1	= Fusibile ausiliario compr.	Auxiliary fuses	
1-2-3-4	___	5x20	6A
FM_2	= Fusibile resistenza olio	Heaters fuses	
1-2-3-4	___	5x20	2A
FVT_	= Fusibile ventola compr.	Compressor fan fuses	
1-2-3-4	OMEGA	05838 6,3x32 (500V)	6A
KM	= Interruttore compr.	Compressor contactor	
1-2-3-4	SIEMENS	3RT10	___-1AL20
KA	= Relè di ampiezza	Alarm relays	
1-2-3-4	FINDER	55.34.8.230.0040	
VALIDO PER COMPRESSORI/VALID FOR COMPRESSOR/ 1 2 3 4			

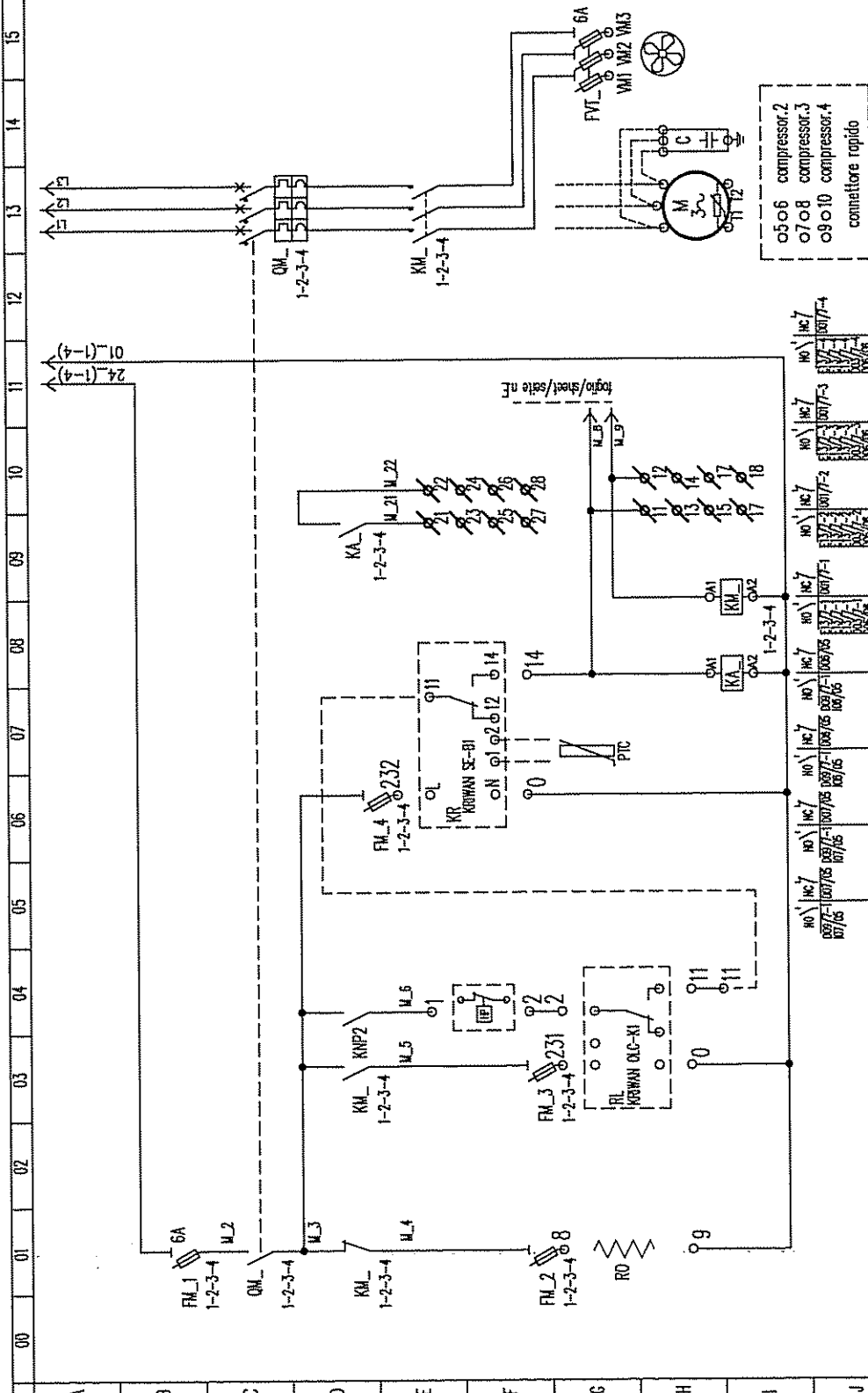

Tensione/Voltage/Spinning		380V-400V/2Ph/50-60Hz	220V-230V/3Ph/50-60Hz
Aux. voltage		1 from C34C	
Date		23/11/2005	
Scale		1 : X	
Dis.		D.I.C. DIVISIONE IMPIANTI/CENTRAU. any 878P	
Titolo		CONTROLLO COMPRESSORE	
Verifica		COMPRESSOR CONTROL PANEL	
Disegn.		VEROCHIEF STEUERUNG STROMKREIS	
Foglio		7	

MORSETTIERA / ELECTRICAL BOARD / KLEMMEN

UTQ39070

A TORNARE IN LUOGO LE ASSIEME SE NON INTERFERENZA ALLA COSTR. LA RIPRODUZIONE TOTALE O PARZIALE DELLA PRESENTE DOCUMENTAZIONE.

16	17	18	19
QV 1-2-3-4 SIEMENS	= Interr. ventile FANS SWITCH	3RV	A
FV 1-2-3-4	= Fusibile aux. ventile Auxiliary fuses	5x20	4 A
KV 1-2-3-4	= Interruttore ventile FANS CONTACTOR	3RT	

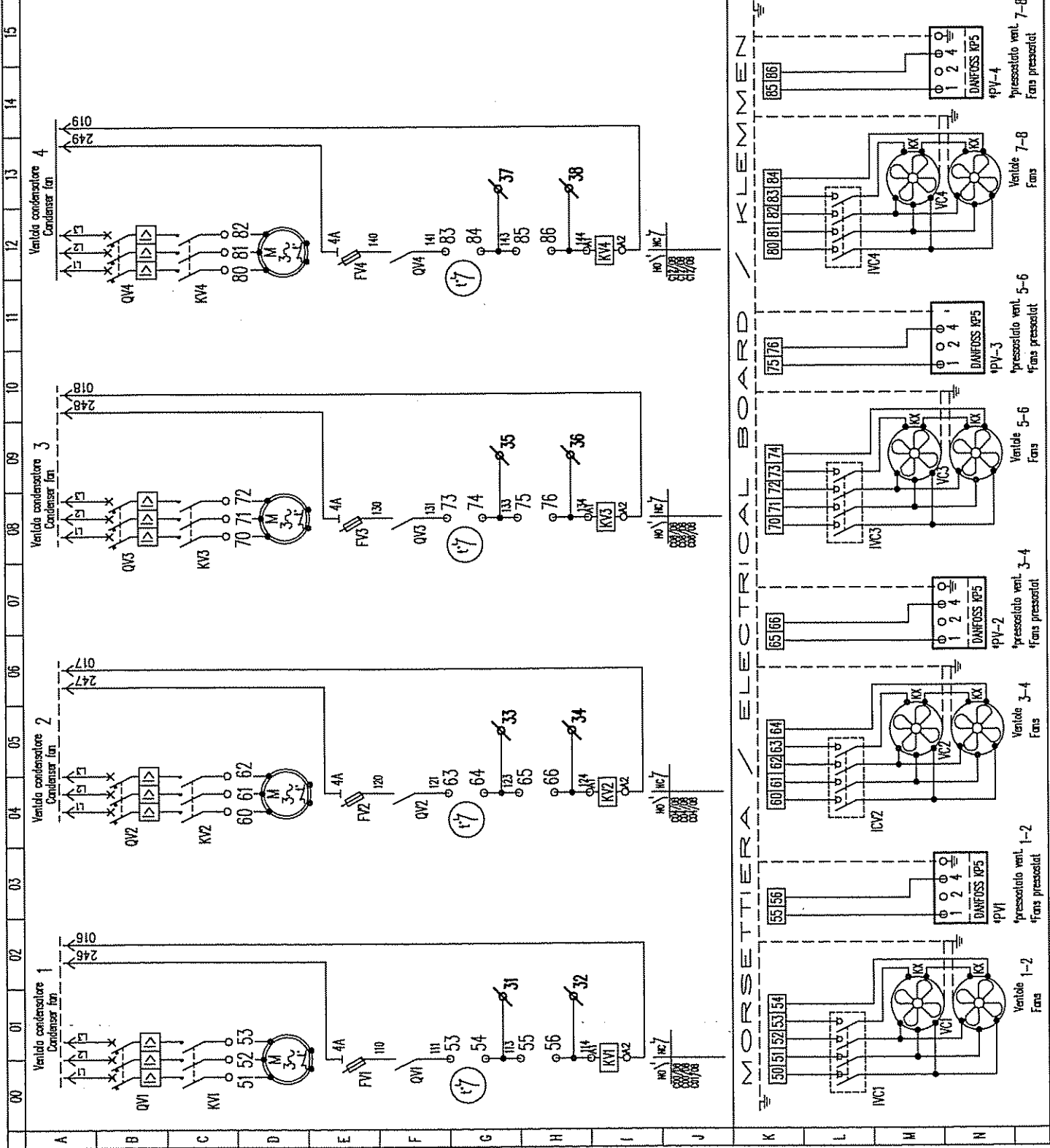

00	01	02	03	04	05	06	07	08	09	10	11	12	13	14	15
A	B	C	D	E	F	G	H	I	J	K	L	M	N		

CONNETTORE RAPIDO / FAST CONNECTOR

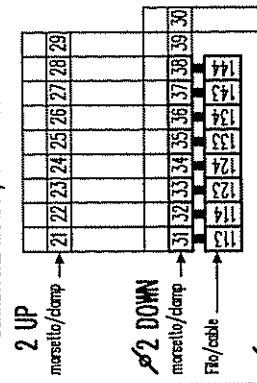

NOTE / Modifiche :

- *PV-4 pressostati comando ventile
- *Collegare i pressostati KPS solo per regolatori senza controllo dell'olio pressione
- *PV-4 fans pressostats
- *Connect the pressure switch KPS only in the case with controller without high pressure control

INC 1-4= INTERRUVENTOLA
FANS SWITCH
KQ= KUKON TERMICA VENTOLA
KUKON FANS THERMIC PROTECTOR

Nota / Modifiche :

NO	INC
60/70/80/90	
100/110/120	

Tensione/Voltage/Spornung 380V-400V/3Ph/50-60Hz
220V-230V/3Ph/50-60Hz

Im. CSAC
Aux. voltage 230VAC

DATA	23/VI/2005	DIF	DIREZIONE TERMICHE DEL FREDDO	FR58
SOLO	I : X	I	VENTOLE CONDENSATORE	
DEK	NET	B1	CONDENSER FAN	
INT.	A.100/110	D	CONDENSATOR LIQUITER	
VERIFICA	Al.Bozza	Dis. n°		
				Fog. 8

UTQ 39180

A TUTTAVIA SI LEGGE E' NECESSARIAMENTE SE NON AUTORIZZATA DALLA DISTRIB. LA REPRODUZIONE TOTALE O PARZIALE DELLA PRESENTE DOCUMENTAZIONE.

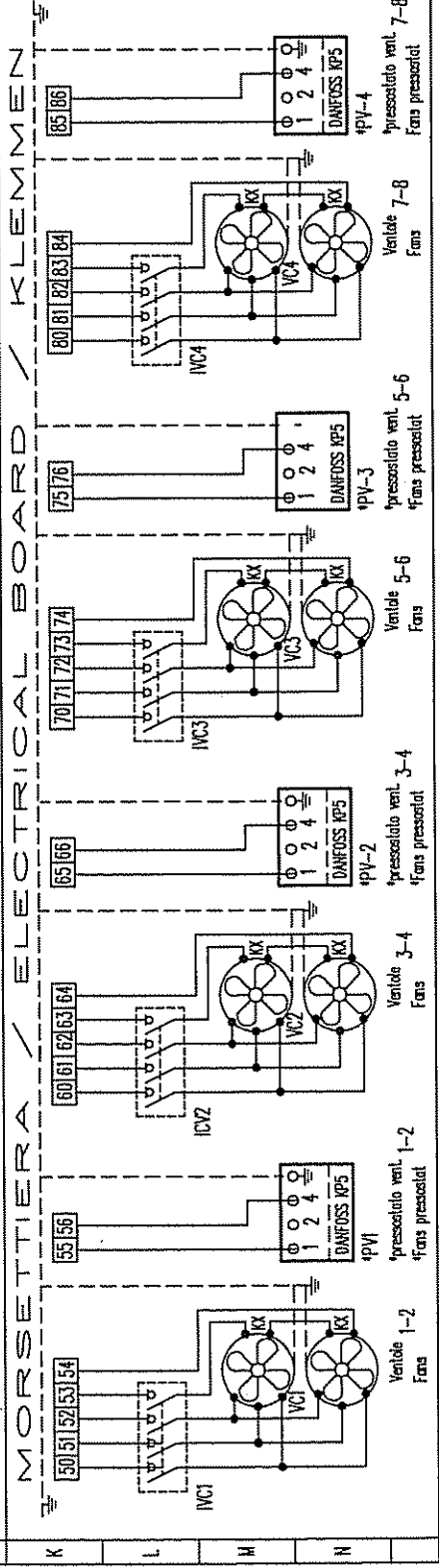

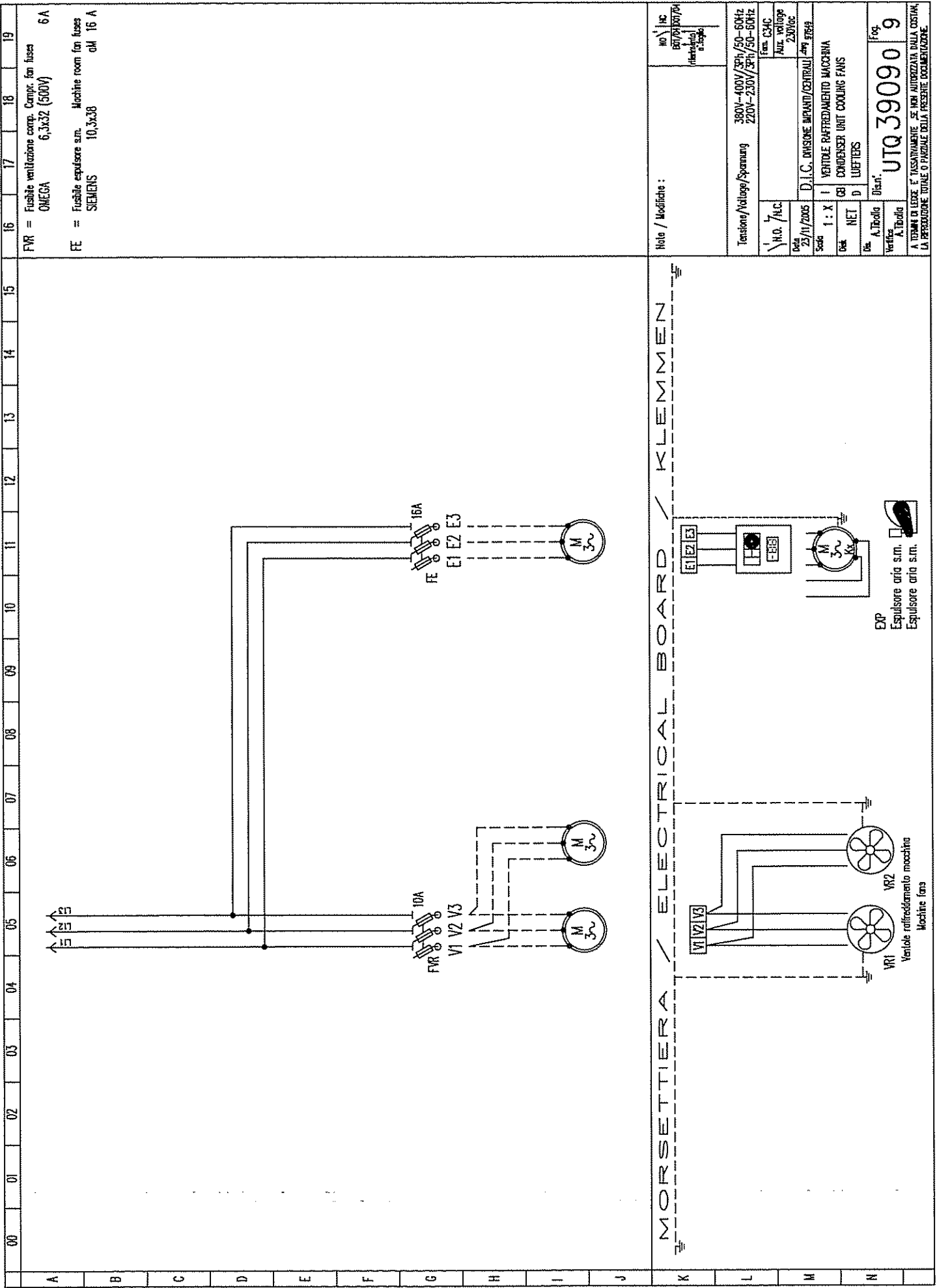

F16 = Fusibile ventilazione comp. Comp. fan fuses
 OMEGA 6,3x32 (500V) 6A

F17 = Fusibile espulsore a.r. Machine room fan fuses
 SIEMENS 10,3x38 16 A

16 Note / Modificato:

Tensione/Voltage/Spannung	380V-400V/3PH/50-60Hz 220V-230V/3PH/50-60Hz
U.O. /AC	Fan C34C
Aut. voltage	230V/CC
22/11/2005	D.I.C. DIVISIONE IMPIANTI CENTRALI 400V 50/60Hz
Scala	1 : X
Doc	VENTOLE RAFFREDDAMENTO MACCHINA CONDENSER UNIT COOLING FANS
Dis.	NET
Verifica	Ustan'
A.Tibollo	
Fog.	9

UTQ 39090

A TERMI DI LEGGE E' TASSATIVAMENTE SE NON AUTORIZZATA DALLA COSTRA, LA PRESSIONE TOTALE O PARZIALE DELLA PRESENTE DOCUMENTAZIONE.

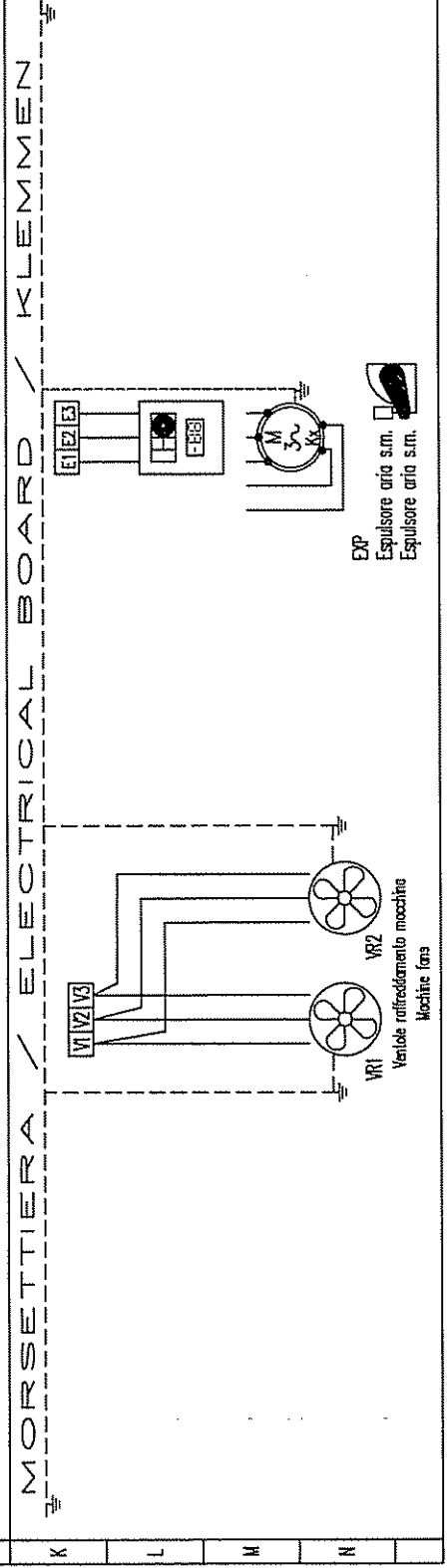

MORSETTIERA / ELECTRICAL BOARD / KLEMMEN

19

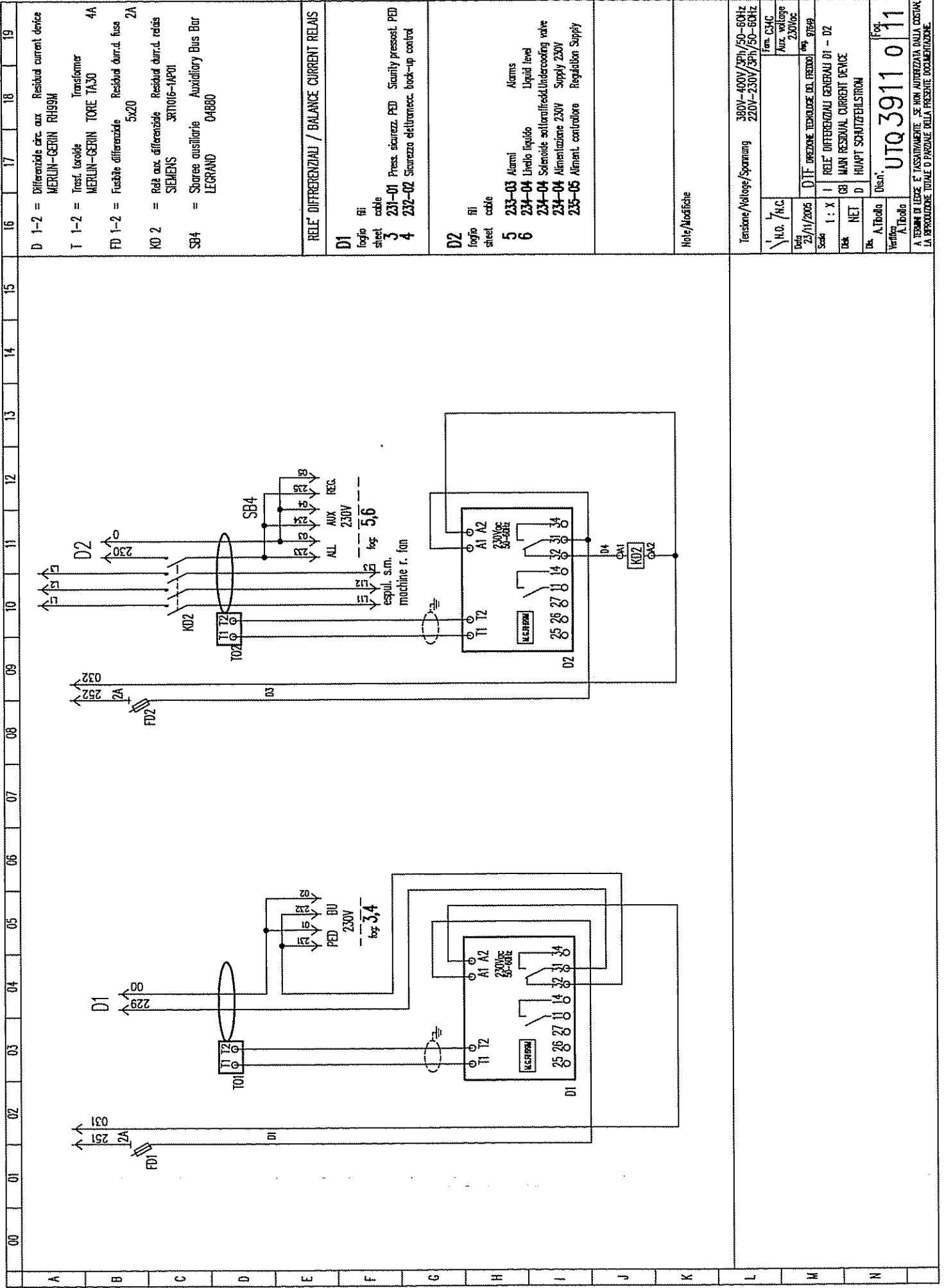

- D 1-2 = Differenziale circ. aux Residual current device
MERLIN-GERIN RH99M
- T 1-2 = Trasn. toroide Transformer
MERLIN-GERIN TORE TA30 4A
- FD 1-2 = Fusibile differenziale Residual curr.d. fuse
5x20 2A
- K0 2 = Relè aux. differenziale Residual curr.d. relais
SIEMENS 3RT1016-1AP01
- SB4 = Sbarre ausiliarie Auxiliary Bus Bar
LEGRAND 04880

RELE' DIFFERENZIALI / BALANCE CURRENT RELAYS

D1
foglio sheet 3
cable 231-01
street Press. sicurezza PED Safety pressost. PED
4 232-02 Sicurezza elettronicc. lock-up control

D2
foglio sheet 5
cable 233-03
street Alarmi Alarms
6 234-04 Livello liquido Liquid level
234-04 Solenoide sottomarinoUndercooing valve
234-04 Alimentazione 230V Supply 230V
235-05 Aliment. controllore Regulation Supply

Help/Modifiche

Tensione/Voltage/Spamnung		380V-400V/3Ph/50-60Hz
N.D. / n.c.		220V-230V/3Ph/50-60Hz
Data		25/11/2005
Tem. C3MC		230Vacc
Aux. voltage		230Vacc
DIF PREZIONE TEMPERATURE DEL FREDDO		
Scale	1 : X	I RELE' DIFFERENZIALI GENERALI D1 - D2
Tab.	NET	GB MAIN RESIDUAL CURRENT DEVICE
Da	A.Troalla	D HAUPT SCHUTZLEISTRON
Verifica	A.Troalla	
Disegn. UTQ3911 011		
A. TROALLA E. LEZZI F. LASCARINELLI SE NON AUTORIZZATA DALLA COFINA LA RIPRODUZIONE TOTALE O PARZIALE DELLA PRESENTE DOCUMENTAZIONE.		

00 01 02 03 04 05 06 07 08 09 10 11 12 13 14 15 16 17 18 19

DM 1-4 = Differenziale comp. MERLIN-GERIN RHB9M
 TM 1-4 = Trasn. Ioroid MERLIN-GERIN TORE TA30 4A
 FDM 1-4 = Fusibile differenziale Residual durr.d. fuse 5x20 2A
 QM 1-4 = Interruttore compressore Compressor switch bobina di spiarico off bobbin SIEMENS 3RV1902-IDPO

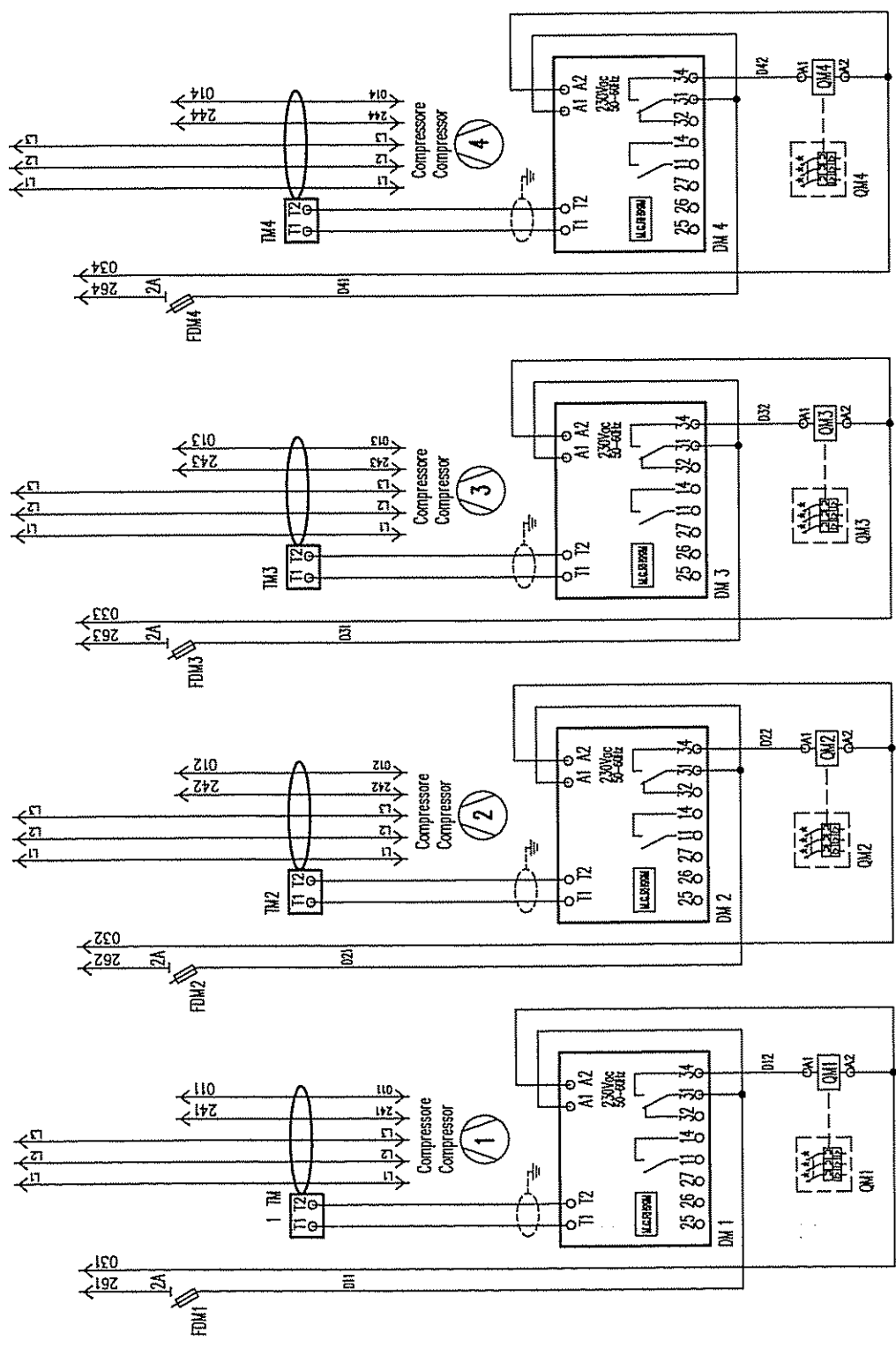

siglature / setting
 Compressore / Compressor
 1 2 3 4

Note/Modifiche
 01-06-2005: Sostituzione di R4328A con R499M

Tensione/Voltage/Spannung	380V-400V/3Ph/50-60Hz 220V-230V/3Ph/50-60Hz
H.Q. / n.c.	
Data	23/11/2005
Scale	1 : X
Desc	NET
Dis.	A. Tibolla
Verifica	A. Tibolla
DIF. DIREZIONE TECNOLOGIE DEL FREDDO, n. 97649 RELE DIFFERENZIALI COMPRESSORI COMPRESSOR RESIDUAL CURRENT DEVICE VERRICHTER FELDSTROM RELAIS Dis. n.	
Fog. 12 UTQ 39120	
A. TERREMI IN LEGGE E' TASSATIVAMENTE SE NON AUTORIZZATA DALLA GERMA, LA RIPRODUZIONE TOTALE O PARZIALE DELLA PRESENTE DOCUMENTAZIONE.	

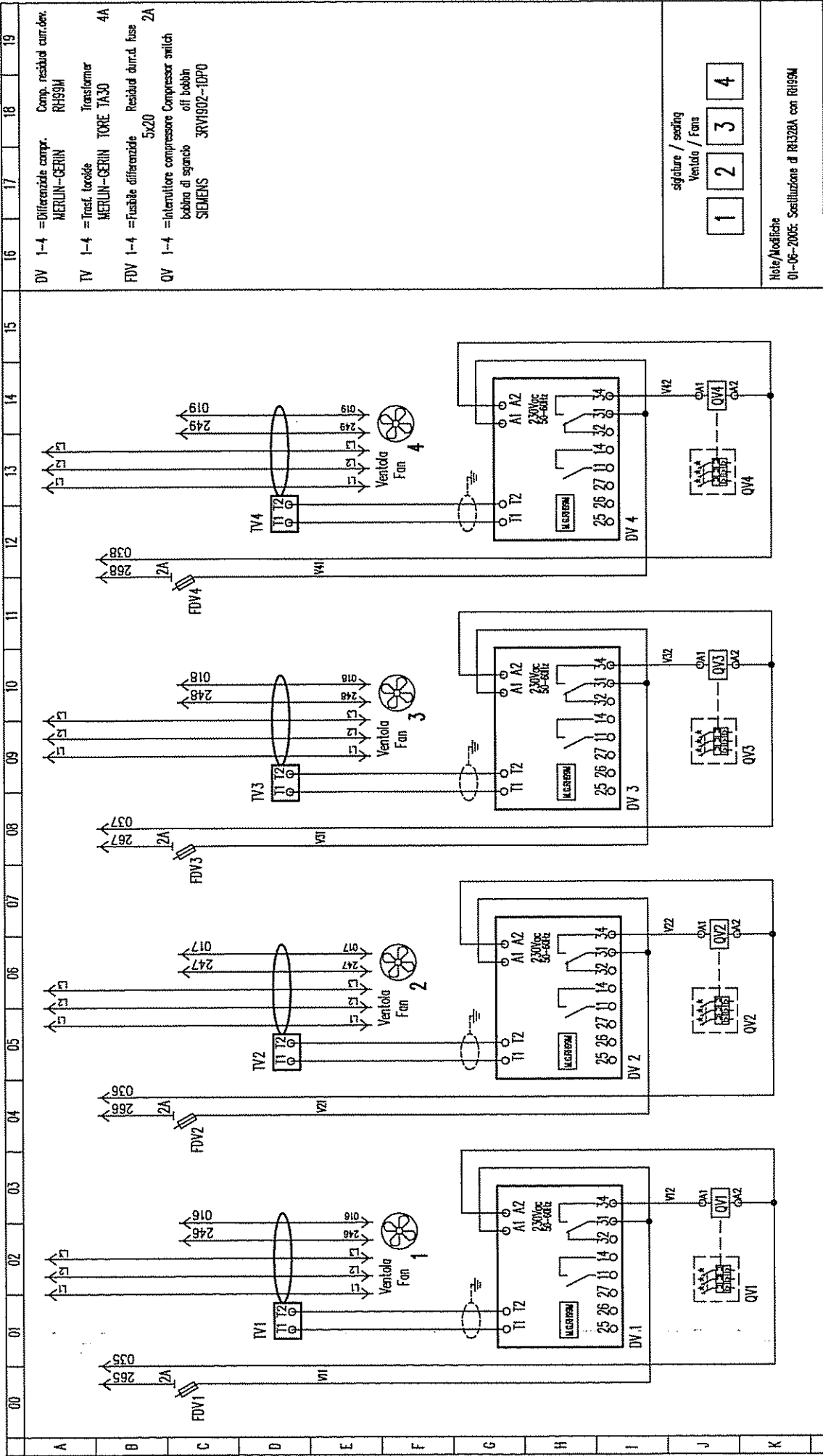

- DV 1-4 =Differenziale comp. Residual curr.der. MERLIN-GERIN RH99M
- TV 1-4 =Trasf. toroide MERLIN-GERIN TORE TA30 4A
- FDV 1-4 =Fusibile differenziale Residual curr.d. fase 5x20 2A
- QV 1-4 =Interruttore compressore Compressor switch bobina di spunto off bobbin SIEMENS 3RV1902-1DPO

signature / sealing
Ventola / Fans

1 2 3 4

Note/Modifiche
01-06-2005: Sostituzione di RH328A con RH99M

Tensione/Voltage/Spannung	380V-400V/3Ph/50-60Hz 220V-230V/3Ph/50-60Hz
N.O. /N.C.	rem. C3/C
Aux. voltage	230V/0c
Dim. /N.C.	DIF DIFFERENZIALE TECNOLOGIE DEL FREDDO
Scale	1 : X
Dev.	NET
Descr.	D COMPRESSOR RESIDUAL CURRENT DEVICE D VERDICHTER FERNSTROM RELAYS
Verifica	A. Taballo
Disegn.	UTQ 39130
Fog.	13

A. TABALLO IN L'ESCLUSIVA AUTORIZZAZIONE DELLA DISTRIBUZIONE TOTALE O PARZIALE DELLA PRESENTE DOCUMENTAZIONE.

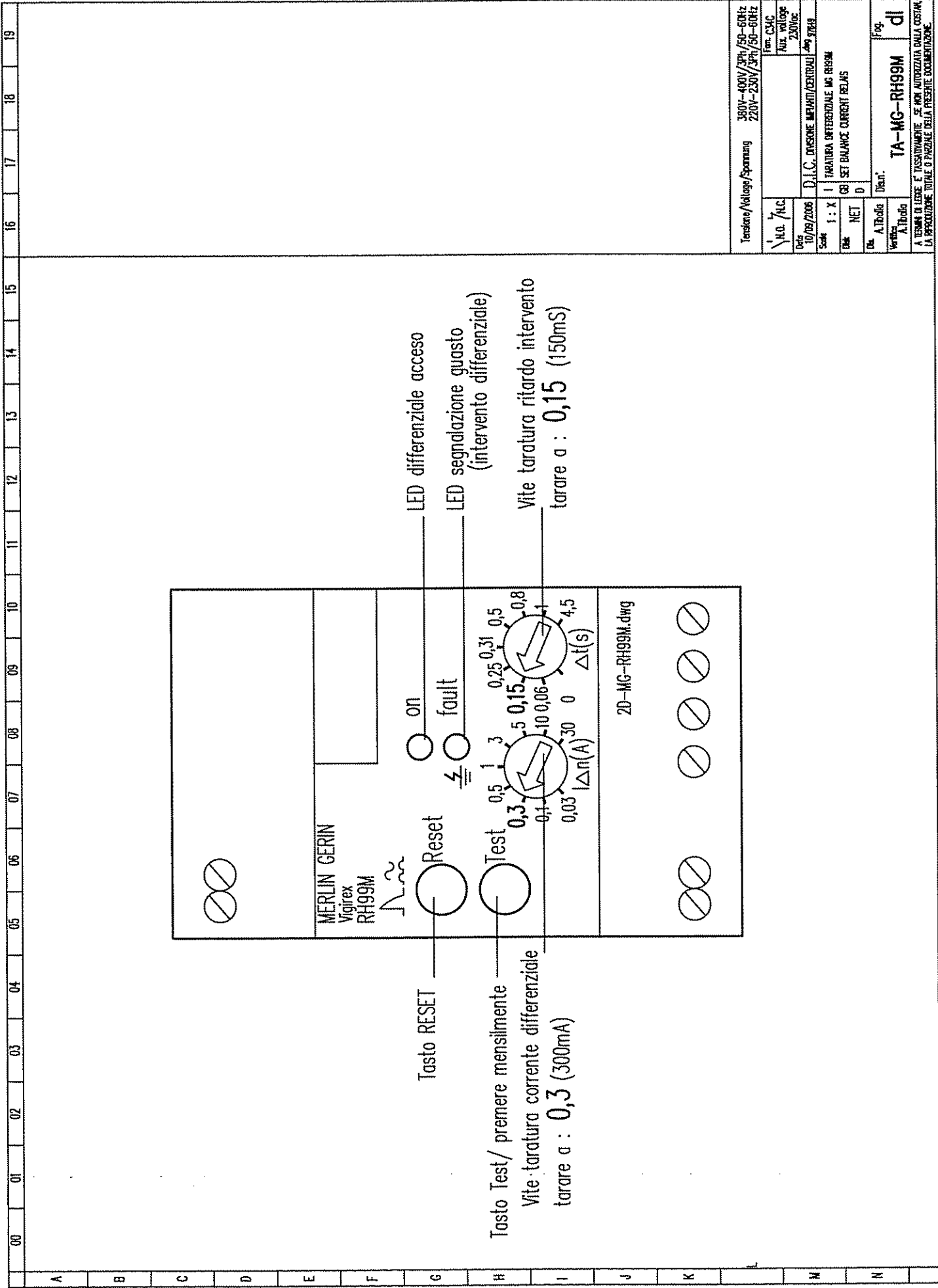

Tensione/Voltaggio/Spannung		380V-400V/3Ph/50-60Hz 220V-230V/3Ph/50-60Hz
Nome C.S.I.C.	Fime C.S.I.C.	
Aux. voltaggio	230V/0V	
D.I.C. DIVISIONE MEFANTI/CENTRALI - Imp. 9949		
Data	10/09/2006	1 TARATURA DIFFERENZIALE MG RH99M
Scala	1 : X	03 SET BALANCE CURRENT RELAYS
Dati	NET	D
Dis.	A. Tardito	
Verifica	A. Tardito	
Frog.		di
TA-MG-RH99M		

A DEBITO DI LEGGE E' TASSativamente SE NE AUTORIZZA SOLO IL COSTUIRE LA RIPRODUZIONE TOTALE O PARZIALE DELLA PRESENTE DOCUMENTAZIONE.

COSTAN TECHNICAL DOCUMENTATION	REVISION STATUS			TRUE COPY	PAGE 7 OF 1
PRODUCT: EPTAGLOO	ORD	DATE	CHANGE ORDER	OF THE SIGNED ORIGINAL	DATE OF 1st ISSUE
DOC. no. QSM0000406A CHAP. No.: 070	A	23.Feb.2010	RANGE EXTENSION		13/June/07
CHAPTER: CONTROL AND REGULATION	B				
	C				ISSUED BY MKT

070 – CONTROL AND REGULATION

Control and regulation electric panels

Function	Diagram n° / table	Sheet
DANFOSS EKC331T	UTQ39E10	E
Table of settings for EKC331T	TA-EKC331T-06-1.xls	E/2
CAREL IR32Z3	UTQ39E20	E
Table of settings for IR32Z3	TA-IR32Z3-2006.xls	E/2
DANFOSS AK-PC530 ¹	UTQ39E30	E
Auxiliary regulation relays	UTQ39E50	E/2
Table of settings for AK-PC530	TA-AK-PC530-1.3x3_6G-3-6V.xls	E/3
CAREL PCO3	UXQ39E2D0	E
Auxiliary regulation relays	UTQ39E50	E/2
Table of settings for PCO3	Ta-pco2-02_2005-ver1.5-WIKA.xls	E/3
CAREL uRack (micro Rack)	UTQ39E60	E
Table of settings for uRack	Ta-uRack-ver1.0.xls	E/2

¹ New name of controller EKC531 D1

COSTAN TECHNICAL DOCUMENTATION		REVISION STATUS		TRUE COPY OF THE SIGNED ORIGINAL	PAGE 7 OF 3	
PRODUCT: EPTAGLOO		ORD	DATE		CHANGE ORDER	DATE OF 1st ISSUE 13/June/07
DOC. no. QSM0000406A CHAP. No.: 080		A				ISSUED BY MKT
CHAPTER: OUTSTANDING RISKS AND EMERGENCY SITUATIONS		B				
		C				

080 - OUTSTANDING RISKS AND EMERGENCY SITUATIONS

All jobs carried out around the equipment must be done by authorized and competent personnel.

General risks

Component considered	Outstanding risk	Type	Caution
sheet metal with non-protected edges	Minor injuries	Contact	handle wearing protective gloves to avoid cuts consequent to mishandling
Compressors	Burns	Contact	Avoid accidental contact. Only handle with protective gloves.
Discharge pipes	Burns	Contact	Avoid accidental contact. Only handle with protective gloves.

Area considered	Outstanding risk	Type	Caution
Area around equipment	Injuries Intoxication Serious burns Death	Explosions due to increase in ambient temperature following fire.	Never leave compressor discharge and suction valves closed. Close only during maintenance and re-open before restarting the equipment
Area around equipment	Injuries Intoxication Serious burns Death	Fire due to short-circuit or overheating of power cable upstream of machine circuit breakers.	Connection cables and protection devices must be correctly sized following the instructions in Costan's technical literature
Danger area	Serious burns Electric shocks Death	Insulation fault of power cables located upstream of machine power cutoff switches.	Open the circuit breaker on the general electrical panel in the event of having to perform any jobs on the terminals upstream from the machine cutoff switch.
Danger area	Electric shocks Death	Live metal mass	Connect the earth wires of the equipment's electrical panel to the earthing system in the building so that all the metal parts of the unit are properly earthed.
Danger area	Serious burns Electric shocks Death	Contact with energized parts that have become accessible due to removal of covers.	Open the machine cutoff switch and lock this with the safety padlock provided before removing the covers and accessing internal equipment parts.
Danger area	Electric shocks Death	Maintenance of energized parts by authorized persons.	Never perform any jobs in the rain or when in contact with water and always work in the presence of another person.
Danger area	Electric shocks Death	Maintenance of energized parts by authorized persons.	Do not perform any job other than maintenance and setting on the controller-holding module. To this purpose use the appropriate key that only the authorized and qualified personnel is given.

COSTAN TECHNICAL DOCUMENTATION		REVISION STATUS		TRUE COPY	PAGE 8 OF 3
PRODUCT: EPTAGLOO		ORD	DATE	OF THE SIGNED ORIGINAL	DATE OF 1st ISSUE
DOC. no. QSM0000406A CHAP. No.: 080		A			13/June/07
CHAPTER: OUTSTANDING RISKS AND EMERGENCY SITUATIONS		B			ISSUED BY MKT
		C			

Refrigerant safety sheet

Substance identifying elements	
Details of components	<p>1, 1, 1 - trifluoroethane (R143a) CAS - No. 420 - 46 - 2 EEC - No. 206 - 996 - 5</p> <p>Pentafluoroethane (R125) CAS - No. 354 - 33 - 6 EEC - No. 206 - 557 - 8</p> <p>1, 1, 1, 2 - tetrafluoroethane (R134a) CAS - No. 811 - 97 - 2 EEC - No. 213 - 377 - 0</p>
Identification of hazards	<p>Specific hazards: rapid evaporation of the liquid can cause frost-bite.</p> <p>Greater hazards: the vapors are heavier than air and can cause suffocation by reducing the oxygen available for breathing.</p>
First-aid measures	<p>General information: do not administer anything to persons who have fainted</p> <p>Inhalation: take the person involved into the fresh air. Give oxygen or artificial respiration if necessary. Do not administer adrenaline or similar substances.</p> <p>Contact with eyes: Carefully rinse with plenty of water for at least 15 minutes and see a doctor.</p> <p>Contact with skin: Wash immediately with plenty of water. Immediately take off contaminated clothing.</p>
Fire-prevention measures	<p>Appropriate fire-fighting equipment: any</p> <p>Specific hazards: Pressure rise</p> <p>Specific fire-fighting methods: cool containers/tanks with water jets.</p>
Measures to be taken in case of accidental leaks	<p>Individual precautions: evacuate personnel to safety areas.</p> <p>Environmental precautions: none because the fluid evaporates.</p> <p>Cleaning methods: not necessary because fluid evaporates.</p>
Handling and storing	<p>Handling</p> <p>-Technical measures/precautions: make sure sufficient air is circulating in the work premises and/or that air extraction is adequate</p> <p>-Hints for safe use: Use only in well-ventilated premises. Do not breathe vapors or aerosols.</p> <p>Storage</p> <p>-Technical measures/storage methods: carefully close and keep in a cool, dry and well-ventilated environment.</p> <p>-Incompatible products: explosives, flammable materials, organic peroxides</p> <p>-Packaging materials: keep in original containers</p>
Exposure control / individual protection:	<p>Control parameters – exposure limit values:</p> <p>1, 1, 1 - trifluoroethane (R143a) AEL (8-H E 12-H TWA) = 1000 ml/m³ Dupont (1992)</p> <p>Pentafluoroethane (R125) AEL (8-H E 12-H TWA) = 1000 ml/m³ Dupont (1992)</p> <p>1, 1, 1, 2 - tetrafluoroethane (R134a) AEL (8-H E 12-H TWA) = 1000 ml/m³ Dupont (1992)</p> <p>Individual protection:</p> <p>- breathing protection: during salvage and cfc tank operations, independent breathing apparatus must be used. The vapors are in fact heavier than air and can cause suffocation by reducing the oxygen available for breathing.</p> <p>- eye protection: Safety goggles</p> <p>- hand protection: rubber gloves.</p> <p>Specific hygienic precautions: do not smoke.</p>
Chemical-physical properties	<p>Physical state (20°C): Liquefied gas</p> <p>Color: colorless</p> <p>Smell: similar to ether</p> <p>pH: neutral</p> <p>Boiling point/interval: -46.7 °C</p> <p>Flash point: Non flammable</p> <p>Explosive properties: no available details</p> <p>Vapor pressure: 1234 kPa (25°C) 2310 kPa (50°C)</p> <p>Relative density: 1050 kg / cu.m (at 20°C – liquid)</p> <p>Solubility in water: negligible</p>
Stability and reactivity	<p>Stability: no decomposition if used according to instructions.</p> <p>Conditions to be avoided: contact with alkaline metals, earthy alkaline metals, granulated metal salts, Aluminum, Zinc, Beryllium, etc. in powder.</p> <p>Hazardous decomposition products: halogen acids, traces of carbonyl halides.</p>
Toxicological details	<p>1, 1, 1 - trifluoroethane (R143a) LC50/inhalation/4 hours/on rats => 540 ml / l</p> <p>pentafluoroethane (R125) LC50/inhalation/1 hour/on rats => 3480 mg / l</p> <p>1, 1, 1, 2 - tetrafluoroethane (R134a) ALC/inhalation/4 hours/on rats => 567 ml/l</p>

COSTAN TECHNICAL DOCUMENTATION	REVISION STATUS		TRUE COPY	PAGE 9 OF 3
PRODUCT: EPTAGLOO	ORD	DATE	CHANGE ORDER	OF THE SIGNED ORIGINAL
DOC. no. QSM0000406A CHAP. No.: 080	A			DATE OF 1st ISSUE
CHAPTER: OUTSTANDING RISKS AND EMERGENCY SITUATIONS	B			13/June/07
	C			ISSUED BY MKT

Substance identifying elements	Local effects: concentrations well above the TLV value can cause narcotic effects. Inhalation of high concentrations of products in decomposition can cause breathing difficulty (pulmonary edema). Long-term toxicity: during experiments carried out on animals no carcinogenic, teratogenic or mutagenic effects were found. Specific effects: rapid evaporation of the liquid can cause frost-bite.
Ecological information	Effects tied to eco-toxicity: Pentafluorethane (R125) halocarbons global warming potential; HGWP; (R-11 = 1) =0.84 Potential global warming effect of halocarbons;; ODP; (R-11 = 1) = 0 Trifluorethane (R143a) halocarbons global warming potential; HGWP; (R-11 = 1) =1.1 Potential global warming effect of halocarbons;; ODP; (R-11 = 1) = 0 Tetrafluorethane (R134a) halocarbons global warming potential; HGWP; (R-11 = 1) =0.28 Potential global warming effect of halocarbons;; ODP; (R-11 = 1) = 0
Disposal	Waste refuse/unused products: utilizzabile con ricondizionamento contenitori contaminati : i recipienti depressurizzati dovrebbero essere restituiti al fornitore
Information regarding regulations	EEC Directive Safety sheet: D91/155/EEC amended by D 93/112/EEC "hazardous substances and compounds" "Hazardous compounds: D 67/548/EEC amended by D 93/21/EEC "labeling guide" Circulars 46/79 and 61/81 issued by the Ministry of Labor "Risks relating to the use of products containing aromatic amines" D.L. n. 133/92 "Regulations relating to the disposal of hazardous substances in groundwaters" D.L. n. 277/91 "Protection of workers from noise, lead and asbestos" M.D. 28/01/92 "Classification and rules governing packaging and labeling of hazardous Compounds" P.D. n. 175/88 "Activities entailing serious accident risks (Seveso Law)" P.D. n. 203/88 "Emissions into the atmosphere" P.D. n. 303/56 "Work hygiene" P.D. n. 547/55 "Regulations governing accident prevention" Law 319/76 "Protection of waters (also known as Merli law)"

These indications conform to those provided by the supplier and are to be considered as based on the latest knowledge relating to the substance in question. Products must be used for the specific purposes for which they were intended in accordance with the indications shown above. All other uses must be carefully assessed in terms of the risks involved. The list of rules and regulations is provided as a mere indication and should not be considered complete. The user shall be responsible for making reference to the official regulations of the country of installation, as regards the use, storage and handling of products.

COSTAN TECHNICAL DOCUMENTATION		REVISION STATUS			TRUE COPY	PAGE 7 OF 5
PRODUCT: EPTAGLOO		ORD	DATE	CHANGE ORDER	OF THE SIGNED ORIGINAL	DATE OF 1st ISSUE
DOC. no. QSM0000406A CHAP. No.: 090		A	28.July.20090	OIL SAFETY SHEET		13/June/07
CHAPTER: MAINTENANCE		B	23.Feb.2010	RANGE EXTENSION		
		C	11.Nov.2010	SAFETY VALVE ADDED		ISSUED BY MKT

090 - MAINTENANCE

Constant supervision of machine conditions and correct maintenance guarantee reliability and efficient operation of the entire system over time. This chapter caters for qualified personnel and addresses scheduled controls and maintenance but also deals with a series of checks that the user himself can do at the indicated intervals. For example, some simple visual controls of the system's main components that require no particular technical skills

Periodic machine maintenance

- Control of machine structural integrity: the metal panels composing the casing must be firmly secured to the structure; removable panels and peep panels must not cause irregular vibration or noise during operation.
- Control oxidized parts: Rust must be removed; ascertain rust causes, remedy and if necessary repair.
- Control of leaks: unusual oil spots on the floor, condensation due to damaged insulation and leaking piping demand immediate assistance from Epta after-sales service.
- check the integrity of the electric power line: the power cord connecting the machine to the power source must be in perfect condition, with no cracks or damage that may jeopardize insulation. Should repairs be needed, request assistance from the after-sales service.
- Check the tripping capacity of safety pressure-switches as per the laws in force
- Check the tripping capacity of the pressure-switches protecting the compressor¹

Machine maintenance

The actions indicated here below are restricted to the authorized personnel and must be performed following the recommended frequency after start up.

Disconnect the machine from the power feed before attempting any maintenance. Avoid contact with the hot internal parts.

CONTROL/ACTION	WEEKLY	MONTHLY	2-YEARLY
Measure discharge pressure	X		
Measure suction-line pressure	X		
Measure electric power voltage	X		
Measure current intensity (Amperage)	X		
Check that electrical contacts and connections are tight		X	
Check compressor oil level		X	
Check moisture and liquid viewer		X	
Check suction filters			X
Check whether motor-driven fans are securely fastened ²			X

¹ Pressure switches are calibrated before test run as per operational instruction QOP019110A

² This only refers to versions fitted with an enclosure.

COSTAN TECHNICAL DOCUMENTATION		REVISION STATUS		TRUE COPY OF THE SIGNED ORIGINAL	PAGE 8 OF 5	
PRODUCT: EPTAGLOO		ORD	DATE		CHANGE ORDER	DATE OF 1st ISSUE
DOC. no. QSM0000406A CHAP. No.: 090		A	28.July.20090		OIL SAFETY SHEET	13/June/07
CHAPTER: MAINTENANCE		B	23.Feb.2010		RANGE EXTENSION	ISSUED BY MKT
		C	11.Nov.2010	SAFETY VALVE ADDED		

Control of the **liquid sight glass** may indicate that the filter dryer core needs replacing. The color of the sensitive element may vary from green to yellow according to the amount of humidity in the circuit. Deep yellow or yellow-rose indicates that the core is unable to hold any more humidity and must be replaced.

A strong flow resistance along the suction filters denotes that the mesh microfilter core is clogged with residue and dirt. Cores must then be replaced.

Safety valve (Pressure relief valve)

It is advisable to replace the safety valve after it has tripped; valve discharging may cause manufacturing residues that proceed from components and pipes to build up against the valve seal, which may impair valve tightness after opening.

	<p>Safety valves must be replaced regularly as required in the instructions from the valve's manufacturer. They must be test-operated as established by law (e.g. Italian DM 1/12/2004 n° 329, attachment B).</p> <p>for systems in category III and V : every 3 years.</p> <p>for systems in category I and II: every 4 years.</p>
---	--

Prior to replacing the valve, make sure that the system area in which the jobs are carried out is free from pressure and high temperature. When installing, strictly follow the instructions on the package.

Systems including an on-board liquid receiver have a valve with a lead seal between the liquid receiver and the safety (pressure relief) valve. This valve is open because this is how it guarantees correct functioning of the safety device. When the pressure-relief valve is replaced the lead seal must be broken in order for the lead-sealed valve to be closed. As soon as the new safety valve is in place it will be necessary to open the previously lead-sealed valve back again, so restoring normal operation conditions.

	<p>When these steps are accomplished it will be necessary to apply a new lead seal to the valve to protect it from being accidentally closed and from consequently shutting the pressure-relief valve off.</p>
---	---

Compatibility of lubricants for motor-driven Bitzer compressors using R404A

Bitzer compressors appropriate for use with HFC refrigerants and polyester oil charge, are singled out by letter "Y" in the model acronym (e.g. 4CC-6.2Y). The lubricant oil the Bitzer compressors in Eptagloo systems are charged with at the time of delivery is BSE32, which is recommended for a maximum condensation temperature of 55°C.

Before any jobs, it is advisable to check the original oil type on the compressor rating plate. When in doubt, contact Epta's service center.

Find below a chart listing the Bitzer-approved lube oils by other manufacturers, which have properties similar to the BSE 32 lube oil of initial charge.

COSTAN TECHNICAL DOCUMENTATION		REVISION STATUS			TRUE COPY	PAGE 9 OF 5
PRODUCT: EPTAGLOO		ORD	DATE	CHANGE ORDER	OF THE SIGNED ORIGINAL	DATE OF 1st ISSUE
DOC. no. QSM0000406A CHAP. No.: 090		A	28.July.20090	OIL SAFETY SHEET		13/June/07
CHAPTER: MAINTENANCE		B	23.Feb.2010	RANGE EXTENSION		
		C	11.Nov.2010	SAFETY VALVE ADDED		ISSUED BY MKT

Compressor type	(HFC) Refrigerant	Oil type	Viscosity at 40°C	Supplier - oil type
Bitzer 2CC-..Y – 4NCS- ..Y	R404A R134a R407A R407B R407C R507A	Bitzer BSE 32 (polyester)	32 cst	Castrol Icematic SW 32 CPI Solest 31-HE Exxon Mobil EAL Arctic 22CC Exxon Mobil EAL Arctic 32 Fuchs SEZ 32 Shell Clavus R32 Uniquema RL 32 H

Data provided by Bitzer (technical instruction KT-510-3)

COSTAN TECHNICAL DOCUMENTATION		REVISION STATUS			TRUE COPY	PAGE 10 OF 5
PRODUCT: EPTAGLOO		ORD	DATE	CHANGE ORDER	OF THE SIGNED ORIGINAL	DATE OF 1st ISSUE
DOC. no. QSM0000406A CHAP. No.: 090		A	28.July.20090	OIL SAFETY SHEET		13/June/07
CHAPTER: MAINTENANCE		B	23.Feb.2010	RANGE EXTENSION		
		C	11.Nov.2010	SAFETY VALVE ADDED		ISSUED BY MKT

Compatibility of lubricants for Frascold motor-driven compressors using R404a

The Frascold compressors appropriate for use with HFC refrigerants and polyester oil charge, are marked out by letter "Y" in the model acronym (e.g. Q 5 33.1Y). The lubricant oil that the Frascold compressors in the systems of the Eptagloo family are charged with when delivered is FRASCOLD FC series 32; this is recommended for a maximum condensation temperature of 55°C.

Before any jobs, it is advisable to check the original oil type on the compressor rating plate. When in doubt, contact Epta's service center.

Below a chart is given that lists the Frascold-approved lube oils by other manufacturers, as having properties similar to the FRASCOLD FC series 32 lube oil that the system is charged with when delivered.

Compressor type	(HFC) Refrigerant	Oil type	Viscosity at 40°C	Supplier - oil type
Fracold C 2 12 Y - S 15 56 Y	R404A R134a R407A R407B R407C R507A	FRASCOLD FC series 32 (polyester)	32 cst	Castrol Icematic SW 32 CPI Solest 31-HE Exxon Mobil EAL Arctic 22CC Exxon Mobil EAL Arctic 32 Fuchs SEZ 32 Shell Clavus R32 Uniquema RL 32 H

	When performing jobs that involve handling lubricants, waste oil disposal or the measures to be taken in case of accidental leak or spillage, strictly abide by the instructions in the Safety sheet, section 090 "OUTSTANDING RISKS AND EMERGENCY SITUATIONS" of this manual.
---	---

COSTAN TECHNICAL DOCUMENTATION	REVISION STATUS			TRUE COPY	PAGE 11 OF 5
PRODUCT: EPTAGLOO	ORD	DATE	CHANGE ORDER	OF THE SIGNED ORIGINAL	DATE OF 1st ISSUE
DOC. no. QSM0000406A	A	28.July.20090	OIL SAFETY SHEET		13/June/07
CHAP. No.: 090	B	23.Feb.2010	RANGE EXTENSION		
CHAPTER: MAINTENANCE	C	11.Nov.2010	SAFETY VALVE ADDED		ISSUED BY MKT

Control of operating condition and overall condition (as per Italian law DM 329/04)

Such inspection and testing must be performed by qualified personnel (ISPELS or notified bodies) and specific requests must be addressed to them.
Inspection intervals depend on the PED category quoted in the conformity declaration for the refrigerating plant as indicated in attachment B to M.D: 329/04.

DM 329/04 Attachment B	
TABLE – Reconditioning intervals for pressure equipment (section 10, subsections 3 and 5)	
PRESSURE EQUIPMENT	INSPECTION LIMITS AND INTERVALS
EQUIPMENT/SETS OF APPLIANCES CONTAINING FLUIDS GROUP 2 (D.Lgs. 93/2000 art.3)	
Vessels/sets of devices containing compressed, liquefied, dissolved or vapor gas other than water vapor under categories III and IV, and vessels containing water vapor or superheated water belonging in categories from I to IV	Inspection intervals: - every 3 years; Test-operation - every 10 years; Control of overall condition
Vessels/sets of devices containing compressed, liquefied, dissolved or vapor gas other than water vapor under categories I and II	Inspection intervals: - every 4 years; Test-operation - every 10 years; Control of overall condition

Equipment decommissioning and disposal

At the end of its life cycle, or in case the equipment or parts thereof are decommissioned, the equipment must be disposed of in compliance with the laws in force at the time of decommissioning.

- In particular, the system must be emptied and the refrigerating fluid must be recovered using the appropriate equipment. The refrigerant can later be re-used or stored and disposed of by an authorized company.
- Compressors contain oil that will have to be duly recovered and disposed of by an authorized company.
- Do not release the refrigerating fluid, the oil and the other materials in the environment.
- Do not use open flames or disassemble parts of the system before having recovered the refrigerating fluid; such recovery must only be performed by specialized personnel.