

PRESENTATION

COSMOS ECO REVERSE

COSMOS ECO REVERSE



Boost our food offer flexibility and simplify store seasonality management

COSMOS ECO REVERSE

Reverse technology

Epta Reverse technology is a new approach of chest freezer use in frozen food area. Only dedicated to CO2 transcritical system, this new product feature has been designed in a very simple and reliable way that make it easy to be implemented in all stores.

Epta Reverse technology allows Cosmos ECO chest freezer to be switched from low temperature application to medium temperature one in an user friendly way. This operation just requires to turn a key lock located next to the controller. **No assistance from frigorist** needed.

Compared to a single temperature chest, **Epta Reverse technology only needs an additional suction pipe** coming from machinery room. **Extra installation cost are limited. All pipings**, 3 way or non return valves and by pass are already **factory mounted** in COSMOS ECO REVERSE chest freezer.

Powered by Danfoss™ dedicated device and controller, this **breakthrough innovation** will help you to **boost your food offer** flexibly, **adapt your segmentation** to shopper need, **improve cross merchandising** effect on sales and **simplify store seasonality management**.

User friendly Key switch device



Factory mounted 3 lines piping



4 display solutions

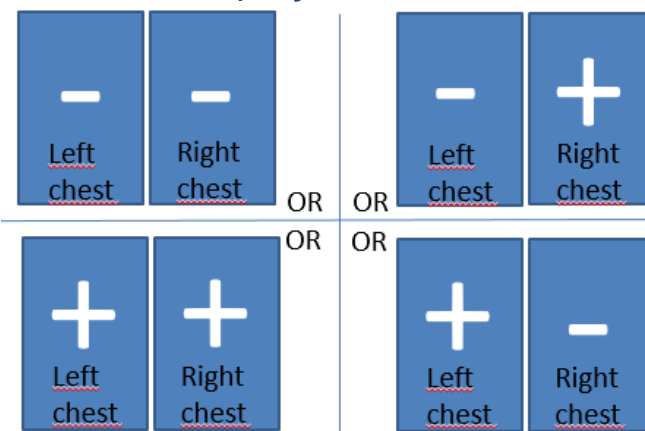

COSMOS ECO REVERSE

Main advantages

Cosmos ECO REVERSE main advantages are :

- Seasonality management linked our innovative Epta Reverse temperature switch device
- Double independent evaporators , one on each chest side, able to manage two application temperatures in the same island
- Increased storage volume thanks to its upper elevated loading line from 400 to 450 mm
- Enhanced resistance to condensation due to new aeraulic design and smart additional devices
- New appealing bumper design under the glass that reinforce perceived quality of robustness

For internal use only

COSMOS ECO REVERSE

Product at a glance

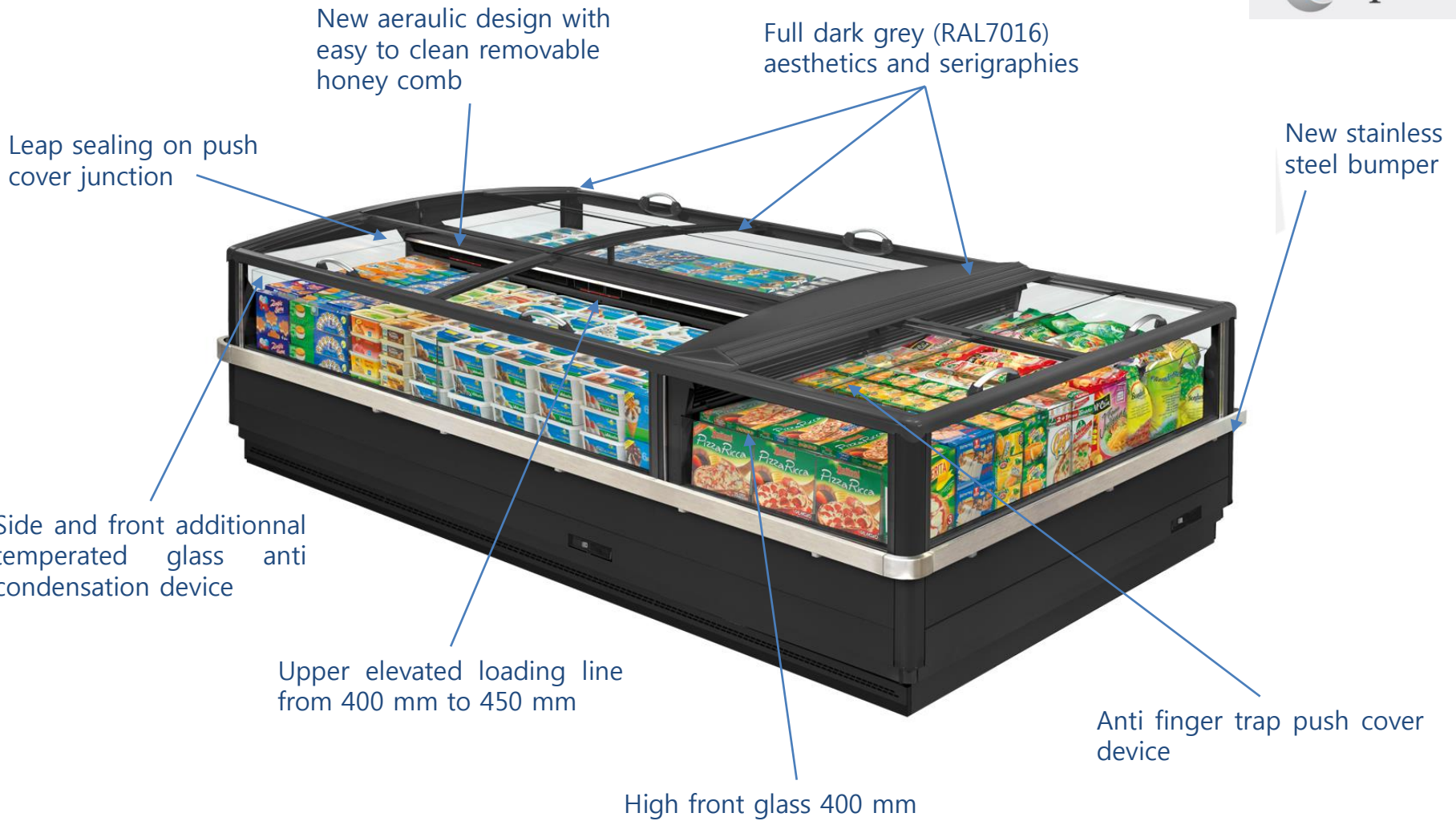

COSMOS ECO REVERSE

Product at a glance

COSMOS ECO REVERSE product range

Width : 2000 mm only

Lengths : 250 and 375 linears, 200 EOL

Temperature class : 3L1, 3M2*, 3M1*

Lighting position : without, center or handrail or both

LED offer : value or advance

Fluids : CO₂ transcritical

Controllers : Danfoss AK-CC 550A

Controllers position : one on each chest side

Defrost : electrical

Electronics : SRTS

Covers : push

End wall : panoramic

Aesthetic and cover color : Dark grey (RAL 7016)

Food display : wired grid, elevated bottom

Ticket holder position : Pyramid

Ticket holder type : Universal rail, Paper 40 or 52mm)

Chest dividers : glass, wired (125, 160, 195, 275, 370)



188 version is not available

CO₂ transcritical only

Danfoss AKCC 550 controller only

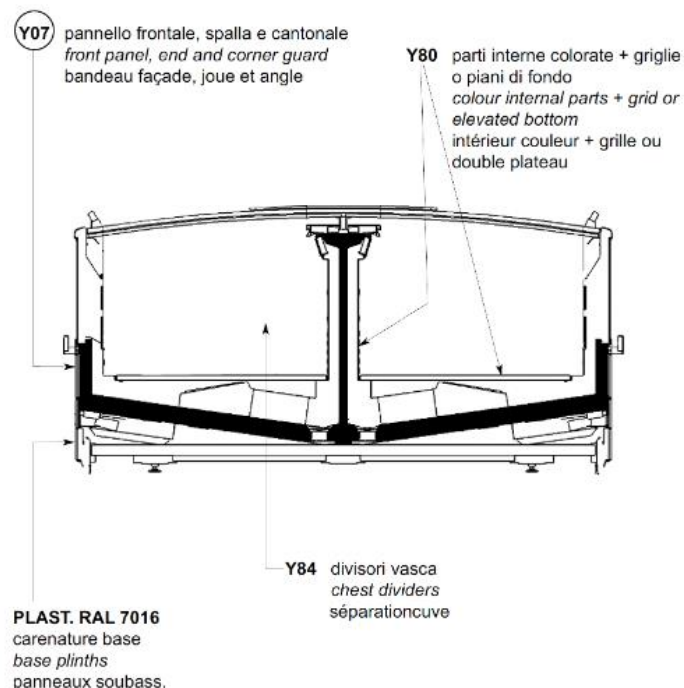

COSMOS ECO REVERSE

Dimensions – Linear

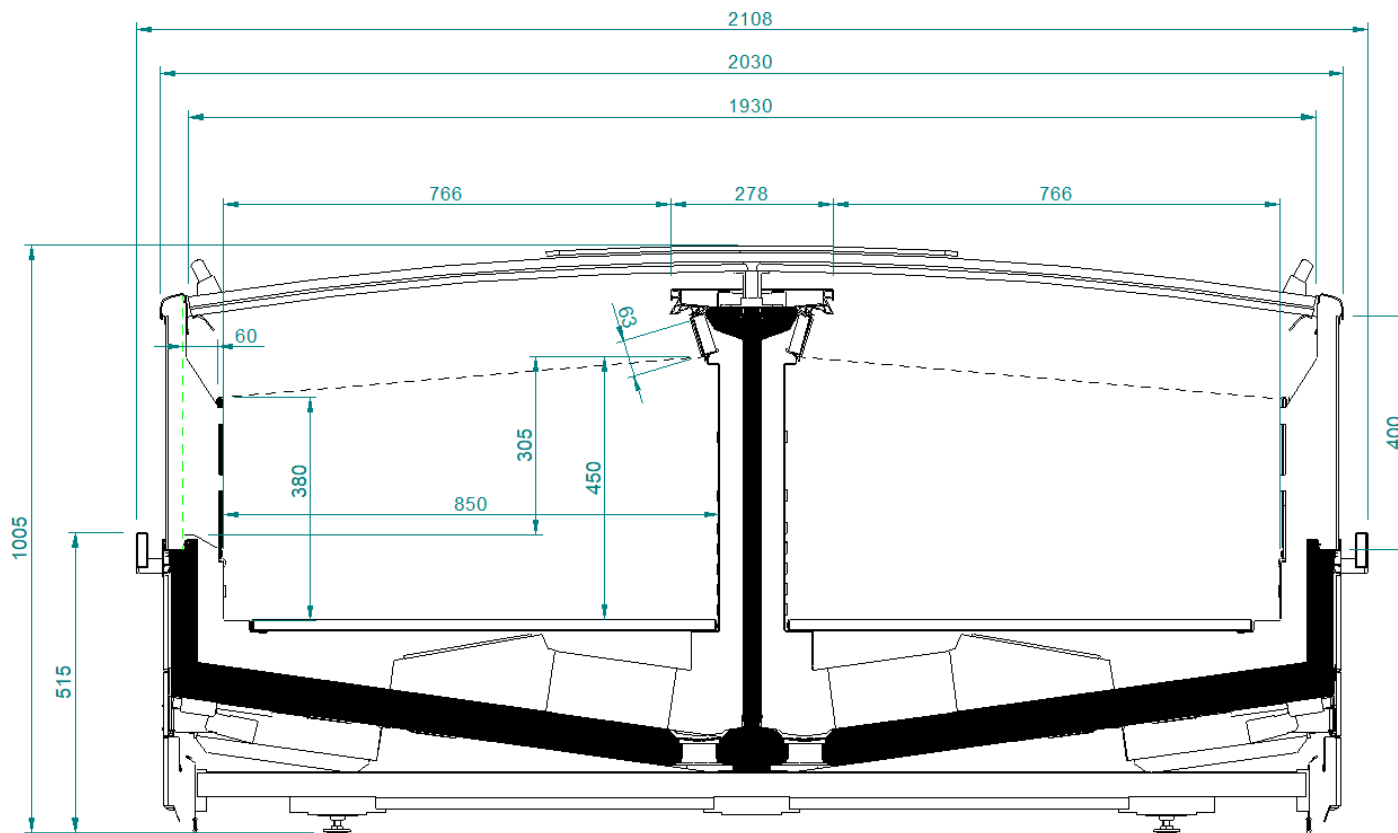



Models	L (mm)	L (mm)	V (dm ³)	TDA (m ²)
250	2500	2634	1750	5,1
375	3750	3884	2630	7,7

COSMOS ECO REVERSE

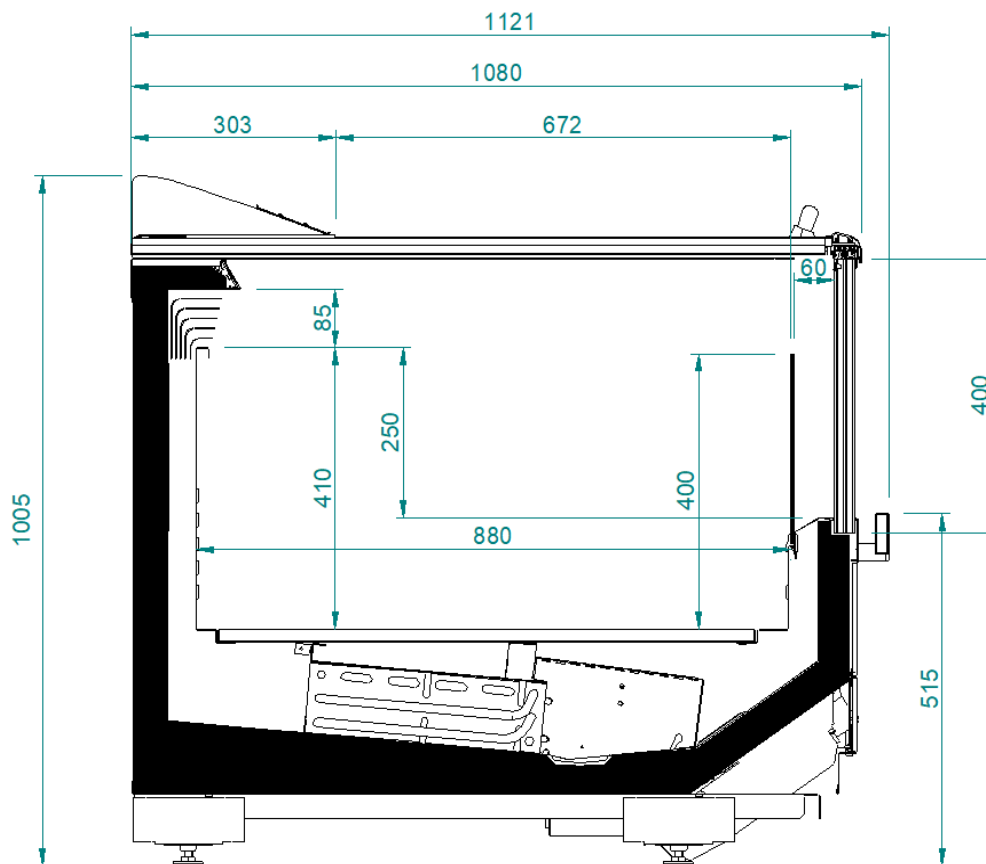
Dimensions – EOL

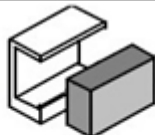

Models	L (mm) 	V (dm ³) 	TDA (m ²) 
EOL	2016	679	1,7



www.bonnetneve.com



Bonnet Névé S.A. participates in the ECC programme for Refrigerated display cabinets (RDC). Check ongoing validity of certificate online: www.eurovent-certification.com or using: www.certiflash.com



www.eptarefrigeration.com