



Epta S.p.A. participates in the ECC programme for Refrigerated display cabinets (RDC). Check ongoing validity of certificate online: [www.eurovent-certification.com](http://www.eurovent-certification.com) or using: [www.certiflash.com](http://www.certiflash.com)



# Shape E Design

Shape E Design									
Lunghezza mm	937	1250	1875	2500	3125	3750	AF 45°	AO 90°	AO 45°
Shape E Design	DD	•	•	•	•	•	•		
	LD	•	•	•	•			•	•
	ODF	•	•	•	•		•		•
	DDP	•	•	•	•		•	•	•
	DC	•	•	•	•	•	•	•	•
	LS	•	•	•	•	•	•	•	•
Superficie di Esposizione m2	0.75								
Superficie di appoggio m2	1.01								
Spessore spalla mm	35.00								

# Shape E Design

LD

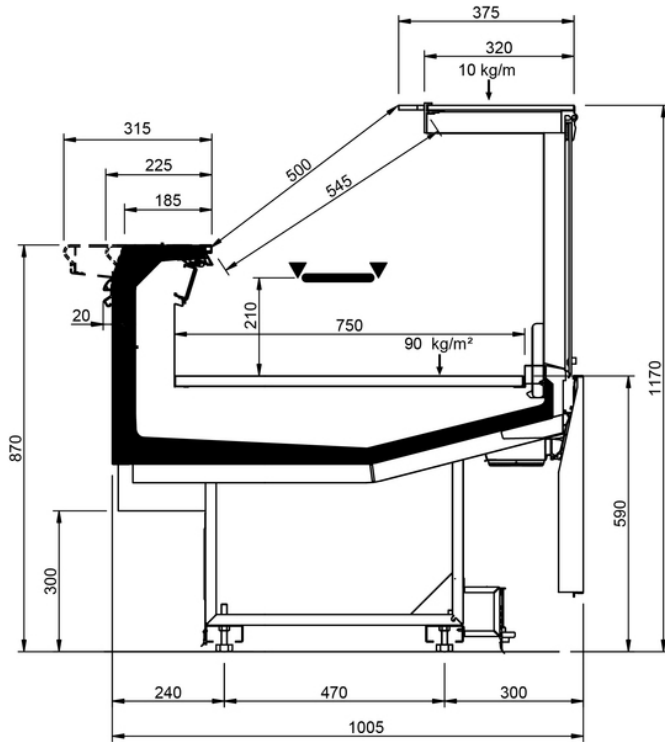

DD

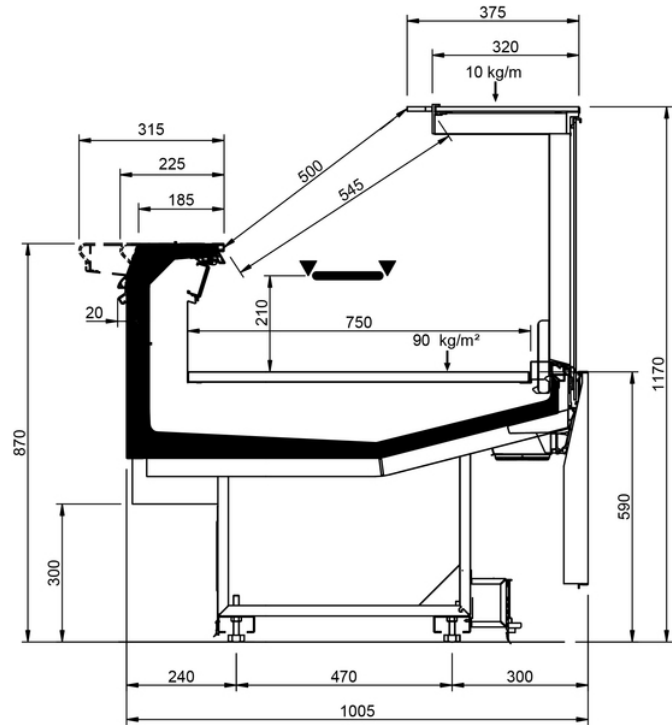

DDP

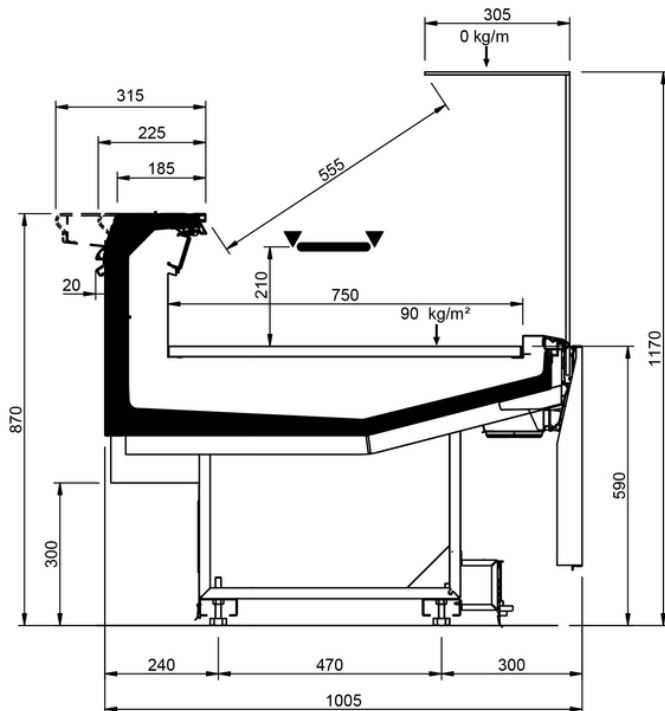

ODF

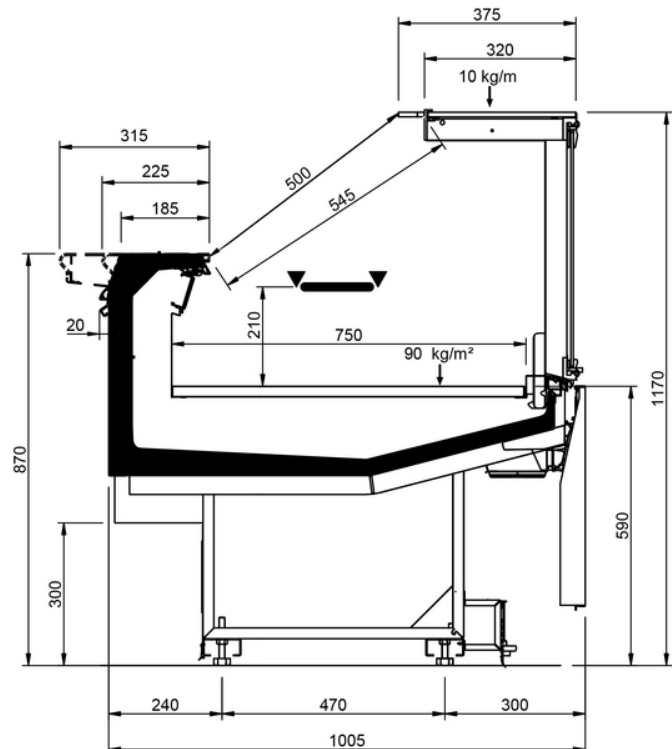

DC

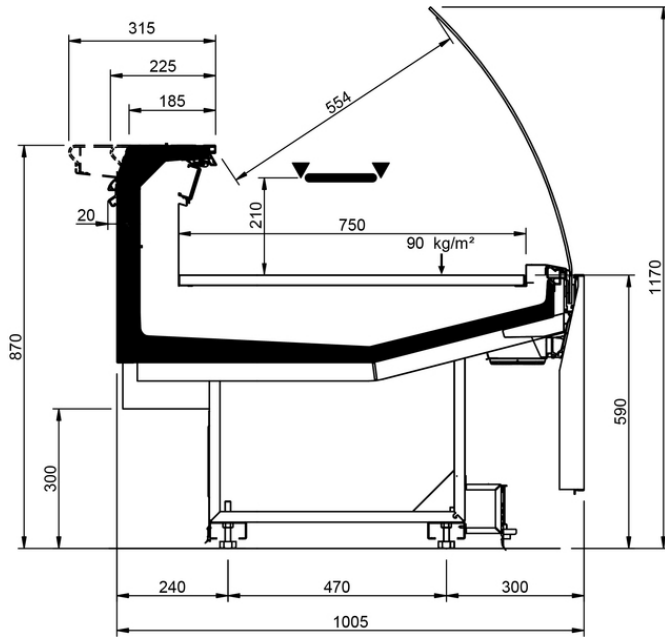

LS-D

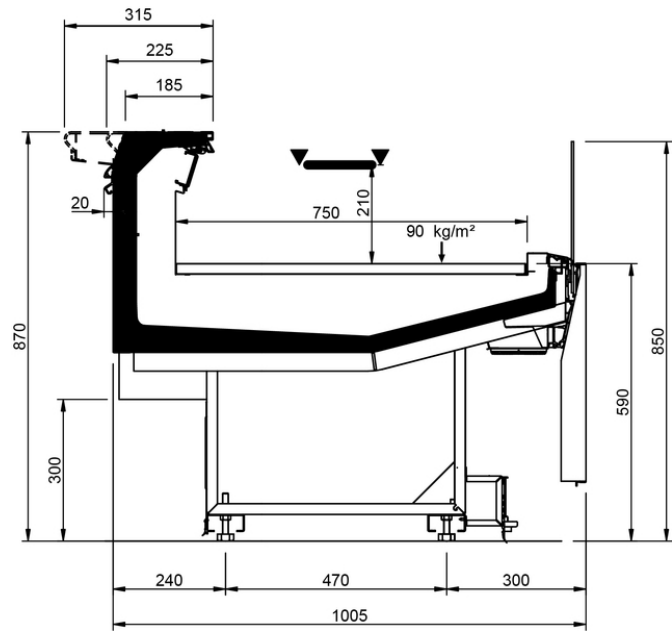

LS-P

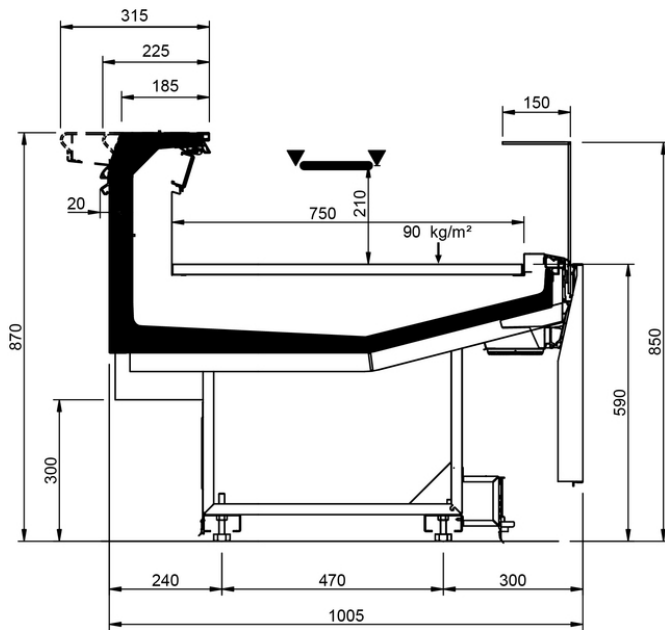

LS-C

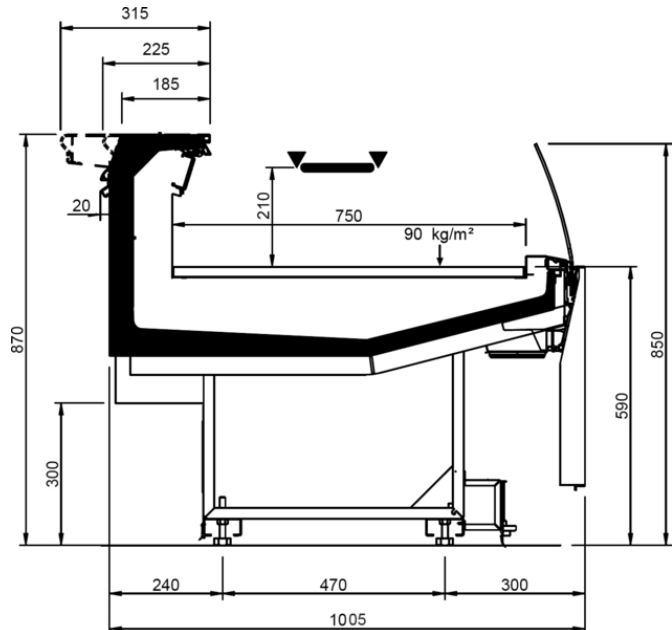



## Legenda

 Carne	 Polli	 Pesce	 Pesce confezionato
 Salumi	 Formaggio	 Latticini	 Gastronomia
 Pasticceria	 IV Gamma	 Frutta e Verdura	 Sandwiches
 Bevande	 Pizza	 Pane	 Surgelati e gelati
 Sbrinamento a fermata semplice	 Sbrinamento elettrico	 Sbrinamento a gas caldo	 Sbrinamento manuale
 Ventilato	 Statico	 Gruppo incorporato	 Gruppo remoto
 Bagnomaria	 Piano in vetroceramica	 Ghiaccio	 VSD Tecnologia con Inverter
 Illuminazione Led	 Porte Zero C	 Ventilatori ad alta efficienza	 R290 Gas refrigerante R290/Propano
 R134a R-134a - 400V/3PH/50Hz	 R404A R404A - 400V/3PH/50HZ	 R744 R744 - 400V/PH/50Hz	 Compressore semiermetico alternativo
 Compressore ermetico scroll	 Compressore ermetico alternativo	 Installazione all'esterno	 Installazione all'interno
 Insonorizzazione	 Condensatore a bordo	 Condensatore remoto	 DUAL Media e bassa temperatura