

# DUALIO E SV

Mozaik

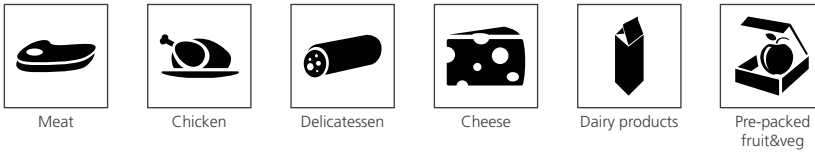

## Product categories



## Technical features



## Product range

DUALIO E SV						
<b>Lenght</b> -Lunghezza Longueur-Länge-Longitud mm		<b>1250</b>	<b>1875</b>	<b>2500</b>	<b>3750</b>	<b>EOL 1650</b>
<b>1 SHELF</b>		•	•	•	•	•
<b>2 SHELVES</b>		•	•	•	•	•
<b>Display area</b> Superficie di esposizione Warenpräsentationsfläche Surface d'exposition Superficie expositiva m <sup>2</sup>	<b>1 S</b>	2.53	3.82	5.06	7.59	1.80
	<b>2 S</b>	2.53	3.82	5.06	7.59	1.80
<b>Loading area</b> Superficie di appoggio Nutzfläche Surface de chargement Superficie de apoyo m <sup>2</sup>		2.06	3.09	4.12	6.18	1.6
<b>End thickness</b> Spessore spalla Stärke der Seitenwand Épaisseur de cheve joue Espesor lateral mm		50.00				

## Cross sections

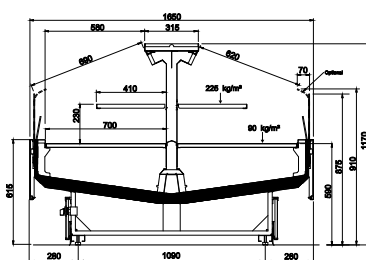

1 SHELVES

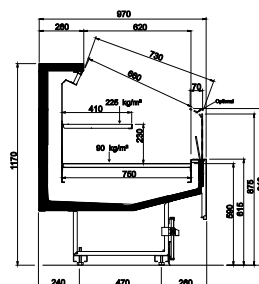

EOL - 1 SHELVES

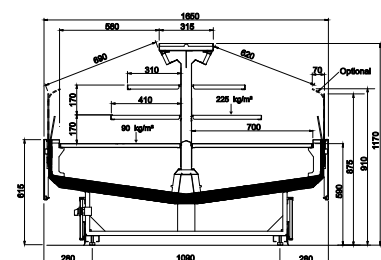

2 SHELVES

## Cross Sections

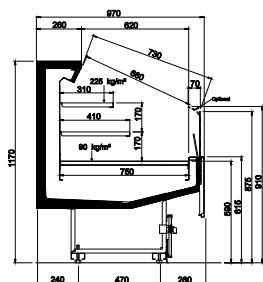

EOL - 2 SHELVES