



## Product categories



Meat



Chicken



Delicatessen

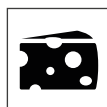

Cheese

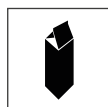

Dairy products



Gastronomy



Pastries

## Technical features



Ventilated

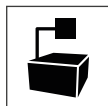

Remote  
condensing unit



LED lighting



High efficiency  
fans



Off-cycle  
defrost

## Certification and patents



Eurovent\*



TechnoKleen



Epta Adamant

\* Epta S.p.A. participates in the ECC programme for:  
Refrigerated display cabinets (RDC); Check ongoing validity  
of certificate online: [www.eurovent-certification.com](http://www.eurovent-certification.com)  
or using: [www.certiflash.com](http://www.certiflash.com)

## Product range

SHAPE E STUDIO									
Length-Lunghezza Longueur-Länge-Longitud mm	937	1250	1875	2500	3125	3750	AO 90°	AO 45°	AF 45°
<b>DD</b>	•	•	•	•	•	•			
<b>LD</b>	•	•	•	•		•	•	•	
<b>ODF</b>	•	•	•	•		•		•	•
<b>DDP</b>	•	•	•	•	•	•	•	•	•
<b>DC</b>	•	•	•	•	•	•	•	•	•
<b>LS</b>	•	•	•	•	•	•	•	•	•
<b>Display area</b> Superficie di esposizione Warenpräsentationsfläche Surface d'exposition Superficie expositiva m2/ml	0.75								
<b>Loading area</b> Superficie di appoggio Nutzfläche Surface de chargement Superficie de apoyo m2/ml	1.01								
<b>End thickness</b> Spessore spalla Stärke der Seitenwand Épaisseur de cheue joue Espesor lateral mm	55.00								

## Cross sections

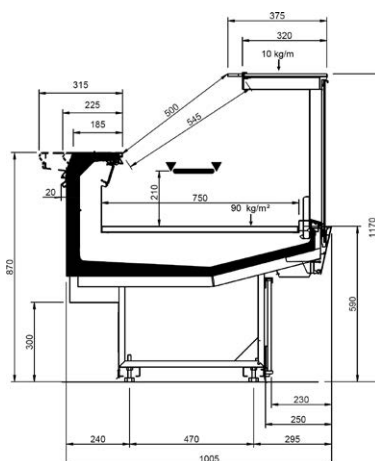

DD

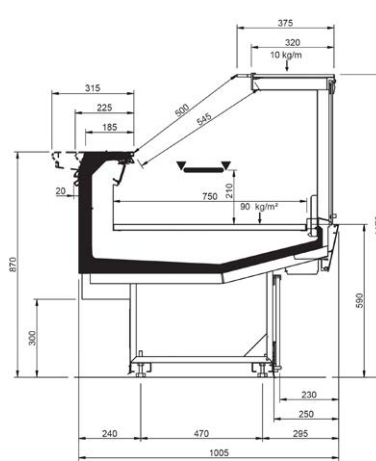

LD

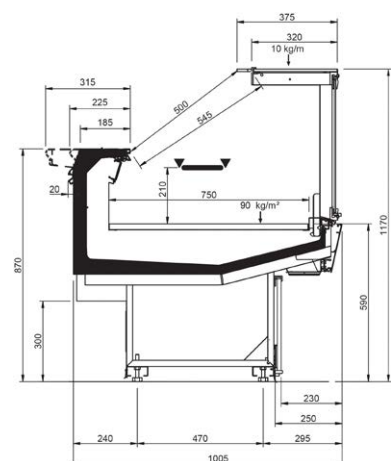

ODF

## Cross Sections

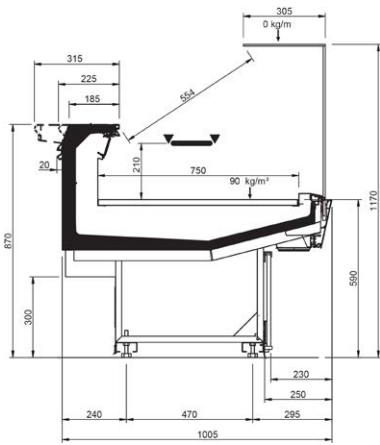

DDP

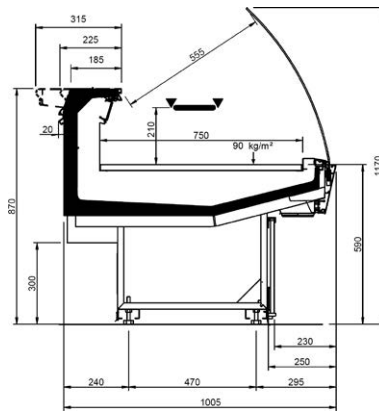

DC

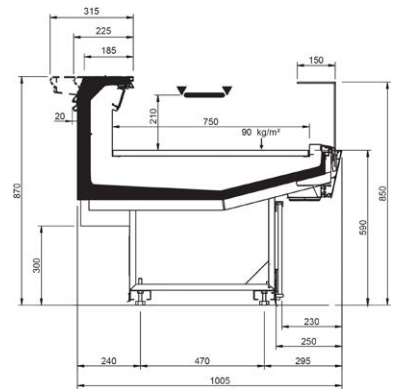

LS-P

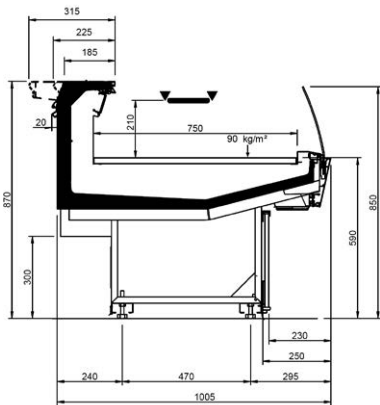

LS-C

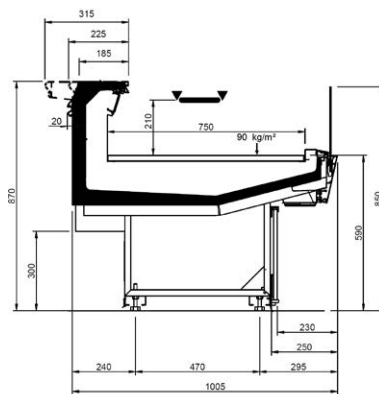

LS-D