

ECO₂ SMALL PLUS

MT from 40 to 100 [kW]

LT from 0 to 25 [kW]

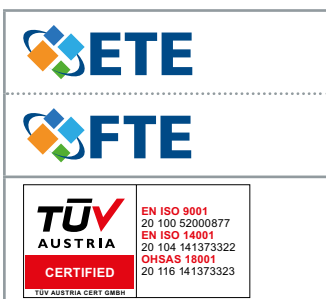

Range of Power Packs CO₂

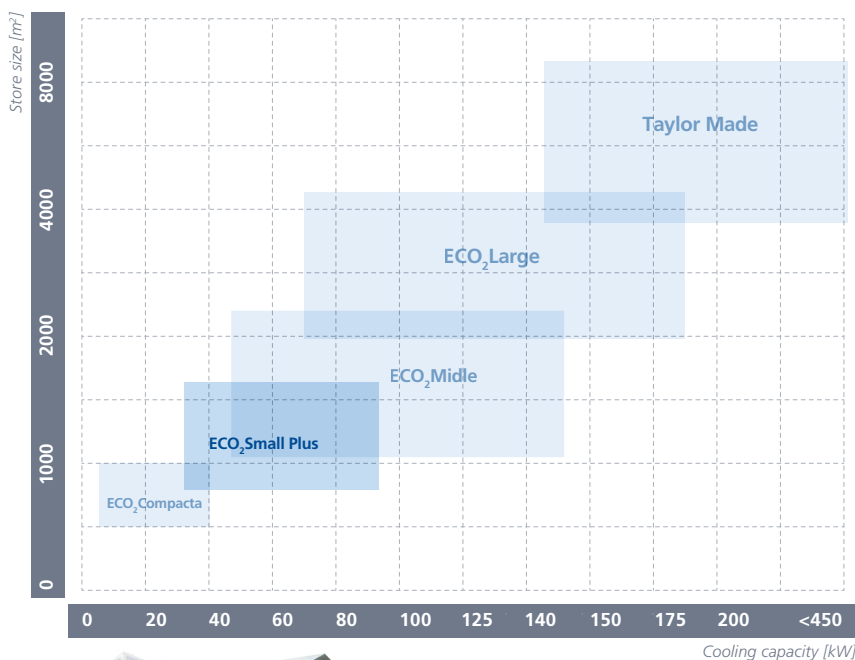

- CO₂ transcritical unit.
- Very compact product
- Modular design for manutention and complex installation.
- Booster LT and MT.
- Indoor or outdoor installation
- Low noise level.
- High pressure oil solution from EPTA.
- ETE and FTE performing systems available on this platform
- Combined onboard FTE 2.0 system available
- Easy maintenance concept

Technical Information

Compressors BITZER	MT3 + LT2
Number of MT compressor	max 3
Number of LT compressor	max 2
Number of ETE compressor	max 1 4PTE-7K/ 4MTE-10K/4KTE-12K
Smallest MT compressor	4PTE-7K
Biggest MT compressor	4DTE-25K
Smallest LT compressor	2MSL-07K / 2MME-07K
Biggest LT compressor	2FSL-4K / 2FME-4K

General	Indoor	Outdoor
Power supply	3P+T400 V (50Hz)	
Short-circuit current (kA)	35 kA (standard)	
Max weight	2570 kg	
Liquid receiver volume	110 l	
Estimated sound pressure level (max)	59 dB(A)@10m	
Sound power level (-10°C/90 bar)	86,6 dB(A)	
Installation	Indoor or outdoor version	

Pressure service	
High pressure	120 bar
Suction MT	45/53/60 bar
Suction LT	30/60 bar
Suction ETE	100 bar
Suction Liquid line	45/53/60 bar
Oil circuit	120 bar

Components and options

ACCESSORIES	BASIC	OPTIONAL
SECURITY PACK		
Double flash gas valve (1 back-up)		on request
Double transcritical valve (1 back-up)		on request
ULTRACAP or UPS integrated	•	
UPS predisposition	•	
Liquid injection MT	•	
Hot gas injection MT	•	
Hot gas injection LT	•	
Safety valve on manifold		•
Doble safety valve connected on pack	•	
Doble safety valve on remote rack		•
Alarm liquid level		•
Air desuperheater for LT outlet		•
Exchanger for back-up unit		•
Back-up R134a unit remote		•
Back-up R134a unit onboard		•
Back-up R744 unit onboard		•
MAINTENANCE PACK		
Filter suction MT	•	
Filter suction LT	•	
Filter on oil line	•	
Liquid line with dryer repacable cartridge	•	
By-pass oil separator		•
By-pass liquid line	•	
Predisposition for ICE SMART	•	
PERFORMANCE PACK		
CR II IQ module		•
Inverter MT/LT	•	
ETE integrated		•
ETE remote		•
FTE integrated		•
FTE remote		•
LSPM motor on 1st MT compressor		•

ACCESSORIES	BASIC	OPTIONAL
ELECTRICAL PANEL		
Differential protection		•
Emergency push button		•
Electrical counter		•
Display		•
Switch on pack predisposition	•	
DANFOSS regulator	•	
CAREL regulator	•	
WURM regulator		on request
MECHANICAL		
Housing		•
Noise insulation on housing.		•
Feet with absorbers feet.	•	
EXCHANGERS		
Exchanger for heat recovery onboard		•
Exchanger for heat recovery remote		•
Economizer (exchanger out GC / flash gas)		•
Auto subcooler for liquid line with regulation.		on request
Auto subcooler for liquid line (exchanger liquid line / flash gas)		on request
Subcooler outlet gas cooler exchanger		•
Gas cooler onboard		on request

Dimensions

INDOOR UNIT

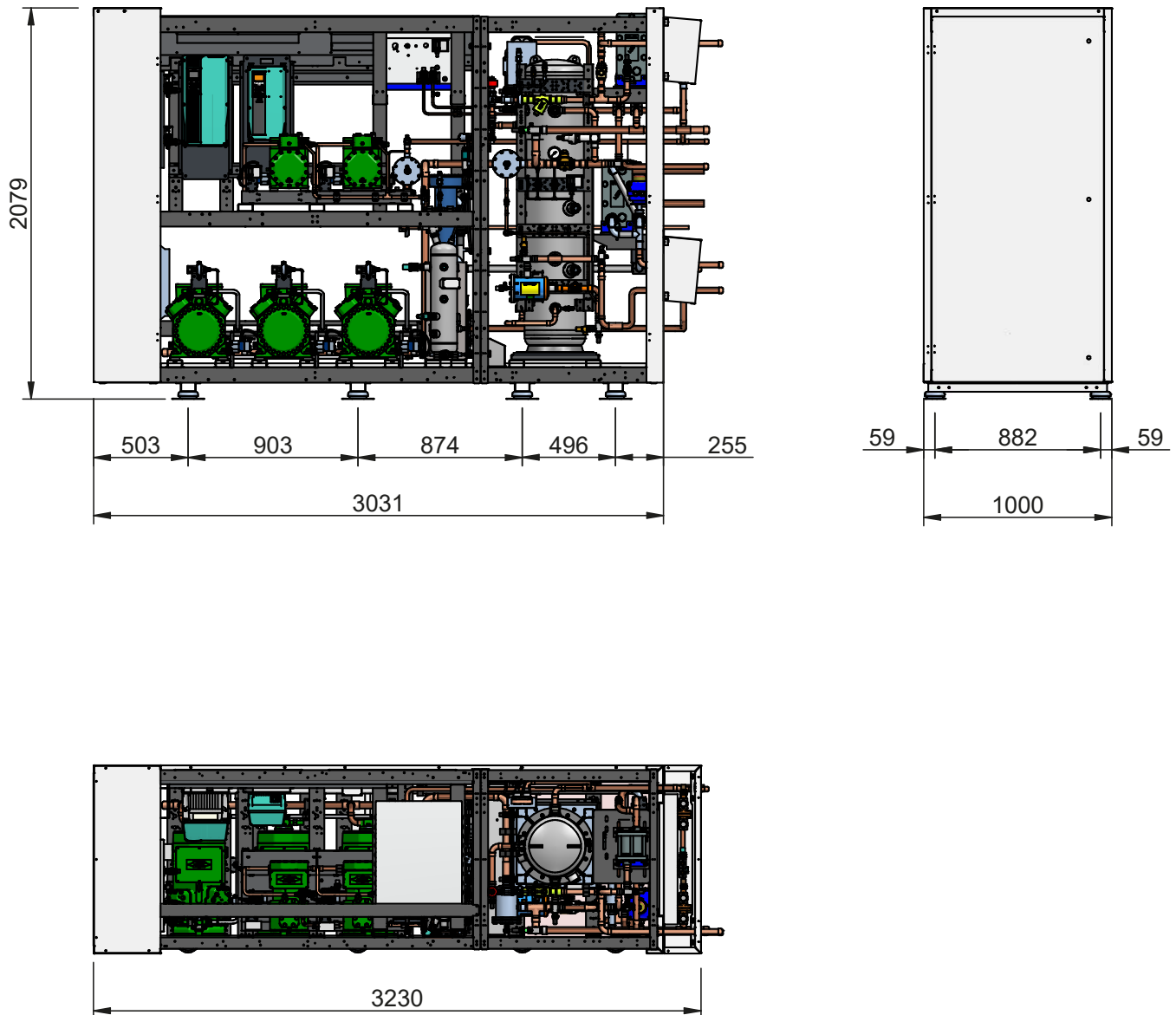

Dimensions

INDOOR UNIT: LIQUID RECEIVER REMOTE

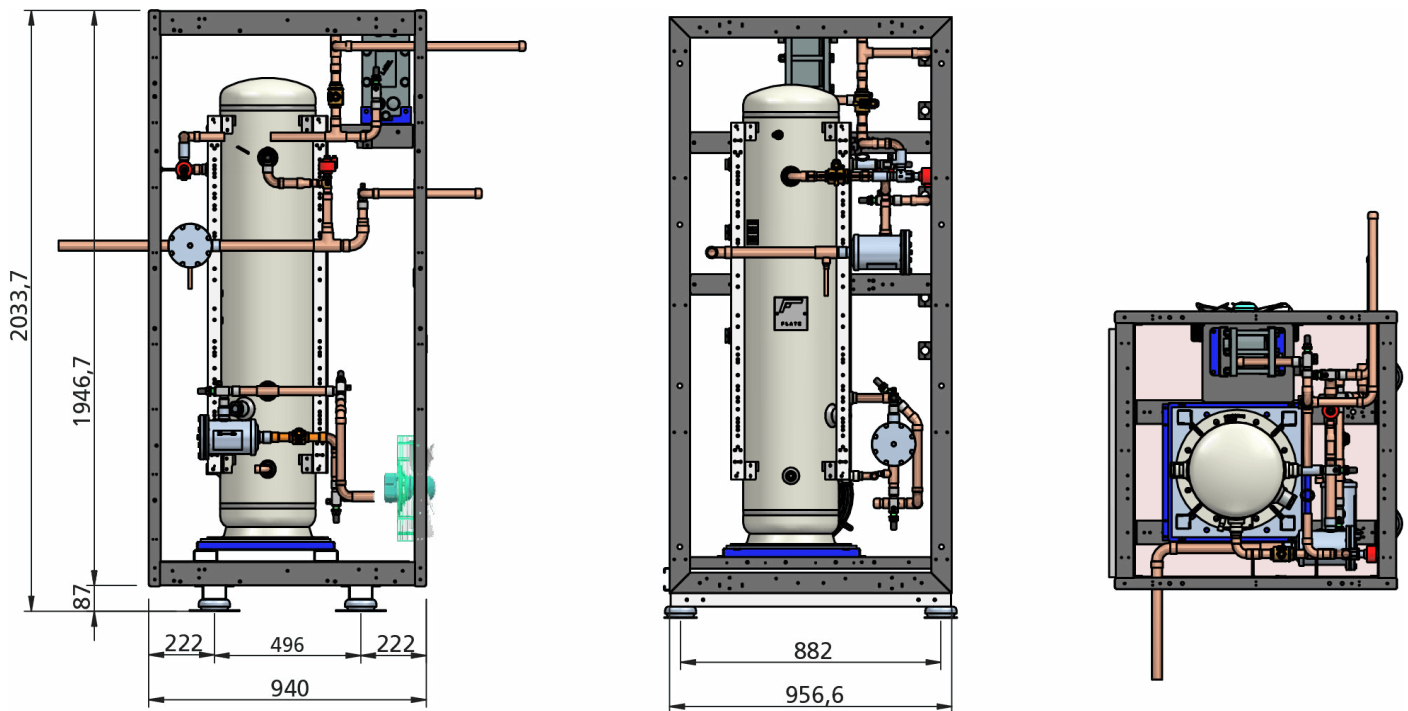

PACK MTILT WITHOUT LIQUID RECEIVER

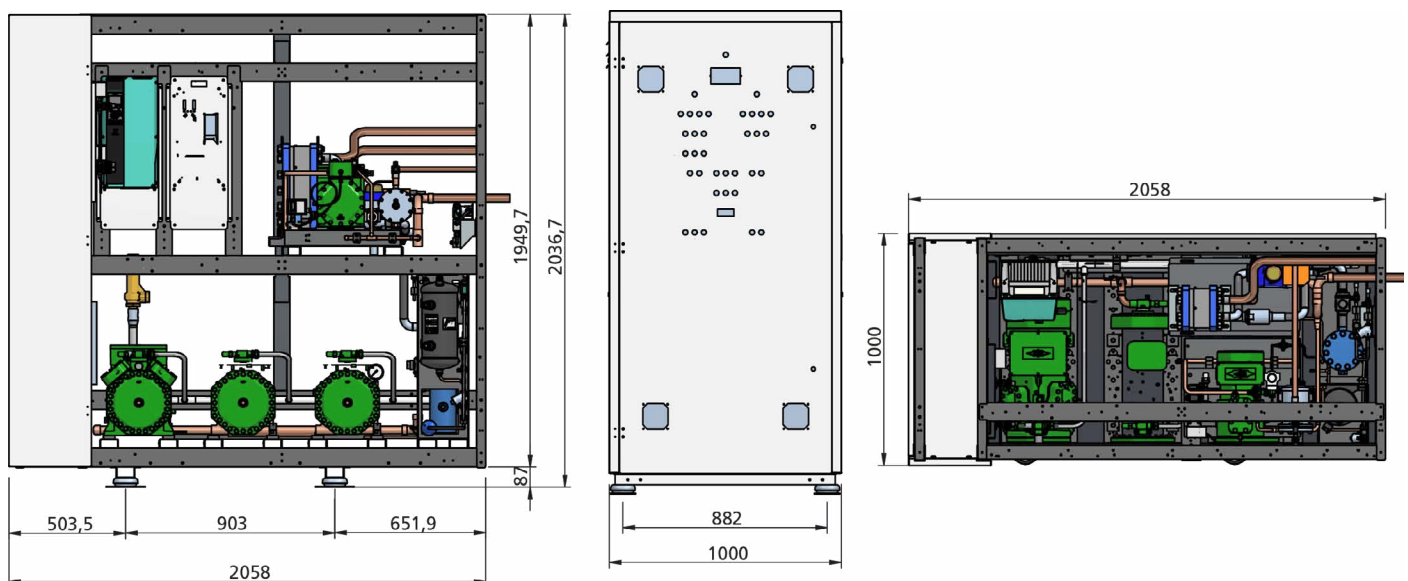

Dimensions

OUTDOOR UNIT

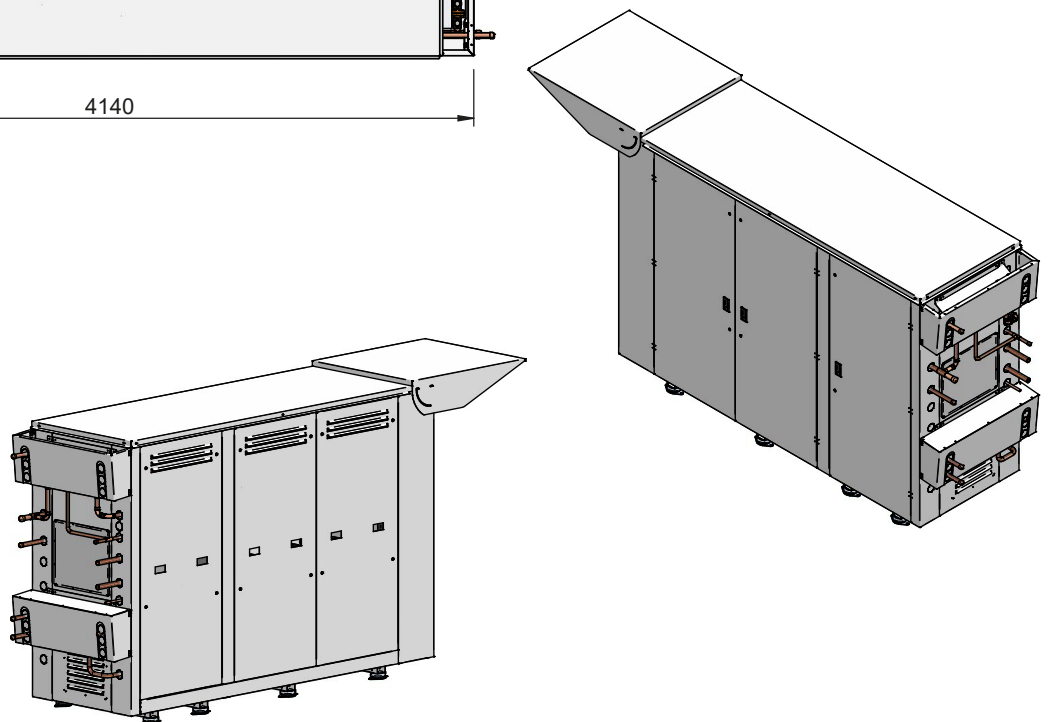
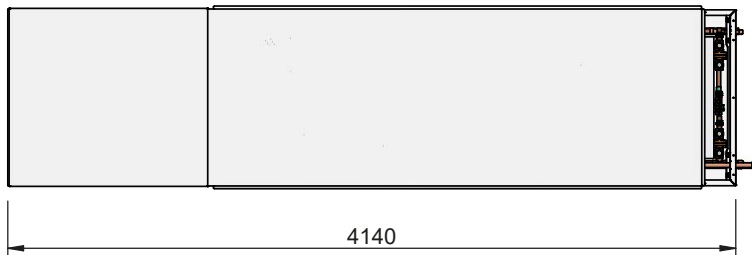
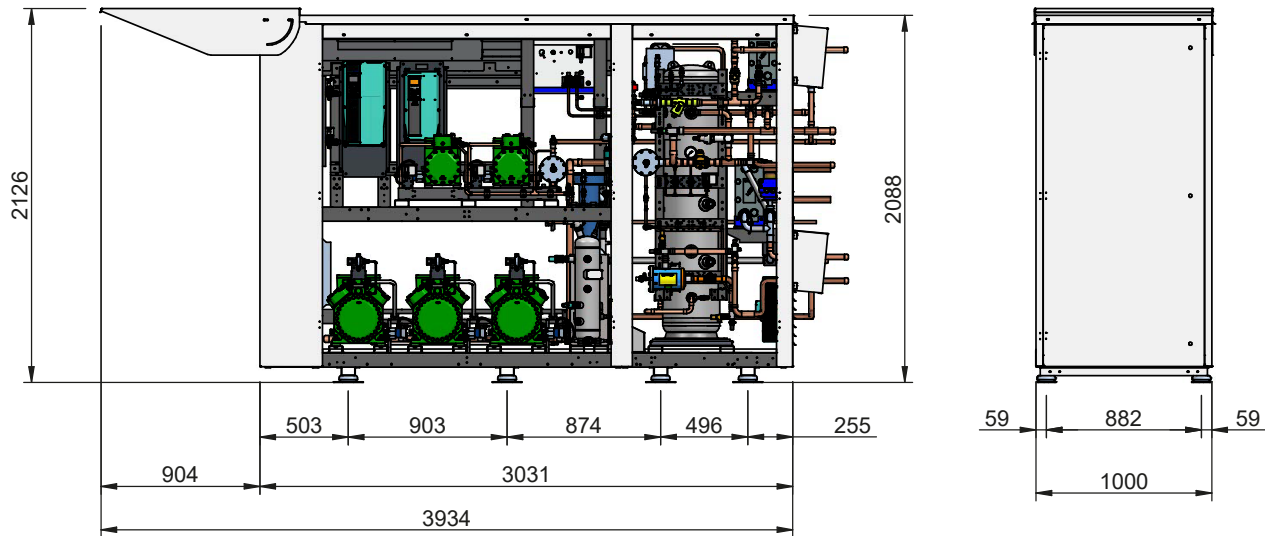

Dimensions

ECOSMALL WITH GAS COOLER ONBOARD

