

DUALIO E					
<b>Lenght</b> -Lunghezza Longueur-Länge-Longitud mm	<b>1250</b>	<b>1875</b>	<b>2500</b>	<b>3750</b>	<b>EOL 1650</b>
<b>LL-235</b>	•	•	•	•	•
<b>MAX LL-365</b>	•	•	•	•	•
<b>Dispaly area</b> Superficie di esposizione Warenpräsentationsfläche Surface d'exposition Superficie expositiva m2	1.75	2.62	3.5	5.25	1.16
<b>Loading area</b> Superficie di appoggio Nutzfläche Surface de chargement Superficie de apoyo m2	2.06	3.09	4.12	6.18	1.6
<b>End thickness</b> Spessore spalla Stärke der Seitenwand Épaisseur de cheque joue Espesor lateral mm	50.00				

DUALIO E

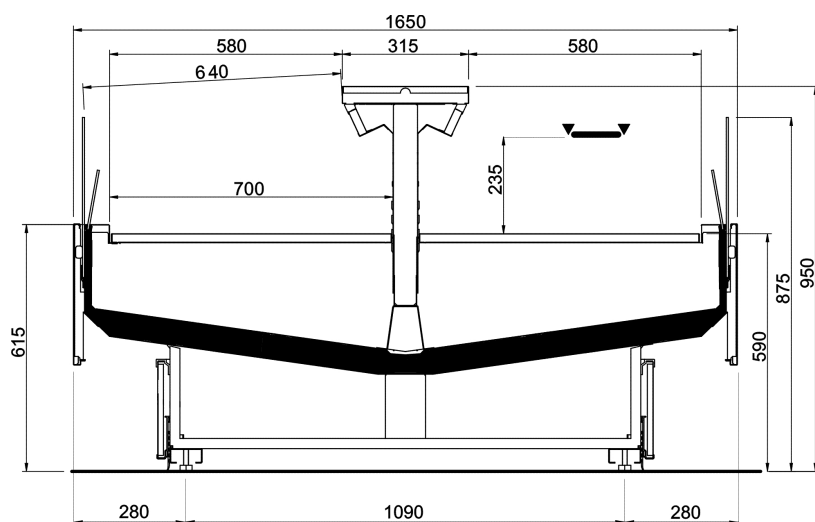

DUALIO E EOL

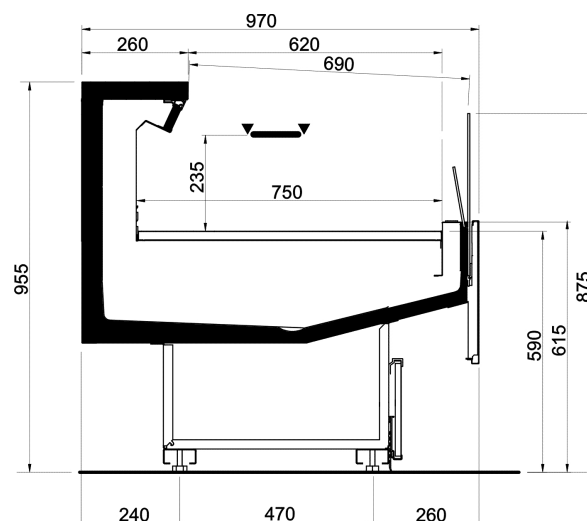

DUALIO E MAX

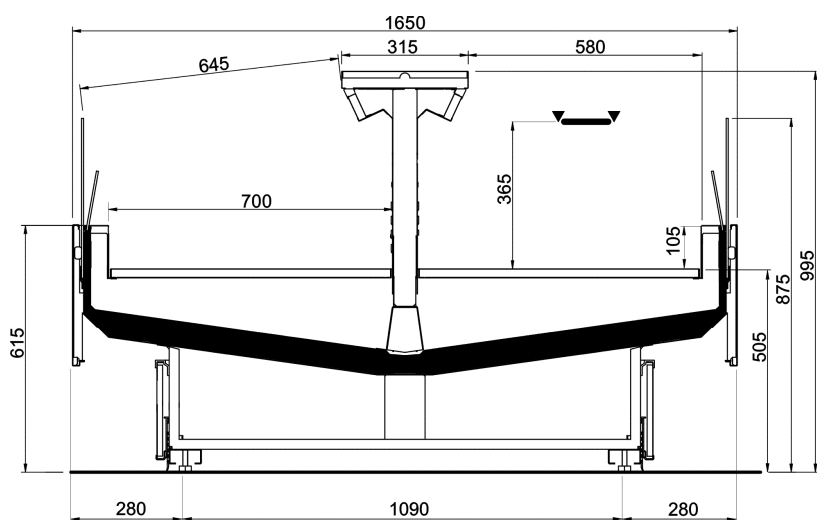

DUALIO E MAX EOL

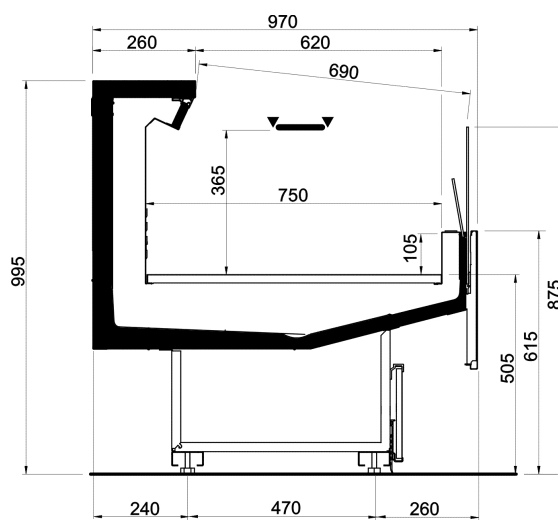

## Legend

 Meat	 Chicken	 Fish	 Pre-packed fish
 Delicatessen	 Cheese	 Dairy products	 Gastronomy
 Pastries	 Pre-packed fish	 Fruits and Vegetables	 Sandwiches
 Drinks	 Pizza	 Bread	 Frozen food and ice cream
 Off-cycle defrost	 Electric defrost	 Hot-gas defrosting system	 Manual defrost
 Ventilated	 Static	 Incorporated condensing unit	 Remote condensing unit
 Bagnomaria	 Ceramic glass	 Ice	 VSD Inverter technology
 LED lighting	 Zero C doors	 High efficiency fans	 R290 Propane refrigerant gas (R290)
 R134a - 400V/3PH/50Hz	 R404A - 400V/3PH/50Hz	 R744 - 400V/PH/50Hz	 Semi-hermetic reciprocating compressor
 Hermetic scroll compressor	 Compressor hermetic reciprocating	 External installation	 Machinery room
 Soundproof housing	 On board condenser	 Remote condenser	 DUAL Medium & Low temperature